

Stopper cylinders DFST



Stopper cylinders DFST

Key features

At a glance

- Gentle stopping without impact vibration or noise
- Single-acting or double-acting
- Powerful shock absorber for high energy absorption
- Wide range of applications thanks to adjustable shock absorber
- Supply ports at side or underneath
- Adjustable active direction thanks to rotatable toggle lever arrangement (90°, 180°, 270°)
- Position sensing via inductive proximity sensor SIEN on the toggle lever or via proximity sensor for T-slot SME-/SMT-8 on the piston
- Sturdy design for long service life
- Stable guide rod
- Seal for protection against dirt and moisture

The technology in detail

Cushioning adjustment

- Adaptable shock absorber depending on the load on the conveyed good
- Easy adjustment via knurled adjusting wheel **1**
- Shock absorber can be replaced in the fitted position



Optional: toggle lever lock

- For locking the toggle lever **1**
- The toggle lever lock **2** can be ordered as a variant of the stopper cylinder or as an accessory
- Simple design
- Reliable function

Piston Ø 50:

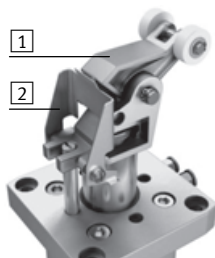

Piston Ø 63, 80:

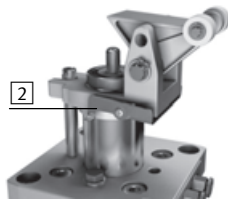

Toggle lever deactivator

- For deactivation of the stop function
- The toggle lever deactivator can be ordered as an accessory
- Simple design

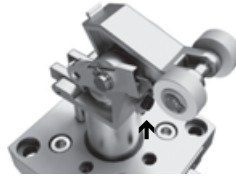

Position sensing

- Sensing of the toggle lever position (conveyed good in stop position) via inductive proximity sensor SIEN-M8 **1**
- Sensing of the piston position (cylinder retracted or advanced) via proximity sensor SME-/SMT-8 in the slot **2**

Sensing of the toggle lever position

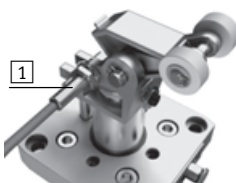

Sensing of the piston position



Stopper cylinders DFST

Key features

FESTO

Functional sequence

Step 1

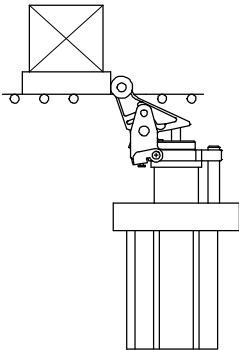

1. Gentle stopping of heavy masses via a hydraulic shock absorber in the piston rod.

Step 2

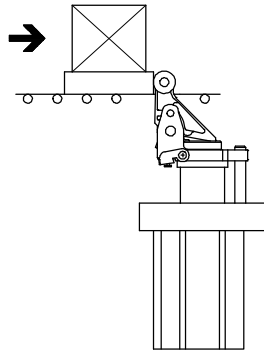

2. The toggle lever (optional) is locked into the retracted end position so that the conveyed good cannot be pushed back by the shock absorber.

Step 3

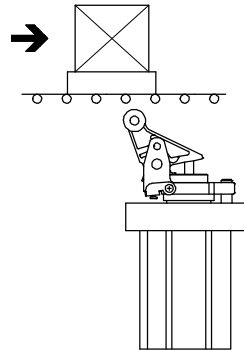

3. The conveyed good is released by means of compressed air, and the toggle lever is released simultaneously.

Step 4

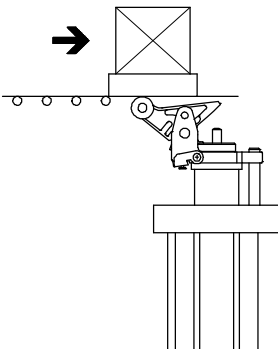

4. The piston is advanced by means of spring force or compressed air. The toggle lever tips back which prevents the conveyed good from being pushed up.

Step 5

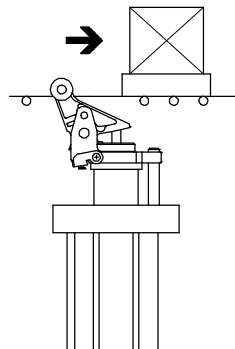

5. The toggle lever is raised by means of spring force and stops the next conveyed good.

Stopper cylinders DFST

Type codes

DFST – 50 – 30 – D L – Y4 – A

Type

DFST	Stopper cylinder
------	------------------

Piston Ø [mm]

Stroke [mm]

Function

	Single-acting, pulling
D	Double-acting

Locking

	No
L	Via toggle lever lock

Cushioning

Y4	Adjustable shock absorber
----	---------------------------

Position sensing

A	Via proximity sensor
---	----------------------

Stopper cylinders DFST

Peripherals overview

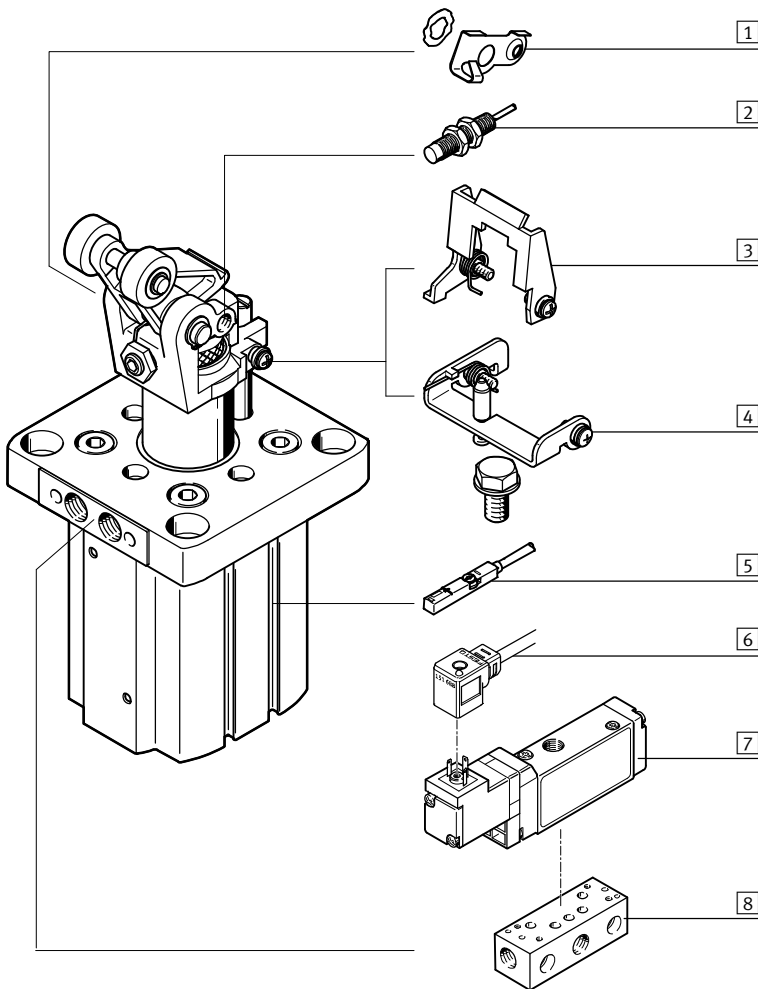



Variants and accessories		
Type	Description	→ Page/Internet
1 Toggle lever deactivator DADP-TF	For deactivation of the stop function. The conveyed good is able to pass the stopper cylinder without activating the cylinder	15
2 Proximity sensor, inductive SIEN-M8	For sensing of the toggle lever position	15
3 Toggle lever lock DADP-TL	<ul style="list-style-type: none"> For piston \varnothing 50 For locking the toggle lever in the retracted position. With pressurisation, the conveyed good and the toggle lever are released simultaneously 	15
4 Toggle lever lock DADP-TL	<ul style="list-style-type: none"> For piston \varnothing 63, 80 For locking the toggle lever in the retracted position. With pressurisation, the conveyed good and the toggle lever are released simultaneously 	15
5 Proximity sensor SME-/SMT-8	For sensing the piston position	15
6 Plug socket with cable KMEB	-	14
7 Solenoid valve MEBH	For quick and direct actuation of the stopper cylinder	14
8 Intermediate plate ZVA-2	For attaching the valve	15

Stopper cylinders DFST

Technical data

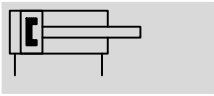
FESTO



-  Diameter
50 ... 80 mm

-  Stroke length
30 ... 40 mm



General technical data				
Piston \varnothing		50	63	80
Pneumatic connection		G1/8		
Stroke	[mm]	30		40
Constructional design		Piston rod with toggle lever		
Mode of operation		Double-acting		
		Single-acting, pulling		
Protection against torsion/guide		Guide rod		
Type of mounting		Via through-holes		
Cushioning (of piston movement)		Flexible cushioning rings/pads at both ends		
Position sensing		Via proximity sensor		
Mounting position		Vertical		
Product weight	[g]	1800	3500	6850

Operating and environmental conditions	
Operating medium	Compressed air in accordance with ISO 8573-1:2010 [7:-:-]
Operating pressure ¹⁾	[bar] 2 ... 10
Ambient temperature	[°C] 5 ... 60
Corrosion resistance class CRC ²⁾	1

1) Min. operating pressure for piston \varnothing 50 with toggle lever lock is 3 bar

2) Corrosion resistance class 1 as per Festo standard 940 070

Components requiring low corrosion resistance. Transport and storage protection. Parts that do not have primarily decorative surface requirements, e.g. in internal areas that are not visible or behind covers.

Materials

Sectional view

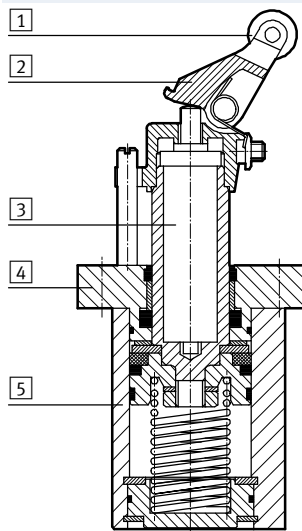

Stopper cylinder			
Piston \varnothing		50	63, 80
1	Rollers	Polyacetate	
2	Attachments	Nickel-plated cast steel	
3	Piston rod	High-alloy stainless steel	
4	End cap	Die-cast aluminium	Wrought aluminium alloy
5	Housing	Wrought aluminium alloy	
-	Seals	Nitrile rubber	
	Note on materials	RoHS-compliant	

Stopper cylinders DFST

Technical data

Braking distance

The braking distance refers to the distance from when contact is made with the toggle lever to the end stop.

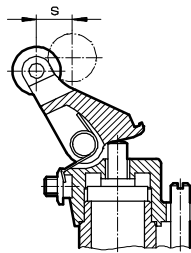

Piston \varnothing		50	63	80
Braking distance	[mm]	14.75	14.75	20

Resetting force F_R of the toggle lever against the delivery direction

The resetting force refers to the minimum force that must be applied to press the toggle lever into the end position.

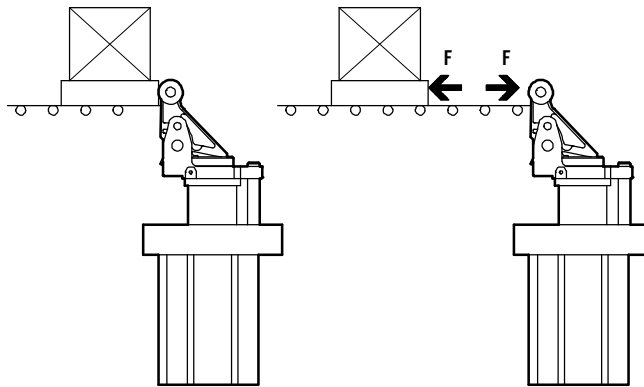

Piston \varnothing		50	63	80
Resetting force at the toggle lever	[N]	11	23	36

Permissible impact force F_{Impact} on the rollers of the toggle lever when the piston rod is advanced and the toggle lever is pushed into its end position

The permissible impact force refers to the momentary force that may act on the toggle lever when it is already pushed into its end position without damaging the rod bearing or the toggle lever mechanism.

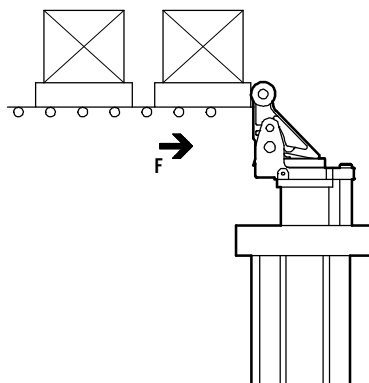

Piston \varnothing		50	63	80
Impact force	[N]	3000	5000	6000

Stopper cylinders DFST

Technical data

Permissible mass m as a function of the conveyor speed v

The values in the graph opposite take into account a friction value of $\mu = 0.1$.

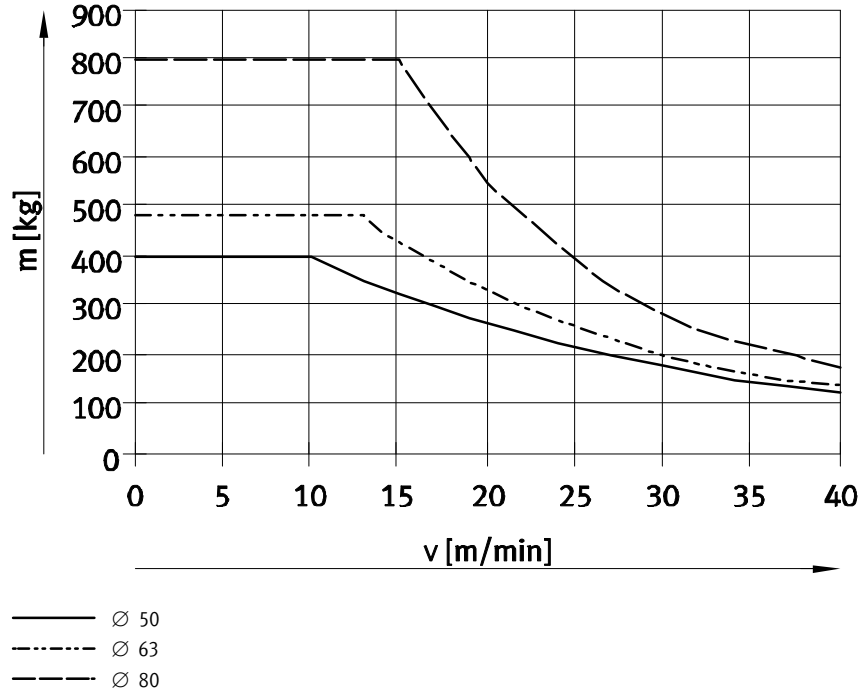

Permissible transverse force F_Q during the switching operation as a function of the pressure p

The applied load causes a transverse force to act on the piston rod. To ensure the function of the cylinder, a certain minimum pressure must be applied.

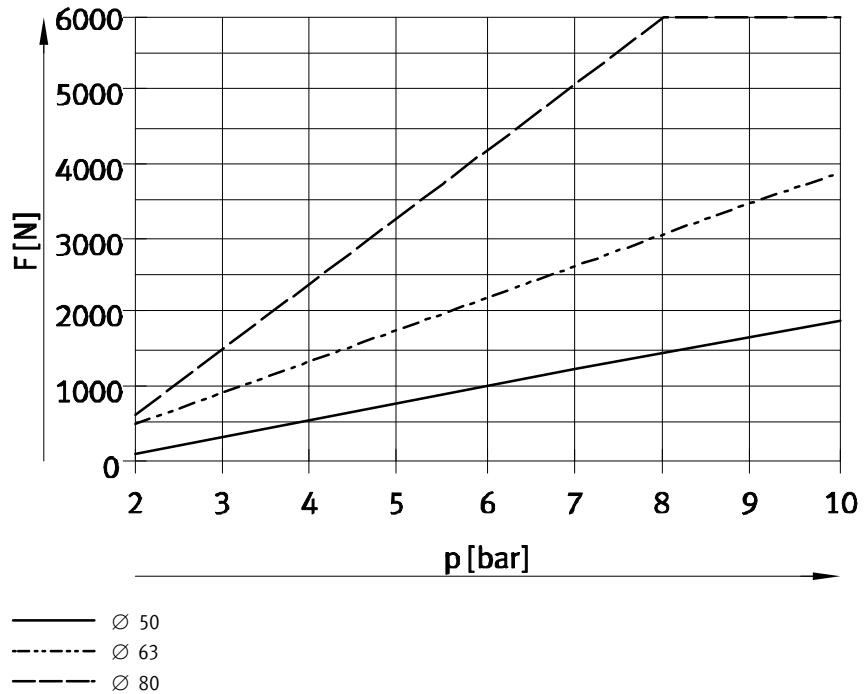

Stopper cylinders DFST

Technical data

Selection aid

Stopping a workpiece carrier

The stopper cylinder is used to brake an individual workpiece carrier, with-out or without end position locking. The toggle lever and oil damper are pushed into the end position again for each new workpiece carrier.

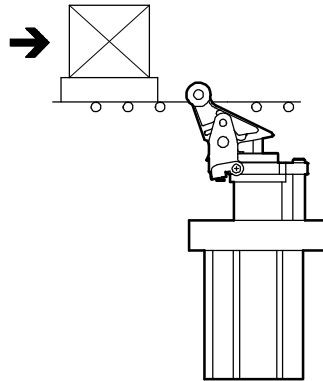

Example

Given:

Friction value $\mu = 0.1$

Delivery speed $v = 20 \text{ m/min}$

Workpiece carrier with workpiece $m = 200 \text{ kg}$

Operating pressure $p = 6 \text{ bar}$

Choice: Stopper cylinder DFST-50

1. Checking the permissible mass

The maximum permissible mass at a delivery speed of 20 m/min is 250 kg. This means that the total mass of the workpiece carrier and workpiece of 200 kg is permissible.

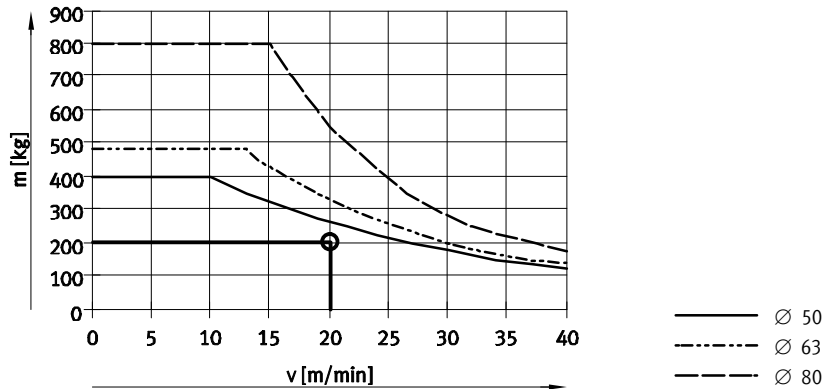

2. Checking the permissible transverse force during the switching operation

Transverse force $F_Q = \text{friction force}$

F_{Friction}

$$\begin{aligned}
 F_{\text{Friction}} &= \mu \times m \times g \\
 &= 0.1 \times 200 \text{ kg} \times 9.81 \text{ m/s}^2 \\
 &= \text{approx. } 200 \text{ N}
 \end{aligned}$$

The maximum permissible transverse force at an operating pressure of 6 bar is 1000 N.

This means that the transverse force of 200 N is permissible.

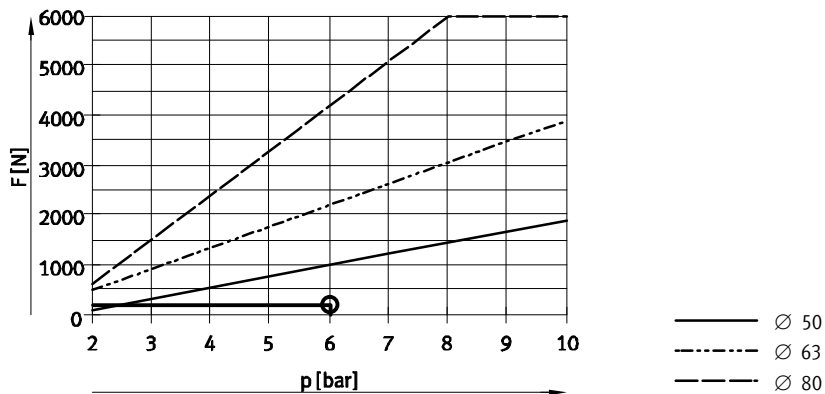

Stopper cylinders DFST

Technical data

Selection aid

Stopping or separating several workpiece carriers

The stopper cylinder is used to separate workpiece carriers. Further workpiece carriers accumulate behind carriers that have already pushed the toggle lever into its end position. Since the oil damper in the stopper cylinder is inoperative in this case, a certain amount of cushioning between the workpiece carriers must be guaranteed (e.g. elastomer elements).

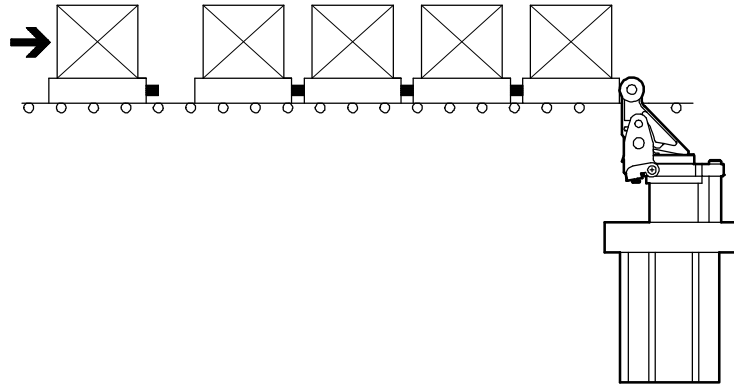

Example

Given:

Friction value $\mu = 0.1$

Delivery speed $v = 15 \text{ m/min}$

Workpiece carrier with workpiece $m = 100 \text{ kg}$

Operating pressure $p = 6 \text{ bar}$

Maximum number of workpiece carriers accumulating simultaneously $n_{\text{Group}} = 1$

Maximum number of all queued workpiece carriers $n_{\text{Queue}} = 5$

Maximum number of all advancing workpiece carriers $n_{\text{Queue-1}} = 4$

Spring travel of the workpiece carrier buffer $s_F = 10 \text{ mm}$

Choice: Stopper cylinder DFST-50

1. Checking the permissible mass of the first workpiece carrier

The maximum permissible mass at a delivery speed of 15 m/min is 320 kg. This means that the total mass of the workpiece carrier and workpiece of 100 kg is permissible.

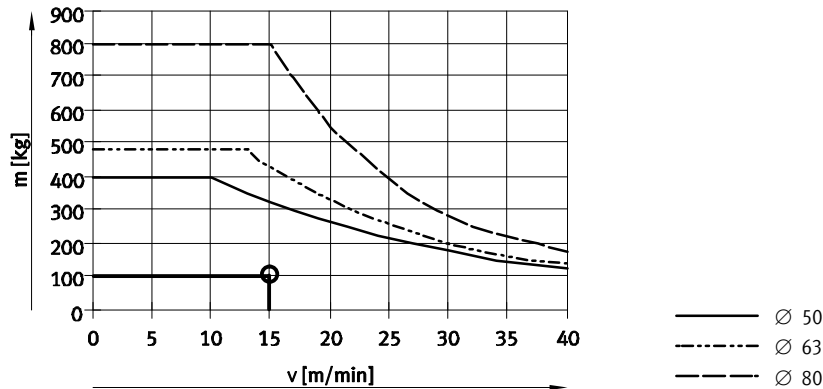

2a. Calculation of the maximum permissible impact force when workpiece carriers accumulate behind a carrier at the stopper cylinder

With the DFST-50, the maximum permissible impact force is 3000 N. This means that at a total force of 1,150 N, the number of workpiece carriers is permissible.

Impact force calculation:

$$F_{\text{Impact}} = \frac{(n_{\text{Group}} \times m) \times v^2}{s_F} = \frac{(1 \times 100\text{kg}) \times (15\text{m}/60\text{s})^2}{0.01\text{m}} = \text{ca.}650\text{N}$$

Friction force:

$$F_{\text{Friction}} = \mu \times (n_{\text{Queue}} \times m) \times g = 0.1 \times (5 \times 100\text{kg}) \times 9.81\text{m}/\text{s}^2 = \text{ca.}500\text{N}$$

Max. total force:

$$F_{\text{Total force}} = F_{\text{Impact}} + F_{\text{Friction}} = 650\text{N} + 500\text{N} = 1150\text{N}$$

Stopper cylinders DFST

Technical data

Selection aid

2b. Checking the permissible transverse force during the switching operation

Transverse force $F_Q =$
friction force F_{Friction}
 $F_{\text{Friction}} = 500 \text{ N}$

The maximum permissible transverse force at an operating pressure of 6 bar is 1000 N.
This means that the transverse force of 500 N is permissible.

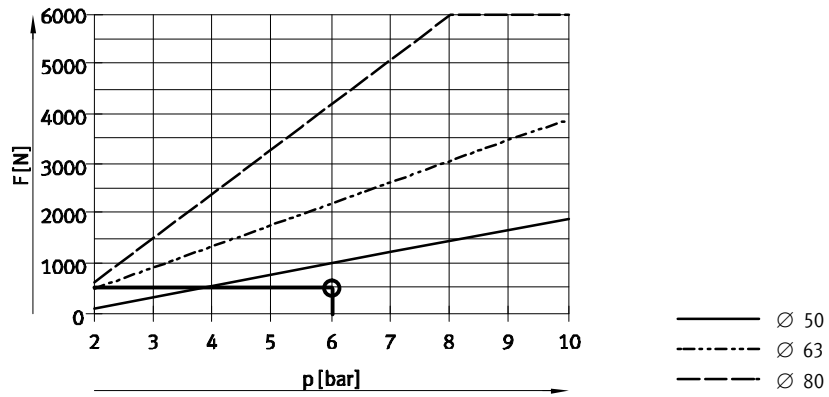

3. Separating and advancing the workpiece carriers

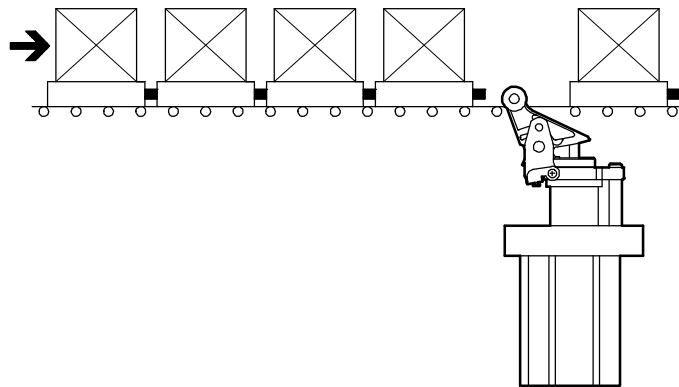

The maximum permissible mass with the DFST-50 at a delivery speed of 15 m/min is 320 kg.
Since the total mass of the four workpiece carriers advancing on the stopper cylinder is 400 kg, the next largest stopper cylinder must be selected for separating.

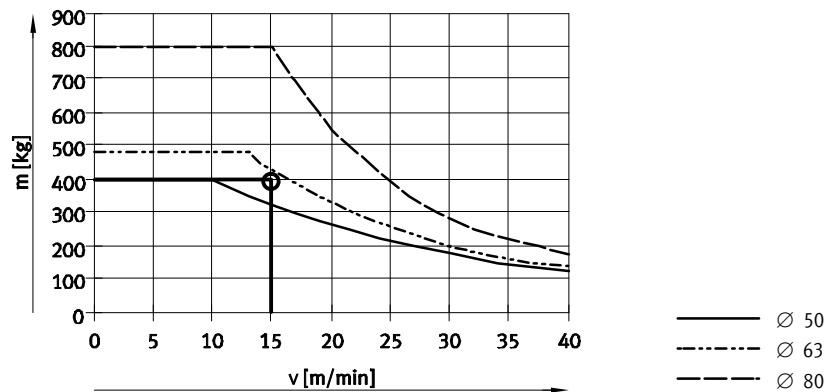

Max. total mass:

$$m_{\text{Total force}} = n_{\text{Queue}-1} \times m = 4 \times 100\text{kg} = 400\text{kg}$$

Result

The stopper cylinder DFST-63 must be selected for separating five workpiece carriers.

Stopper cylinders DFST

Technical data

FESTO

Dimensions

Download CAD data → www.festo.com

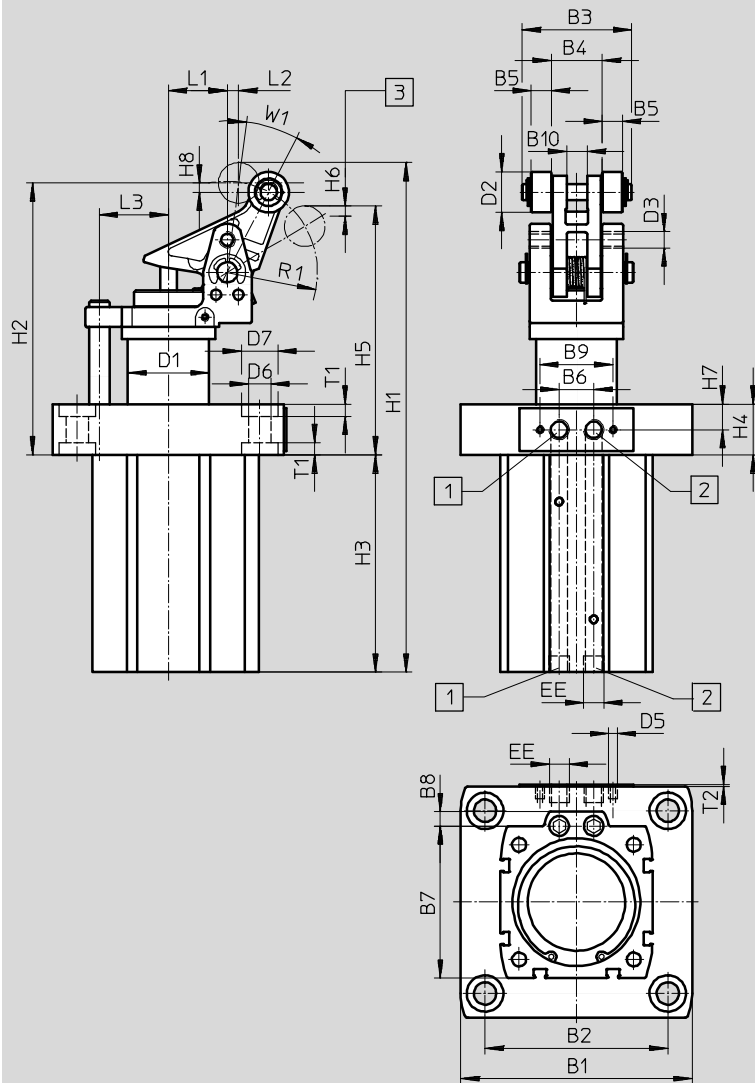

- 1 Supply port (retract)
- 2 Supply port (advance)
- 3 Maximum permissible underside depth of workpiece carrier

∅	B1	B2	B3	B4	B5	B6	B7	B8	B9	B10	D1	D2	D3	D5	D6
[mm]	□	□					□				∅	∅			∅
50	93	73	43	20	8		64			8.1	32	20	M8x1	M4	9
63	114	90	54	25	10	17	75	7	36	10.1	40	20			11
80	138	110	63	30	12		95			12.1	50	25			13

∅	D7	EE	H1	H2	H3	H4	H5	H6	H7	H8	L1	L2	L3	R1	T1	T2	W1
[mm]	∅																
50	14	G1/8	219	118	91	17.5	107.5	5	8.75	5.5	14	5	26	36.3	5	1	25
63	18		251	134	107	25	123	5	12.5	4.5	29	6	34	44.4	6	-	20
80	20		322.5	159	151	19	144	4.2	9.5	6.8	36	8	42	55.5	6	-	22

Stopper cylinders DFST

Technical data

FESTO

Ordering data						
	Piston \varnothing	with spring	without spring	with toggle lever lock	Part No.	Type
	50	■			543 729	DFST-50-30-Y4-A
		■		■	555 572	DFST-50-30-L-Y4-A
			■		543 730	DFST-50-30-D-Y4-A
			■	■	555 573	DFST-50-30-DL-Y4-A
	63	■			543 744	DFST-63-30-Y4-A
		■		■	555 574	DFST-63-30-L-Y4-A
			■		543 745	DFST-63-30-D-Y4-A
			■	■	555 575	DFST-63-30-DL-Y4-A
	80	■			543 747	DFST-80-40-Y4-A
		■		■	555 576	DFST-80-40-L-Y4-A
			■		543 748	DFST-80-40-D-Y4-A
			■	■	555 577	DFST-80-40-DL-Y4-A

Stopper cylinders DFST

Accessories



Mounting options for solenoid valves and valve functions

A solenoid valve MEH, MEBH, MOEH or MOEBH can be mounted on the stopper cylinder for quick, direct

actuation of the cylinder. The valve must be connected to the cylinder via an intermediate plate ZVA. The posi-

tion of the piston rod when the solenoid valve is in the normal position

depends on the valve type and the position of the valve on the cylinder.

Ordering data – Solenoid valve Technical data → Internet: meh

Mounting options for the solenoid valve with intermediate plate ZVA	Position of the piston rod in normal position	Part No.	Type
Single-acting			
		173125	MEH-3/2-5,0-B
		172999	MEBH-3/2-5,0-B
		173429	MOEH-3/2-5,0-B
		173002	MOEBH-3/2-5,0-B
Double-acting			
		173128	MEH-5/2-5,0-B
		173005	MEBH-5/2-5,0-B
		173128	MEH-5/2-5,0-B
		173005	MEBH-5/2-5,0-B

Ordering data – Plug socket with cable Technical data → Internet: kmeb



	For Ø	Part No.	Type
	50, 63, 80	151688	KMEB-1-24-2,5-LED
		151689	KMEB-1-24-5-LED
		193457	KMEB-1-24-10-LED

Stopper cylinders DFST

Accessories

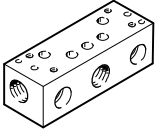
FESTO

Ordering data – Intermediate plate			
	For Ø	Part No.	Type
	50, 63, 80	164897	ZVA-2

Ordering data			
	For Ø	Part No.	Type
Lever locking mechanism DADP-TL			
	50	543751	DADP-TL-F3-50
	63	543752	DADP-TL-F3-63
	80	543753	DADP-TL-F3-80
Free pass mechanism DADP-TF			
	50	543755	DADP-TF-F3-50
	63	543756	DADP-TF-F3-63
	80	543757	DADP-TF-F3-80

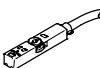
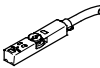

Ordering data – Proximity sensor, inductive				Technical data → Internet: sien	
	For Ø	Contact	Electrical connection	Part No.	Type
	50, 63, 80	N/O contact	Cable, 2.5 m	150386	SIEN-M8B-PS-K-L
			Plug	150387	SIEN-M8B-PS-S-L
		N/C contact	Cable, 2.5 m	150390	SIEN-M8B-PO-K-L
			Plug	150391	SIEN-M8B-PO-S-L



Ordering data – Proximity sensors for T-slot, magneto-resistive					Technical data → Internet: smt	
	Type of mounting	Switch output	Electrical connection	Cable length [m]	Part No.	Type
N/O contact						
	Insertable in the slot from above, flush with cylinder profile, short design	PNP	Cable, 3-wire	2.5	574335	SMT-8M-A-PS-24V-E-2,5-OE
			Plug M8x1, 3-pin	0.3	574334	SMT-8M-A-PS-24V-E-0,3-M8D
			Plug M12x1, 3-pin	0.3	574337	SMT-8M-A-PS-24V-E-0,3-M12
		NPN	Cable, 3-wire	2.5	574338	SMT-8M-A-NS-24V-E-2,5-OE
			Plug M8x1, 3-pin	0.3	574339	SMT-8M-A-NS-24V-E-0,3-M8D
N/C contact						
	Insertable in the slot from above, flush with cylinder profile, short design	PNP	Cable, 3-wire	7.5	574340	SMT-8M-A-PO-24V-E-7,5-OE

Stopper cylinders DFST

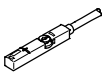
Accessories

FESTO

Ordering data – Proximity sensor for T-slot, magnetic reed					Technical data → Internet: sme	
	Type of mounting	Switching output	Electrical connection	Cable length [m]	Part No.	Type
N/O contact						
	Insertable in slot from above, flush with cylinder profile	Contacting	Cable, 3-wire	2.5	543862	SME-8M-DS-24V-K-2,5-OE
				5.0	543863	SME-8M-DS-24V-K-5,0-OE
			Cable, 2-wire	2.5	543872	SME-8M-ZS-24V-K-2,5-OE
			Plug M8x1, 3-pin	0.3	543861	SME-8M-DS-24V-K-0,3-M8D
	Insertable in slot lengthwise, flush with cylinder profile	Contacting	Cable, 3-wire	2.5	150855	SME-8-K-LED-24
			Plug M8x1, 3-pin	0.3	150857	SME-8-S-LED-24
N/C contact						
	Insertable in slot lengthwise, flush with cylinder profile	Contacting	Cable, 3-wire	7.5	160251	SME-8-O-K-LED-24

Ordering data – Connecting cables				Technical data → Internet: nebu	
	Electrical connection, left	Electrical connection, right	Cable length [m]	Part No.	Type
	Straight socket, M8x1, 3-pin	Cable, open end, 3-wire	2.5	541333	NEBU-M8G3-K-2.5-LE3
			5	541334	NEBU-M8G3-K-5-LE3
	Angled socket, M8x1, 3-pin	Cable, open end, 3-wire	2.5	541338	NEBU-M8W3-K-2.5-LE3
			5	541341	NEBU-M8W3-K-5-LE3

Festo - Your Partner in Automation



1 Festo Inc.
5300 Explorer Drive
Mississauga, ON L4W 5G4
Canada

Festo Customer Interaction Center
Tel: 1 877 463 3786
Fax: 1 877 393 3786
Email: customer.service.ca@festo.com



2 Festo Pneumatic
Av. Ceylán 3,
Col. Tequesquináhuac
54020 Tlalneantla,
Estado de México

Multinational Contact Center
01 800 337 8669
ventas.mexico@festo.com



3 Festo Corporation
1377 Motor Parkway
Suite 310
Islandia, NY 11749

Festo Customer Interaction Center
1 800 993 3786
1 800 963 3786
customer.service.us@festo.com



4 Regional Service Center
7777 Columbia Road
Mason, OH 45040

Connect with us



www.festo.com/socialmedia



www.festo.com

Subject to change