



Inline flowmeter or Inline batch controller, with paddle wheel

- Up to PN 16, measurement tube size DN 06 to DN 65
- Display for indication of flow rate and volume with two totalizers or dosing
- Automatic calibration via Teach-in
- Inputs (with batch controller) and all outputs can be checked without the need for actual flow
- Total and day counters for batch quantity and number of dosing, volume or mass counter indicator (with batch controller)

Product variants described in the data sheet may differ from the product presentation and description.

Can be combined with

	Type 8611 eCONTROL – Universal controller	▶
	Type 8619 multiCELL – multi-channel/ multi-function transmitter/ controller	▶
	Type 8802 Continuous control valve systems ELEMENT – over- view	▶
	Type 8644 AirLINE SP electropneumatic automation system	▶

Type description

Device Type 8035 with paddle wheel is specially designed for use in neutral or mildly aggressive, particle-free liquids. The device is available as a flowmeter or batch controller.

The device consists of a compact Inline sensor-fitting with paddle wheel (Type S030) and a transmitter with display (Type SE35). Assembly is quick and simple thanks to a mounting/bayonet catch system. Bürkert’s “Inline Quarter-Turn” technology guarantees leak-free operation.

Bürkert’s proprietary sensor-fitting system ensures simple installation of the devices into all pipelines from DN 06 to DN 65.

The flowmeter is available as a variant with either a standard signal output or as battery-operated display/totaliser with no output.

DTS 1000011089 EN Version: X Status: RL (released | freigegeben | valide) printed: 24.03.2026

Table of contents

1. General technical data	4
1.1. About the device.....	4
1.2. All variants.....	4
1.3. Flowmeter	6
1.4. Batch controller.....	7
2. Product variants	8
2.1. Flowmeter	8
2.2. Batch controller.....	9
3. Approvals and conformities	9
3.1. General notes	9
3.2. Conformity	9
3.3. Standards.....	9
3.4. Pressure Equipment Directive (PED)	10
Device used in a pipe	10
3.5. North America (USA/Canada)	10
4. Materials	10
4.1. Bürkert resistApp.....	10
4.2. Material specifications	11
Flowmeter	11
Batch controller.....	12
5. Dimensions	13
5.1. Transmitter Type SE35	13
With cable plug (DIN EN 175301-803).....	13
With M20 × 1.5 cable glands	13
Battery-powered indicator/totalizer	14
5.2. Transmitter Type SE35 mounted in an Inline sensor-fitting Type S030.....	14
6. Performance specifications	15
6.1. Pressure temperature diagram	15
7. Product installation	15
7.1. Installation notes	15
Flow measurement.....	15
8. Product operation	16
8.1. Measurement principle	16
Flowmeter:	16
Batch controller:	16
8.2. Functional overview	17
Display and operating keys.....	17
Operating levels	18
8.3. Function modes	20
Flowmeter with standardized output signal	20
Batch controller.....	20
9. Product design and assembly	21
9.1. Product assembly	21
10. Networking and combination with other Bürkert products	21

10.1. Flowmeter with a standard output signal..... 21
10.2. Batch controller..... 22

11. Ordering information **22**

11.1. Bürkert eShop 22
11.2. Recommendation regarding product selection..... 22
11.3. Bürkert Produktfilter 22
11.4. Ordering chart 23
 Flowmeter 23
 Batch controller 23
11.5. Ordering chart accessories..... 23

DTS 1000011089 EN Version: X Status: RL (released | freigegeben | valide) printed: 24.03.2026

1. General technical data

1.1. About the device

The Inline device Type 8035 is available as a flowmeter or a batch controller in a compact variant. Furthermore, the flowmeter is available either as a measuring device with a standard output signal or as a battery-powered indicator/totalizer without output.

1.2. All variants

The following data are valid for both the flowmeter and the batch controller.

Product properties

Material

Make sure the device materials are compatible with the fluid you are using.

Further information can be found in chapter [“4.1. Bürkert resistApp” on page 10.](#)

Further information on the materials can be found in chapter [“4.2. Material specifications” on page 11.](#)

Non-wetted parts

Lid	PC
Front panel film	Polyester
Cover	PC
Housing	PC
Screw	Stainless steel
Bayonet system	PC
Cable gland	PA

Wetted parts

Sensor armature	Brass, stainless steel, PVC, PP or PVDF (depending on the Inline sensor-fitting variant Type S030)
Axis and bearing	Ceramics (Al ₂ O ₃)
Paddle wheel	PVDF
Sensor-fitting body	Brass, stainless steel, PVC, PP or PVDF (depending on the Inline sensor-fitting variant Type S030)
Seal	FKM or EPDM (depending on the Inline sensor-fitting variant Type S030)
Display	15 × 60 mm, 8-digit LCD, alphanumeric, 15 segments, 9 mm high
Compatibility	Any pipe from DN 06...DN 65 which are fitted with Bürkert Type S030 Inline sensor-fitting. For the selection of the nominal diameter of the Inline sensor-fittings, see data sheet Type S030 ►.
Pipe diameter	DN 06...DN 65
Dimensions	Further information can be found in chapter “5. Dimensions” on page 13.
Measurement principle	Paddle wheel
Measuring range	<ul style="list-style-type: none"> Flow rate: 0.5...1000 l/min (0.13...265 gpm) Flow velocity: 0.3...10 m/s

Performance data

Measurement deviation	<ul style="list-style-type: none"> Teach-in: ± 1 % of the measured value¹⁾ at teach-in flow rate value Standard K-factor: ± 2.5 % of the measured value¹⁾
Linearity	± 0.5 % of full scale ¹⁾
Repeatability	± 0.4 % of the measured value ¹⁾

Electrical data

Power source (not supplied)	Limited power source according to UL/EN 62368-1 standards or limited energy circuit according to UL/EN 61010-1 paragraph 9.4
DC reverse polarity protection	Yes
Overvoltage protection	Yes
Voltage supply cable	<ul style="list-style-type: none"> Cable with maximum operating temperature greater than 80 °C (176 °F) (90 °C (194 °F) for UL-Recognized variant) Max. 50 m length, shielded

Medium data

Fluid temperature	With Inline sensor-fitting Type S030 in: <ul style="list-style-type: none"> • PVC: 0...+ 50 °C (+ 32...+ 122 °F) • PP: 0...+ 80 °C (+ 32...+ 176 °F) • PVDF, stainless steel or brass: - 15...+ 100 °C (+ 5...+ 212 °F) See data sheet Type S030 ▶ for more information.
Fluid pressure	With Inline sensor-fitting Type S030 in: <ul style="list-style-type: none"> • plastic: max. PN 10 • metal: max. PN 16 (PN 40 on request) See data sheet Type S030 ▶ for more information.
Viscosity	Max. 300 cSt
Rate of solid particles	Max. 1%
Maximum particle size	0.5 mm

Product connections

Pipe connection	With Inline sensor-fitting Type S030 in: <ul style="list-style-type: none"> • Plastic: true union with nut and solvent/fusion socket, spigot or external thread • Metal: internal or external thread, weld ends, clamp or flange See data sheet Type S030 ▶ for more information.
-----------------	--

Approvals and conformities

Directives

CE directive	Further information on the CE Directive can be found in chapter "3.3. Standards" on page 9.
Pressure equipment directive	Complying with article 4, paragraph 1 of 2014/68/EU directive Further information on the pressure equipment directive can be found in chapter "3.4. Pressure Equipment Directive (PED)" on page 10.
North America (USA/Canada)	UL Recognized for the USA and Canada

Environment and installation

Relative air humidity	≤ 80 %, without condensation
Height above sea level	Max. 2000 m
Operating condition	Continuous
Equipment mobility	Fixed
Application range	Indoor and outdoor Protect the device against electromagnetic interference, ultraviolet rays and, when installed outdoors, against the effects of climatic conditions.
Degree of protection ^{2.)} according to IEC/EN 60529	IP65 with the following conditions met: <ul style="list-style-type: none"> • device wired • cover and lid screwed tight • female cable plug or glands mounted and tightened • with blind plug on unused cable glands
Installation category	Category I according to UL/EN 61010-1
Pollution degree	Degree 2 according to UL/EN 61010-1

1.) Under reference conditions i.e. measurement medium = water, ambient and water temperature = + 20 °C (+ 68 °F), observing the minimum inlet and outlet sections and the appropriate inner diameter of the pipe.

2.) Not evaluated by UL

1.3. Flowmeter

Note:

If the device is mounted in a humid environment or outside, then the maximum voltage allowed is **35 V DC** instead of 36 V DC.

Product properties	
Material	
Female cable plug/male fixed plug	<ul style="list-style-type: none"> • Body, contact holder and cable gland in PA • Cable gland seal and flat seal in NBR
Performance data	
4...20 mA output uncertainty	± 1% of current range
Electrical data	
Operating voltage (V+)	<p>Measuring device with standard output signal</p> <ul style="list-style-type: none"> • 12...36 V DC ± 10%, filtered and regulated Connection to main supply: permanent, through external SELV (Safety Extra Low Voltage) and LPS (Limited Power Source) power supply • 115/230 V AC, 50/60 Hz Voltage supply available inside the device: <ul style="list-style-type: none"> - supplied voltage: 27 V DC regulated - maximum current: 125 mA - integrated protection: 125 mA time delay fuse <p>Battery-powered indicator/totalizer</p> <ul style="list-style-type: none"> • 4 × 1.5 V DC non-rechargeable alkaline AA batteries, lifetime 4 years at 20 °C (68 °F)
Current consumption	<p>12...36 V DC powered measuring device with standard output signal, with sensor and without pulse output consumption</p> <ul style="list-style-type: none"> • With relays: ≤ 70 mA • Without relay: ≤ 25 mA
Power consumption	115/230 V AC powered measuring device: 3 VA
Output	<p>Measuring device with standard output signal</p> <ul style="list-style-type: none"> • Transistor (pulse): <ul style="list-style-type: none"> - potential free - NPN or PNP (wiring dependant) - function: pulse output, adjustable pulse value - 0...400 Hz - 5...36 V DC, 100 mA, voltage drop at 100 mA: 2.5 V DC - duty cycle (pulse duration/period): 0.5 - galvanic insulation and protected against overvoltage, polarity reversals and short circuit • Relay: <ul style="list-style-type: none"> - 2 relays, normally open, hysteresis, adjustable thresholds - non UL Recognized device: 230 V AC/3 A or 40 V DC/3 A (resistive load) - UL Recognized device: 30 V AC/42 V_{peak}/3 A or 60 V DC/1 A • Current: <ul style="list-style-type: none"> - 4...20 mA (3-wire with relays, 2-wire without relay) - sourcing or sinking (wiring dependant) - max. loop impedance: 900 Ω at 30 V DC, 600 Ω at 24 V DC, 50 Ω at 12 V DC, 800 Ω with a 115/230 V AC voltage supply - response time (10...90 %) for the measured value: 6 s (default) <p>Battery-powered indicator/totalizer</p> <ul style="list-style-type: none"> • Without output

DTS 1000011089 EN Version: X Status: RL (released | freigegeben | valide) printed: 24.03.2026

Voltage supply cable	Measuring device with standard output signal <ul style="list-style-type: none"> External diameter (cable): <ul style="list-style-type: none"> – 5...8 mm (with cable plug) – 6...12 mm (1 cable per cable gland) or 3...5 mm when using a multi-way seal (2 cables per cable gland) Cross section of wires: <ul style="list-style-type: none"> – 0.25...1.5 mm² (with cable plug) – 0.75 mm² (with cable gland) Cross section of the local ground wire: max. 0.75 mm²
	Battery-powered indicator/totalizer <ul style="list-style-type: none"> None

Product connections

Electrical connection	<ul style="list-style-type: none"> Variant 12...36 V DC: cable plug according to DIN EN 175301-803 or cable glands M20 × 1.5 Variant with batteries: None
-----------------------	---

Environment and installation

Ambient temperature	Operation and storage: <ul style="list-style-type: none"> variant 12...36 V DC: -10...+60 °C (+5...+140 °F) variant 115/230 V AC: -10...+50 °C (+5...+122 °F) variant with batteries: -10...+55 °C (+5...+131 °F)
---------------------	--

1.4. Batch controller

Note:

If the device is mounted in a humid environment or outside, then the maximum voltage allowed is **35 V DC** instead of 36 V DC.

Electrical data

Operating voltage (V+)	<ul style="list-style-type: none"> 12...36 V DC, max tolerance: -5 % or +10 % at 12 V DC, ±10 % at 36 V DC, filtered and regulated Connection to main supply: permanent, through external SELV (Safety Extra Low Voltage) and LPS (Limited Power Source) power supply 115/230 V AC, 50/60 Hz Voltage supply available inside the device: <ul style="list-style-type: none"> – supplied voltage: 27 V DC regulated – maximum current: 125 mA – integrated protection: 125 mA time delay fuse
Current consumption	With sensor, without consumption of digital input and pulse output <ul style="list-style-type: none"> With relays: <ul style="list-style-type: none"> – ≤ 100 mA (at 12 V DC) – ≤ 50 mA (at 36 V DC) – ≤ 55 mA (115/230 V AC) Without relay: <ul style="list-style-type: none"> – ≤ 70 mA (at 12 V DC) – ≤ 35 mA (at 36 V DC) – ≤ 40 mA (115/230 V AC)
Power consumption	115/230 V AC powered measuring device: 3 VA
Input	<ul style="list-style-type: none"> DI (1 to 4) Switching threshold V_{on}: 5...36 V DC Switching threshold V_{off} max.: 2 V DC Min. pulse duration: 100 ms Input impedance: 9.4 kΩ Galvanic insulation, protected against polarity reversals and voltage spike

Output	<ul style="list-style-type: none"> • Transistors (digital outputs DO1 and DO4): <ul style="list-style-type: none"> – potential-free – NPN or PNP (wiring dependant) – function: pulse output (by default for DO1), batch state (by default for DO4), configurable and parametrizable – 0...300 Hz – 5...36 V DC, 100 mA max., voltage drop at 100 mA: 2.7 V DC – duty cycle (pulse duration/period): > 0.45 – galvanic insulation, protected against overvoltage, polarity reversals and short-circuits • Relays (digital outputs DO2 and DO3): <ul style="list-style-type: none"> – 2 relays, normally open, parametrizable (by default: DO2 always configured to control the valve, parametrized of 100 % of the batch quantity and DO3 configured as alarm) – non UL Recognized device: 230 V AC/3 A or 40 V DC/3 A (resistive load) – UL Recognized device: 30 V AC/42 V_{peak}/3 A or 60 V DC/1 A – max. cutting power of 750 VA (resistive load)
Voltage supply cable	<ul style="list-style-type: none"> • External diameter (cable): <ul style="list-style-type: none"> – 6...12 mm (1 cable per cable gland) or – 4 mm when using a multi-way seal (2 cables per cable gland) • Cross section of wires: 0.75 mm²
Product connections	
Electrical connection	Cable glands M20 × 1.5
Environment and installation	
Ambient temperature	Operation and storage: <ul style="list-style-type: none"> • variant 12...36 V DC: -10...+60 °C (+5...+140 °F) • variant 115/230 V AC: -10...+50 °C (+5...+122 °F)

2. Product variants

2.1. Flowmeter

The flowmeter is available in two variants:

- Inline flowmeter with standard output signal (4...20 mA, frequency)
- Inline flowmeter as battery-powered indicator/totalizer



Flowmeter with standard output signal

The device operates on a 2- or 3-wire system and needs a 12...36 V DC or a 115/230 V AC power supply.

The device is equipped with:

- an analogue output (4...20 mA current output)
- a digital output (pulse output) and
- two totalizers.

Some variants are also fitted with two fully configurable relay outputs.

The device allows:

- through the digital or relay outputs
 - to switch a solenoid valve
 - to activate an alarm
 - to generate a flow rate proportional frequency
- through the analogue output to establish a control loop



Flowmeter as battery-powered indicator/totalizer

The device has no output and displays the instantaneous value as well as the amount of liquid that has flowed through.

2.2. Batch controller



The device needs a voltage supply of 12...36 V DC or 115/230 V AC.

The device is equipped with:

- four digital inputs (DI1 to DI4),
- two transistor outputs (DO1 configured as a pulse output and DO4 configured as state output, by default),
- two relay outputs (DO2 always configured to control the valve and by default parametrised of 100 % of the batch quantity and DO3 configured as alarm output by default),
- two volume or mass totalizers and two totalizers for the number of batches performed.

The second relay output can be used to activate another valve, to initiate alarms or to generate warnings.

When mounted in a pipe in series with one or two valves, the batch controller makes it possible to carry out a dosing of one or several quantities of liquids. The unit controls the opening of the valves and measures the quantity of the fluid which flows. The unit also closes the valves when the pre-set quantity has been delivered.

3. Approvals and conformities

3.1. General notes

- The approvals and conformities listed below must be stated when making enquiries. This is the only way to ensure that the product complies with all required specifications.
- Not all available variants of the device can be supplied with the below mentioned approvals or conformities.

3.2. Conformity

In accordance with the Declaration of Conformity, the product is compliant with the EU Directives.

3.3. Standards

The applied standards which are used to demonstrate compliance with the EU Directives are listed in the EU-Type Examination Certificate and/or the EU Declaration of Conformity.

3.4. Pressure Equipment Directive (PED)

The device conforms to article 4, paragraph 1 of the Pressure Equipment Directive (PED) 2014/68/EU under the following conditions:

Device used in a pipe

Note:

- The data in the table is independent of the chemical compatibility of the material and the fluid.
- PS = maximum admissible pressure (in bar), DN = nominal diameter of the pipe

Type of fluid	Conditions
Fluid group 1, Article 4, Paragraph 1.c.i	DN ≤ 25
Fluid group 2, Article 4, Paragraph 1.c.i	DN ≤ 32 or PS*DN ≤ 1000
Fluid group 1, Article 4, Paragraph 1.c.ii	DN ≤ 25 or PS*DN ≤ 2000
Fluid group 2, Article 4, Paragraph 1.c.ii	DN ≤ 200 or PS ≤ 10 or PS*DN ≤ 5000

3.5. North America (USA/Canada)

Approval	Description
	<p>Optional: UL Recognized for the USA and Canada The products are UL Recognized for the USA and Canada according to:</p> <ul style="list-style-type: none"> • UL 61010-1 (ELECTRICAL EQUIPMENT FOR MEASUREMENT, CONTROL, AND LABORATORY USE – Part 1: General Requirements) • CAN/CSA-C22.2 No. 61010-1

4. Materials

4.1. Bürkert resistApp

Bürkert resistApp – Chemical resistance chart

You want to ensure the reliability and durability of the materials in your individual application case? Verify your combination of media and materials on our website or in our resistApp.

[Start chemical resistance check](#)

DTS 1000011089 EN Version: X Status: RL (released | freigegeben | valide) printed: 24.03.2026

4.2. Material specifications

Flowmeter

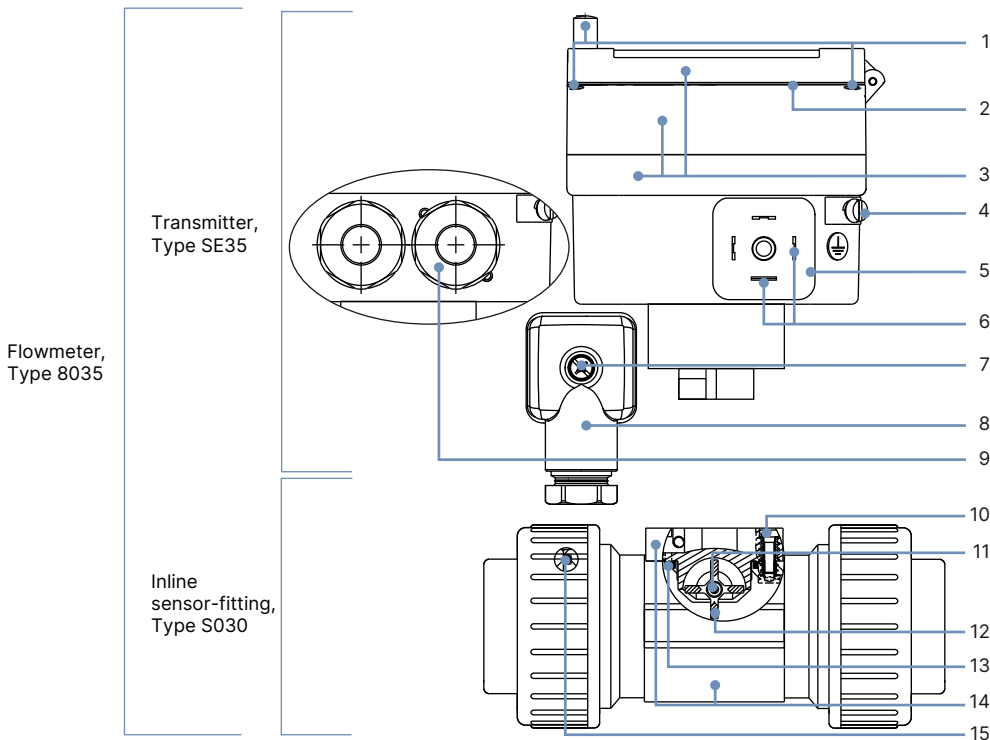

No.	Element	Material
1	Screws	Stainless steel
2	Front panel folio	Polyester
3	Housing, cover, lid	PC
4	Screws	Stainless steel
5	Male fixed plug (DIN EN 175301-803)	PA
6	Electrical contact	Sn
7	Screw	Stainless steel
8	Female cable plug (DIN EN 175301-803)	<ul style="list-style-type: none"> Body, contact holder and cable gland in PA Cable gland seal and flat seal in NBR
9	M20 × 1.5 cable gland	PA
10	Screws	Stainless steel
11	Axis and bearings	Ceramics (Al ₂ O ₃)
12	Paddle wheel	PVDF
13	Seal	FKM or EPDM (depending on the Inline sensor-fitting variant Type S030)
14	Sensor-fitting body, sensor armature	Stainless steel (316L - 1.4404), brass (CuZn ₃₉ Pb ₂), PVC, PP, PVDF (depending on the Inline sensor-fitting variant Type S030)
15	Seals	FKM or EPDM (depending on the Inline sensor-fitting variant Type S030 and only for true union connection with nut and solvent/fusion socket)

DTS 1000011089 EN Version: X Status: RL (released | freigegeben | valide) printed: 24.03.2026

Batch controller

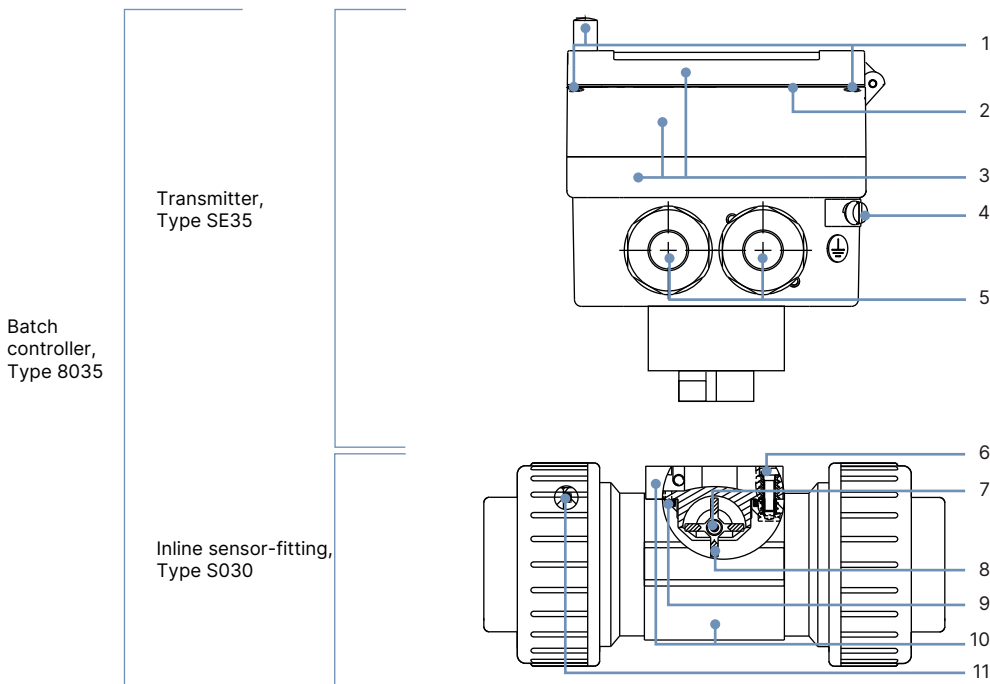

No.	Element	Material
1	Screws	Stainless steel
2	Front panel folio	Polyester
3	Housing, cover, lid	PC
4	Screws	Stainless steel
5	M20 × 1.5 cable gland	PA
6	Screws	Stainless steel
7	Axis and bearings	Ceramics (Al ₂ O ₃)
8	Paddle wheel	PVDF
9	Seal	FKM or EPDM (depending on the Inline sensor-fitting variant Type S030)
10	Sensor-fitting body, sensor armature	Stainless steel (316L - 1.4404), brass (CuZn ₃₉ Pb ₂), PVC, PP, PVDF (depending on the Inline sensor-fitting variant Type S030)
11	Seals	FKM or EPDM (depending on the Inline sensor-fitting variant Type S030 and only for true union connection with nut and solvent/fusion socket)

DTS 1000011089 EN Version: X Status: RL (released | freigegeben | valide) printed: 24.03.2026

5. Dimensions

5.1. Transmitter Type SE35

With cable plug (DIN EN 175301-803)

Note:

- Dimensions in mm, unless otherwise stated
- Flowmeter with standard output signal

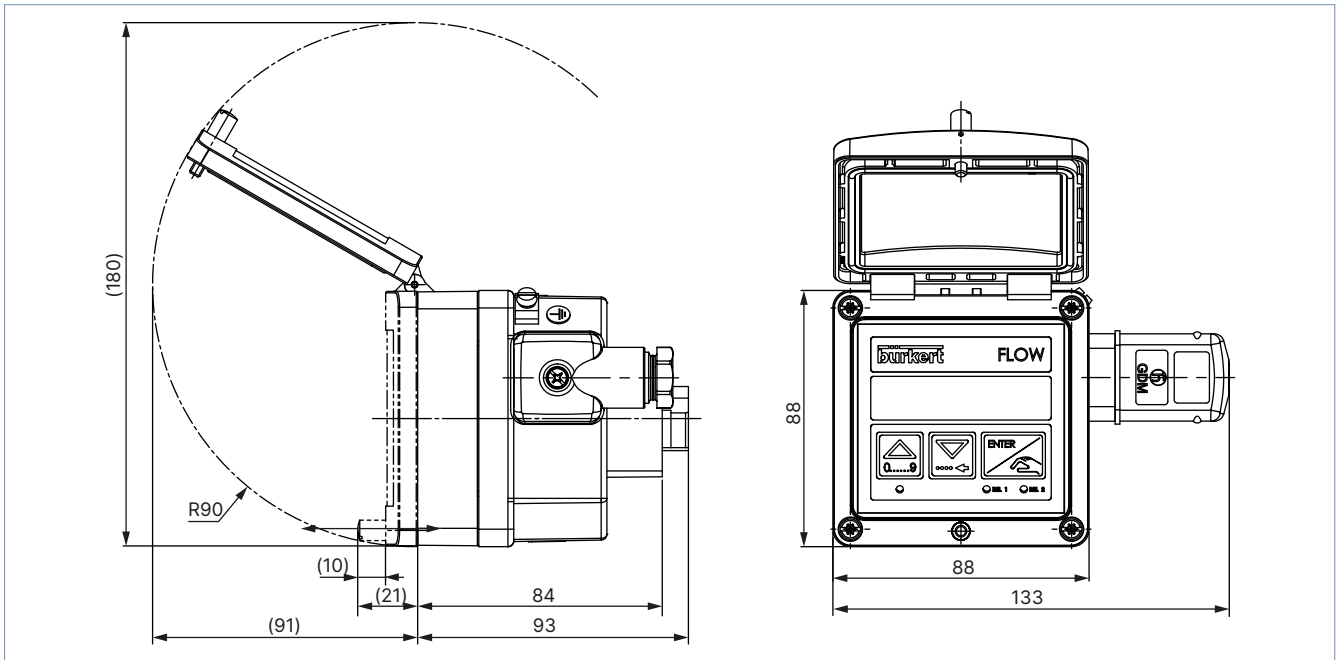

With M20 × 1.5 cable glands

Note:

- Dimensions in mm, unless otherwise stated
- Flowmeter with standard output signal or batch controller

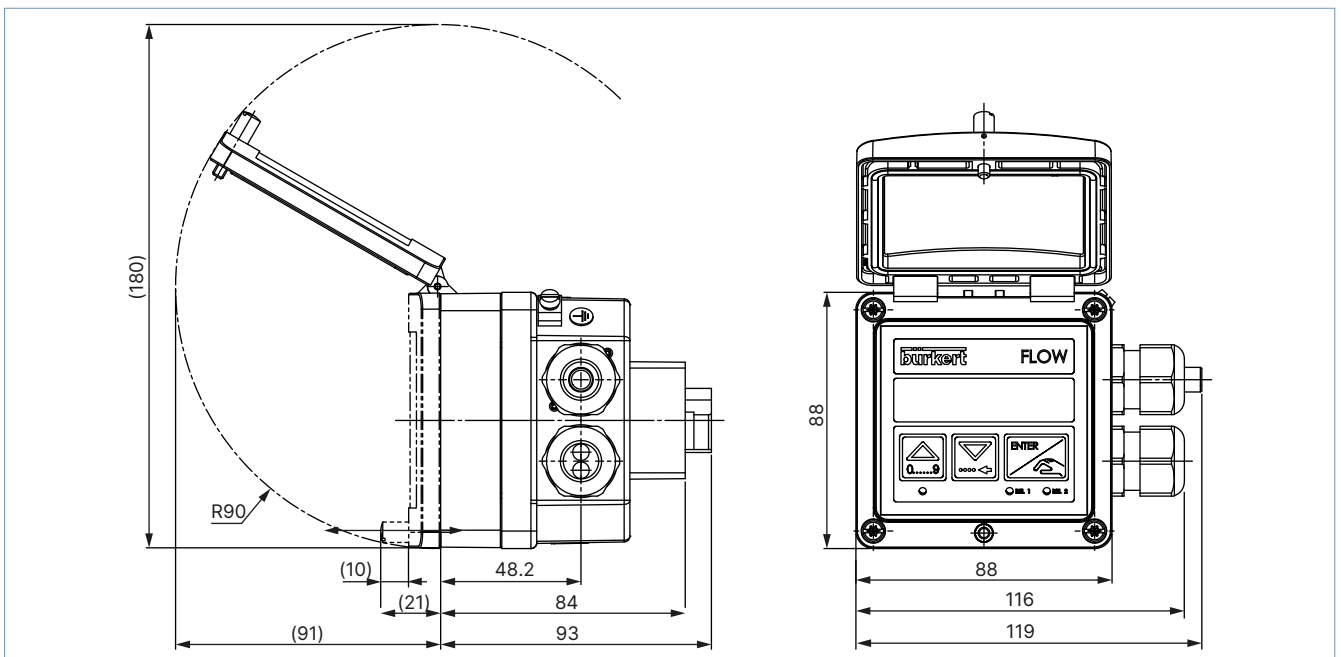

Battery-powered indicator/totalizer

Note:

Dimensions in mm, unless otherwise stated

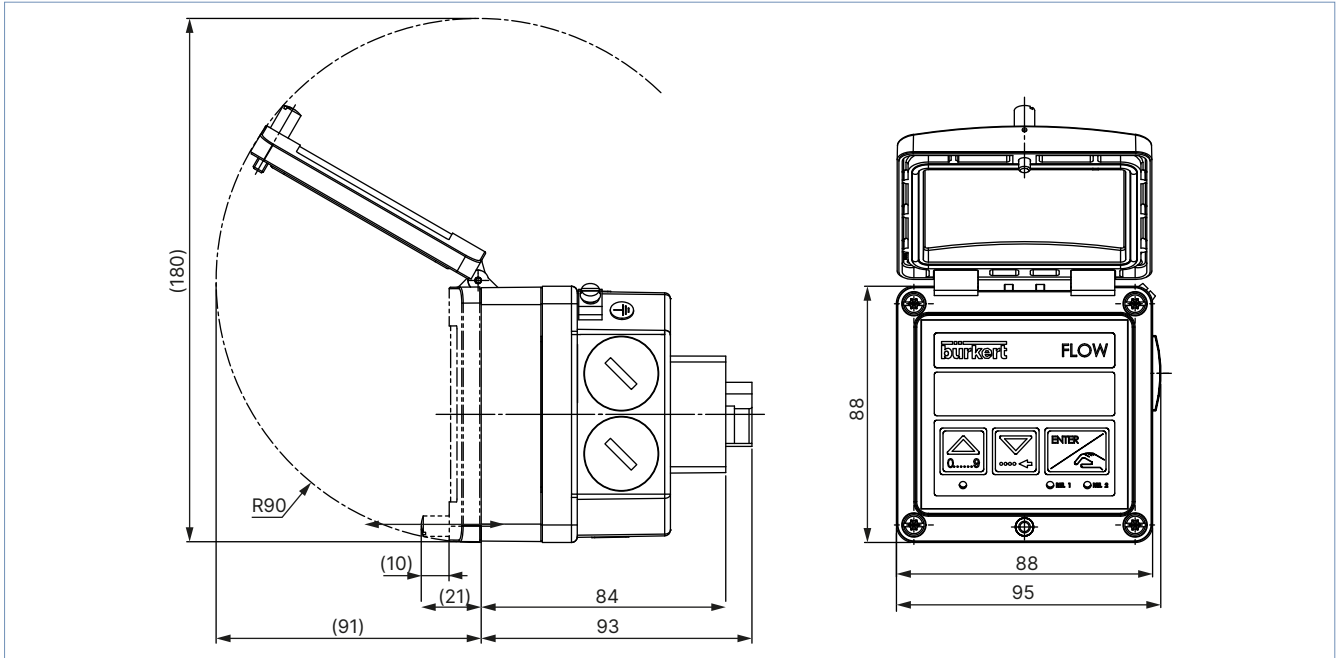

5.2. Transmitter Type SE35 mounted in an Inline sensor-fitting Type S030

Note:

Dimensions in mm, unless otherwise stated

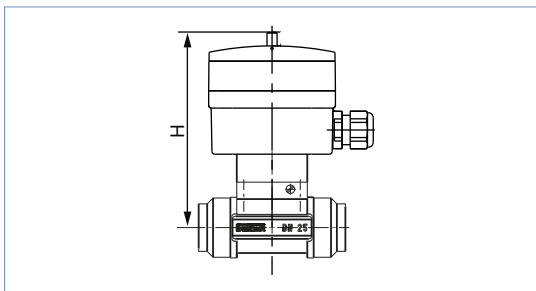

DN	H
06	134
08	134
15	139
20	137
25	137
32	140
40	144
50	151
65	151

6. Performance specifications

6.1. Pressure temperature diagram

Note:

The following diagram applies to the flowmeter or batch controller.

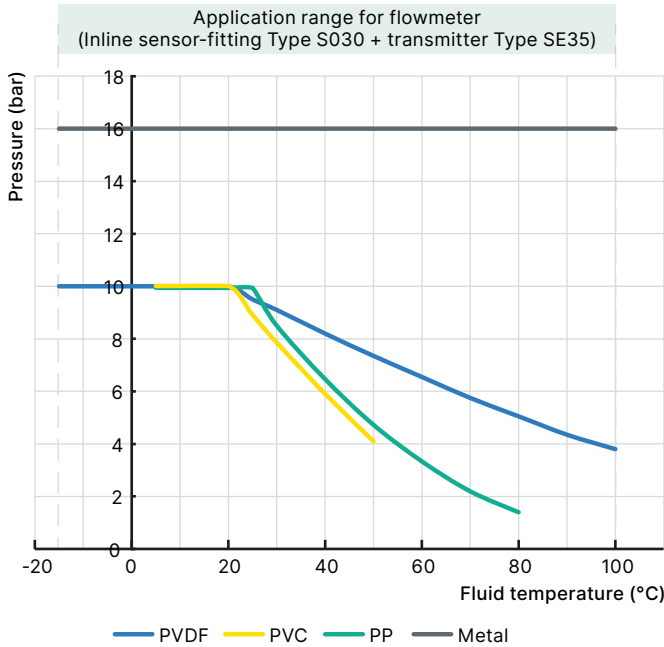

7. Product installation

7.1. Installation notes

Flow measurement

Note:

The device is not suitable for use in gaseous media and steam.

Minimum straight distances upstream and downstream of the sensor must be observed. These stabilizing distances depend on the pipe's design. Increasing these distances or installing a flow conditioner may be necessary to obtain the best accuracy. For more information, refer to EN ISO 5167-1.

EN ISO 5167-1 specifies the straight inlet and outlet distances that must be complied with when installing fittings in pipe lines in order to achieve calm flow conditions. The most commonly used elements that could lead to turbulence in the flow are shown below. The related minimum inlet and outlet distances that ensure a calm flow are also specified.

Make sure that the measurement conditions at the point of measurement are calm and problem-free.

DN = nominal diameter

Fluid direction ⇨

Regulating valve¹⁾

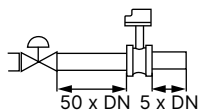

2 x 90° elbow joint

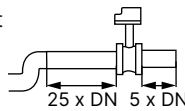

Expansion²⁾

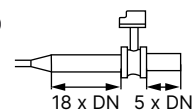

2 x 90° elbow joint
3 dimensional

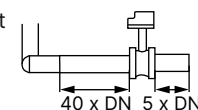

90° elbow joint
or T-piece

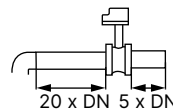

Reduction

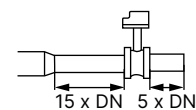

1.) If the valve cannot be mounted after the measuring device, the minimal distances have to be respected.

2.) If an expansion cannot be avoided, the minimal distances have to be respected.

Take the minimum flow velocity into account.

The device can be installed in either horizontal or vertical pipes, but following additional conditions should be respected:

- The pipe always has to be filled with fluid at all times near the device.
- The pipe design must be such that no air bubbles or cavitation can form within the medium near the device at any time.

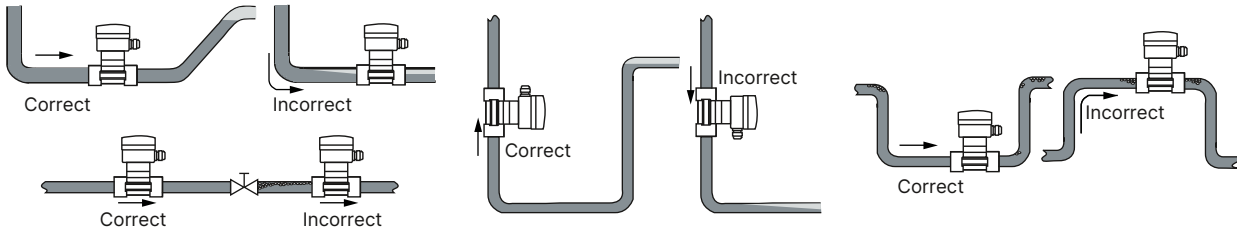

Pressure and temperature ratings must be respected according to the selected fitting material. The suitable pipe size is selected using the diagram in the chapter "Selection of the nominal diameter" of the **data sheet Type S030** ▶.

8. Product operation

8.1. Measurement principle

When liquid flows through the pipe, the paddle wheel with 4 inserted magnets is set in rotation, producing a measuring signal in the transducer (coil or Hall sensor depending on variant). The frequency of this signal is proportional to the flow velocity of the fluid. A K factor, specific to each pipe, enables the conversion of this frequency into a flow rate/volume.

This K factor is available in the Inline sensor-fittings' user manual, see **Type S030** ▶.

Flowmeter:

The electronics converts the measured signal into several outputs (according to the device variant) and displays the actual value. The totalizers are used to obtain the volume of fluid that are passed through the pipe.

The electrical connection for the flowmeter with standard output signal is provided via a cable plug according to DIN EN 175301-803 or on a terminal block via two cable glands (according to the flowmeter variant).

Batch controller:

The electronics converts the measured signal and displays the actual value of the volume or mass. The electrical connection is provided on a terminal block via two cable glands.

8.2. Functional overview

Display and operating keys

The display allows to:

- read the value of certain parameters e.g. for the flowmeter, the measured flow rate and the main totalizer
- set parameters of the device by means of 3 keys
- read the configuration of the device
- be warned of certain events.

Display and operating keys	No.	Description
	1	"Back" key: <ul style="list-style-type: none"> • to increment the selected digit • to go back to the previous function • Read the dosing history (only for batch controller)
	2	"Next" key: <ul style="list-style-type: none"> • to select the character at the left • to go to the next function • to read messages (only with Inline flowmeter as battery-powered indicator/totalizer and with batch controller)
	3	"Confirm" key: <ul style="list-style-type: none"> • to confirm the displayed function • to confirm the set parameters
	4	<ul style="list-style-type: none"> • For Inline flowmeter with a standard output signal <ul style="list-style-type: none"> - status LED of relay 2 • For batch controller <ul style="list-style-type: none"> - status LED of relay output DO3 (LED ON = contact closed)
	5	<ul style="list-style-type: none"> • For Inline flowmeter with a standard output signal <ul style="list-style-type: none"> - status LED of relay 1 • For batch controller <ul style="list-style-type: none"> - status LED of relay output DO2 (LED ON = contact closed)
	6	Device status: <ul style="list-style-type: none"> • No status for Inline flowmeter with a standard output signal • For Inline flowmeter as a battery-powered indicator/totalizer <ul style="list-style-type: none"> - off: the device operates correctly. - blinking orange: a warning message has been generated in the information menu. - blinking red: an error message has been generated. • For batch controller <ul style="list-style-type: none"> - green: the device operates correctly. - orange: an alarm related to the dosing and/or a warning messages has been generated in the information menu. - red: an error message has been generated in the information menu. - blinking, whatever the colour: <ul style="list-style-type: none"> - slow blinking: the dosing has been interrupted. - Fast blinking during dosing: a dosing-related alarm has been generated. - Fast blinking when no dosing is being done: A remote query of the Information menu is currently in progress or the inputs/outputs are being checked for proper operation.

The device can be calibrated by means of the K factor (proportionality factor) of the fitting, or via the teach function. User adjustments, such as engineering units, output, filter settings and bar graph can be carried out directly on the device.

DTS 1000011089 EN Version: X Status: RL (released | freigegeben | valide) printed: 24.03.2026

Operating levels

Flowmeter with standardized output signal

The device has 2 operating levels:

- the process level
- the configuration level, which comprises the parameters and the test menus

Operating level	Functions
Process	This level allows: <ul style="list-style-type: none"> • to read: <ul style="list-style-type: none"> – the value of the measured flow – the value of the 4...20 mA output – the main totalizer value – the daily totalizer value • to reset the daily totalizer • to access the parameters and test menus of the configuration level
Configuration - parameters menu	This level allows: <ul style="list-style-type: none"> • to set the required operation parameters: <ul style="list-style-type: none"> – language – engineering units (International measurement units) – K-factor/Teach function – 4...20 mA current output – pulse output – relay (on devices with relays) – filter (damping) – reset both totalizers
Configuration - test menu	This level allows: <ul style="list-style-type: none"> • to adjust the Offset and Span of the 4...20 mA current output • to read the rotational frequency of the paddle wheel • to check the proper operation of the outputs with a simulated flow rate

Flowmeter as battery-powered indicator/totalizer

The device has 2 operating levels:

- the process level
- the configuration level, which comprises the parameters, the test and the information menus

Operating level	Functions
Process	This level allows: <ul style="list-style-type: none"> • to read: <ul style="list-style-type: none"> – the value of the measured flow – the main totalizer value – the daily totalizer value • to reset the daily totalizer • to access the parameters, test and information menus of the configuration level
Configuration - parameters menu	This level allows: <ul style="list-style-type: none"> • to set the required operation parameters: <ul style="list-style-type: none"> – language – engineering units (International measurement units) – K-factor/Teach function – filter (damping) – reset both totalizers
Configuration - test menu	This level allows: <ul style="list-style-type: none"> • to read the rotational frequency of the paddle wheel • to generate warning or fault messages

DTS 1000011089 EN Version: X Status: RL (released | freigegeben | valide) printed: 24.03.2026

Configuration - information menu	This level allows: <ul style="list-style-type: none"> • to read <ul style="list-style-type: none"> – the battery charge status – the warning or error messages
----------------------------------	--

Batch controller

The device has 2 operating levels:

- The process level
- The configuration level, which includes the parameters, the test, the information and the history menus

Operating level	Functions
Process	This level allows: <ul style="list-style-type: none"> • to start a dosing • to read: <ul style="list-style-type: none"> – the main totalizer value for the measured liquid quantity – the daily totalizer value for the measured liquid quantity – the main totalizer value of the performed dosings – the daily totalizer value of the performed dosings • to reset <ul style="list-style-type: none"> – the daily volume or mass totalizer – the daily totalizer of the performed dosings • to access the parameters, test, information and history menus of the configuration level
Configuration - parameters menu	This level allows: <ul style="list-style-type: none"> • to set the required operation parameters: <ul style="list-style-type: none"> – language – engineering units (International measurement units) – K-factor/Teach function – dosing mode (optional) – overflow – alarm – outputs – resetting the 2 volume or mass totalizers – resetting the 2 totalizers of the performed dosings – resetting the history menu – backlight
Configuration - test menu	This level allows: <ul style="list-style-type: none"> • to check: <ul style="list-style-type: none"> – the inputs functions – the outputs functions – the paddle-wheel operation • to monitor: <ul style="list-style-type: none"> – the flow rate in the pipe – the value of the daily volume or mass totalizer – the number of performed dosings • to save/restore: <ul style="list-style-type: none"> – the current user configuration – the saved configuration – the default configuration of the device
Configuration - history menu	This level allows the last 10 dosing quantities to be read.
Configuration - information menu	This level allows to read the warning or error messages generated

DTS 1000011089 EN Version: X Status: RL (released | freigegeben | valide) printed: 24.03.2026

8.3. Function modes

Flowmeter with standardized output signal

- 4...20 mA output + pulse
 - 4...20 mA output + pulse + relay output
- Hysteresis switching mode (both relays) for the output, inverted or not

Hysteresis mode

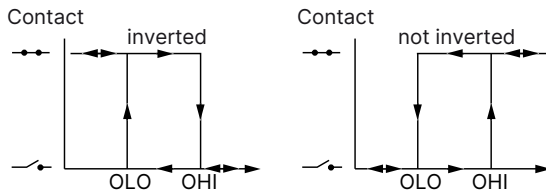

Batch controller

The following dosing modes are possible:

- **Locally started dosing of**
 - a **free quantity**: the user enters the quantity to be dosed and starts the dosing via the keypad.
 - a preset **quantity**: the user selects a preset quantity and starts the dosing via the keypad.
- **Dosing controlled by a PLC unit**: the user selects a preset quantity and starts the dosing using binary inputs.
- **Locally/remote selection of preset quantity and dosing controlled by a PLC unit**: the user selects a preset quantity and via the keypad or using binary inputs and starts the dosing using binary inputs.
- **Automatic dosing controlled by variation of pulse** duration modulation: the volume to be dosed is directly proportional to the pulse duration.
- **Locally/remote dosing determined by teach-in**:
 - teach-in of the dosing quantity via the keypad
 - teach-in of the dosing quantity using binary inputs.

9. Product design and assembly

9.1. Product assembly

Note:

- The device Type 8035 is made up of a Bürkert Inline sensor-fitting Type S030 equipped with a paddle wheel sensor and a transmitter Type SE35.
- The electronic housing of the Type 8035 integrates the electronic board with display, setting parameter keys as well as a transducer (coil for battery indicator/totalizer variant or Hall for the other variants).
- The Inline sensor-fitting Type S030 ensures simple installation into pipes from DN 06...DN 65. The transmitter Type SE35 can be mounted on any Inline sensor-fitting Type S030 and fastened with a bayonet catch, see **data sheet Type S030** ▶ for more information.

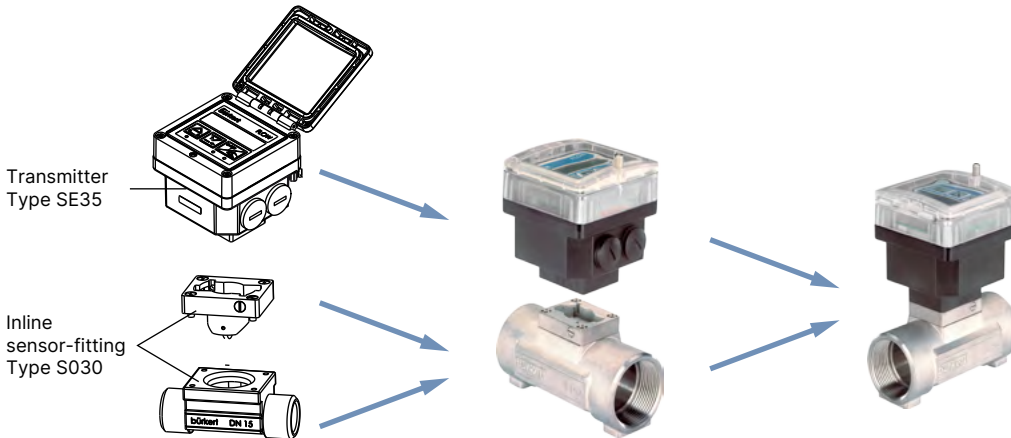

10. Networking and combination with other Bürkert products

10.1. Flowmeter with a standard output signal

Example:



4...20 mA output	Pulse output	Relay output
Type 8802 ▶ (2301 and 8693) ELEMENT Continuous control valve systems	Type 6212 ▶ Servo-assisted 2/2-way diaphragm valve	Type 6281 ▶ Servo-assisted 2/2-way diaphragm valve

DTS 1000011089 EN Version: X Status: RL (released | freigegeben | valide) printed: 24.03.2026

10.2. Batch controller

Example:



11. Ordering information

11.1. Bürkert eShop



Bürkert eShop – Bequem bestellt und schnell geliefert

Sie möchten Ihr gewünschtes Bürkert-Produkt oder -Ersatzteil schnell finden und direkt bestellen? Unser Onlineshop ist rund um die Uhr für Sie erreichbar. Melden Sie sich gleich an und nutzen Sie die Vorteile.

Jetzt online einkaufen

11.2. Recommendation regarding product selection

A complete Type 8035 Inline flowmeter or batch controller consists of a compact Type SE35 flow transmitter and a Bürkert Inline sensor-fitting Type S030.

See **data sheet Type S030 ▶** for more information.

Two different components must be ordered to obtain a complete device. The following information is required:

- **Article no.** of the compact Type SE35 flow transmitter (see chapter **"11.4. Ordering chart" on page 23**)
- **Article no.** of the Type S030 Inline sensor-fitting (see **data sheet Type S030 ▶**)

11.3. Bürkert Produktfilter



Bürkert Produktfilter – Schnell zum passenden Produkt

Sie möchten anhand Ihrer technischen Anforderungen einfach und bequem selektieren? Nutzen Sie den Bürkert Produktfilter und finden Sie unseren passenden Artikel für Ihre Anwendung.









Jetzt Produkte filtern

11.4. Ordering chart

Flowmeter

Note:



The following variants have at least 2 volume totalizers.

Operating voltage	Sensor variant	Output	UL approval	Electrical connection	Article no.
Flow transmitter Type SE35 with standard output signal					
12...36 V DC	Hall	4...20 mA (2 wires) + Pulse	—	Female cable plug DIN EN 175301-803	444005 
			UL Recognized		570477 
			—	2 cable glands	444006 
			UL Recognized		553432 
	Hall	4...20 mA (3 wires) + Pulse + 2 relays	—	2 cable glands	444007 
			UL Recognized	2 cable glands	553433 
115/230 V AC	Hall	4...20 mA (2 wires) + Pulse	—	2 cable glands	423922 
	Hall	4...20 mA (3 wires) + Pulse + 2 relays	—	2 cable glands	423924 
Flow transmitter Type SE35 as indicator					
4 × 1.5 V DC AA batteries	Coil	Keine	—	None	423921 





Batch controller

Note:

The following variants have at least 2 volume or mass totalizers and 2 totalizers of the number of dosing performed.

Operating voltage	Sensor variant	Input	Output	UL approval	Electrical connection	Article no.
12...36 V DC	Hall	4 digital inputs (DI1...DI4)	2 transistor outputs (DO1 and DO4) + 2 relay outputs (DO2 and DO3)	—	2 cable glands	443360 
				UL Recognized		564398 
—				423926 		
115/230 V AC						

11.5. Ordering chart accessories

Description	Article no.
For flowmeter or batch controller	
Set with two cable glands M20 × 1.5, two neoprene flat seals for cable gland or plug, two screw plugs M20 × 1.5 and two multi-way seals 2 × 6 mm	449755 
Set with two adapters M20 × 1.5 /NPT ½, two neoprene flat seals for cable gland or plug and two screw plugs M20 × 1.5	551782 
Set with a stopper for unused cable gland M20 × 1.5, a multi-way seal 2 × 6 mm for cable gland, a black EPDM seal for the sensor and a mounting instruction sheet	551775 
For flowmeter	
Female cable plug, 4-pin (3 conductors + protective conductor), form A according to DIN EN 175301-803 with cable gland (Type 2518 ▶)	572264 
Female cable plug 32 mm, 4-pin (3 conductors + protective conductor), form A according to DIN EN 175301-803, with NPT ½ reduction without cable gland (Type 2509 ▶)	162673 
For batch controller	
Set with 8 FLOW front panel films	553191 