

- Actuating force 1000 N
- Nominal voltage AC/DC 24 V
- Control modulating, communicative 2...10 V variable
- Stroke 20 mm
- Communication via Belimo MP-Bus
- Conversion of sensor signals

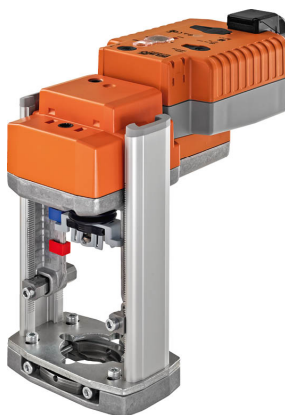

## Technical data

|                               |                                    |   |
|-------------------------------|------------------------------------|---|
| <b>Electrical data</b>        | Nominal voltage                    | AC/DC 24 V  |
|                               | Nominal voltage frequency          | 50/60 Hz  |
|                               | Nominal voltage range              | AC 19.2...28.8 V / DC 21.6...28.8 V   |
|                               | Power consumption in operation     | 4.5 W   |
|                               | Power consumption in rest position | 1.5 W   |
|                               | Power consumption for wire sizing  | 9 VA  |
|                               | Connection supply / control        | Terminals 4 mm <sup>2</sup> (cable ø4...10 mm)  |
|                               | Parallel operation                 | Yes (note the performance data)   |
| <b>Data bus communication</b> | Communicative control              | MP-Bus  |
|                               | Number of nodes                    | MP-Bus max. 8   |
| <b>Functional data</b>        | Actuating force motor              | 1000 N  |
|                               | Operating range Y                  | 2...10 V  |
|                               | Input impedance                    | 100 kΩ  |
|                               | Operating range Y variable         | Start point 0.5...30 V<br>End point 2.5...32 V  |
|                               | Operating modes optional           | Open/close<br>3-point (AC only)<br>Modulating (DC 0...32 V)   |
|                               | Position feedback U                | 2...10 V  |
|                               | Position feedback U note           | Max. 0.5 mA   |
|                               | Position feedback U variable       | Start point 0.5...8 V<br>End point 2.5...10 V   |
|                               | Setting fail-safe position         | Stem 0...100%, adjustable (POP rotary knob)   |
|                               | Bridging time (PF)                 | 2 s   |
|                               | Bridging time (PF) variable        | 0...10 s  |
|                               | Position accuracy                  | ±5%   |
|                               | Manual override                    | with push-button  |
|                               | Stroke                             | 20 mm   |
|                               | Running time motor                 | 35 s / 20 mm  |
|                               | Running time motor variable        | 35...90 s   |
|                               | Running time fail-safe             | 35 s / 20 mm  |
|                               | Adaptation setting range           | manual (automatic on first power-up)  |
|                               | Adaptation setting range variable  | No action<br>Adaptation when switched on<br>Adaptation after pushing the manual override button           |
|                               | Override control                   | MAX (maximum position) = 100%<br>MIN (minimum position) = 0%<br>ZS (intermediate position, AC only) = 50% |
|                               | Override control variable          | MAX = (MIN + 33%)...100%<br>ZS = MIN...MAX  |

|                        |  |   |
|------------------------|--|---|
| <b>Functional data</b> | Sound power level, motor               | 60 dB(A)  |
|                        | Sound power level, fail-safe           | 60 dB(A)  |
|                        | Position indication                    | Mechanical, 5...20 mm stroke  |
| <b>Safety data</b>     | Protection class IEC/EN                | III, Safety Extra-Low Voltage (SELV)  |
|                        | Power source UL                        | Class 2 Supply  |
|                        | Degree of protection IEC/EN            | IP54  |
|                        | Degree of protection NEMA/UL           | NEMA 2  |
|                        | Enclosure                              | UL Enclosure Type 2   |
|                        | EMC                                    | CE according to 2014/30/EU  |
|                        | Certification IEC/EN                   | IEC/EN 60730-1 and IEC/EN 60730-2-14  |
|                        | UL Approval                            | cULus according to UL60730-1A, UL60730-2-14 and CAN/CSA E60730-1<br>The UL marking on the actuator depends on the production site, the device is UL-compliant in any case |
|                        | Type of action                         | Type 1.AA   |
|                        | Rated impulse voltage supply / control | 0.8 kV  |
|                        | Pollution degree                       | 3   |
|                        | Ambient humidity                       | Max. 95% RH, non-condensing   |
|                        | Ambient temperature                    | 0...50°C [32...122°F]   |
|                        | Storage temperature                    | -40...80°C [-40...176°F]  |
| Servicing              | maintenance-free                       |   |
| <b>Weight</b>          | Weight                                 | 2.1 kg  |
| <b>Terms</b>           | Abbreviations                          | POP = Power off position / fail-safe position<br>CPO = Controlled power off / controlled fail-safe<br>PF = Power fail delay time / bridging time                          |

**Safety notes**

- This device has been designed for use in stationary heating, ventilation and air-conditioning systems and must not be used outside the specified field of application, especially in aircraft or in any other airborne means of transport.
- Outdoor application: only possible in case that no (sea) water, snow, ice, insulation or aggressive gases interfere directly with the device and that it is ensured that the ambient conditions remain within the thresholds according to the data sheet at any time.
- Only authorised specialists may carry out installation. All applicable legal or institutional installation regulations must be complied during installation.
- The switch for changing the direction of motion and so the closing point may be adjusted only by authorised specialists. The direction of motion is critical, particularly in connection with frost protection circuits.
- The device may only be opened at the manufacturer's site. It does not contain any parts that can be replaced or repaired by the user.
- The device contains electrical and electronic components and must not be disposed of as household refuse. All locally valid regulations and requirements must be observed.

Product features

**Mode of operation** Conventional operation:

The actuator is connected with a standard control signal of 0...10 V and moves to the position defined by the control signal at the same time as the integrated capacitors are loaded. Interrupting the supply voltage causes the valve to be moved to the selected fail-safe position by means of stored electrical energy.

Operation on Bus:

The actuator receives its digital control signal from the higher level controller via the MP-Bus and drives to the position defined. Connection U serves as communication interface and does not supply an analogue measuring voltage.

**Pre-charging time (start up)**

The capacitor actuators require a pre-charging time. This time is used for charging the capacitors up to a usable voltage level. This ensures that, in the event of a power failure, the actuator can move at any time from its current position into the preset fail-safe position.

The duration of the pre-charging time depends mainly on following factors:

- Duration of the power failure
- PF delay time (bridging time)

Typical pre-charging time

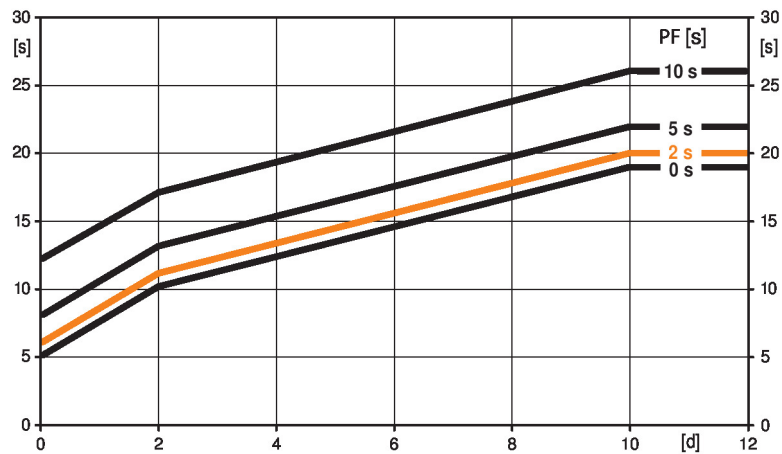

[d] = Power failure in days

[s] = Pre-charging time in seconds

PF[s] = Bridging time

Calculation example: Given a power failure of 3 days and a bridging time (PF) set at 5 s, the actuator requires a pre-charging time of 14 s after the power has been reconnected (see graphic).

| PF [s] | [d] |    |    |    |     |
|--------|-----|----|----|----|-----|
|        | 0   | 1  | 2  | 7  | ≥10 |
| 0      | 5   | 8  | 10 | 15 | 19  |
| 2      | 6   | 9  | 11 | 16 | 20  |
| 5      | 8   | 11 | 13 | 18 | 22  |
| 10     | 12  | 15 | 17 | 22 | 26  |

**Delivery condition (capacitors)**

The actuator is completely discharged after delivery from the factory, which is why the actuator requires approximately 20 s pre-charging time before initial commissioning in order to bring the capacitors up to the required voltage level.

**Bridging time**

Power failures can be bridged up to a maximum of 10 s.

In the event of a power failure, the actuator will remain stationary in accordance with the set bridging time. If the power failure is greater than the set bridging time, the actuator will move into the selected fail-safe position.

The bridging time set at the factory is 2 s. It can be modified on site in operation by means of the Belimo service tool MFT-P.

Settings: The rotary knob must not be set to the "Tool" position!

For retroactive adjustments of the bridging time with the Belimo service tool MFT-P or with the ZTH EU adjustment and diagnostic device only the values need to be entered.

|   |   |
|---|---|
| <b>Setting fail-safe position (POP)</b> | <p>The rotary knob fail-safe position can be used to adjust the desired fail-safe position from 0...100% in 10% increments. The rotary knob refers to the adapted or programmed height of stroke. In the event of a power failure, the actuator will move to the selected fail-safe position, taking into account the bridging time (PF) of 2 s set at the factory.</p> <p>Settings: The rotary knob must be set to the «Tool» position for retroactive settings of the fail-safe position with the Belimo service tool MFT-P. Once the rotary knob is set back to the range 0...100%, the manually set value will have positioning authority.</p>                                  |
| <b>Converter for sensors</b>            | <p>Connection option for a sensor (passive or active sensor or switching contact). The MP actuator serves as an analogue/digital converter for the transmission of the sensor signal via MP-Bus to the higher level system.</p>   |
| <b>Parametrisable actuators</b>         | <p>The factory settings cover the most common applications. Single parameters can be modified with the Belimo Service Tools MFT-P or ZTH EU.</p>  |
| <b>Mounting on third-party valves</b>   | <p>The Retrofit actuators for installation on a wide range of valves from various manufacturers are comprised of an actuator, bracket, universal valve neck adapter and universal valve stem adapter. Adapt the valve neck and valve stem to begin with, then attach the Retrofit bracket to the valve neck adapter. Now fit the Retrofit actuator into the bracket and connect it to the valve. Whilst taking the position of the valve closing point into account, secure the actuator to the bracket and then conduct the commissioning process. The valve neck adapter/actuator can be rotated by 360° on the valve neck, provided the size of the installed valve permits.</p> |
| <b>Mounting on Belimo valves</b>        | <p>Use standard actuators from Belimo for mounting on Belimo globe valves. The installation of Retrofit actuators on Belimo globe valves is technically possible.</p>   |
| <b>Manual override</b>                  | <p>Manual control with push-button possible - temporary. The gear train is disengaged and the actuator decoupled for as long as the button is pressed.</p> <p>The stroke can be adjusted by using a hexagon socket screw key (4 mm), which is inserted into the top of the actuator. The stroke shaft extends when the key is rotated clockwise.</p>  |
| <b>High functional reliability</b>      | <p>The actuator is overload protected, requires no limit switches and automatically stops when the end stop is reached.</p>   |
| <b>Home position</b>                    | <p>Factory setting: Actuator stem is retracted.</p> <p>The first time the supply voltage is switched on, i.e. at the time of commissioning, the actuator carries out an adaptation, which is when the operating range and position feedback adjust themselves to the mechanical setting range.</p> <p>The actuator then moves into the position defined by the control signal.</p>  |
| <b>Adaptation and synchronisation</b>   | <p>An adaptation can be triggered manually by pressing the "Adaptation" button or with the PC-Tool. Both mechanical end stops are detected during the adaptation (entire setting range).</p> <p>Automatic synchronisation after pressing the manual override button is configured. The synchronisation is in the home position (0%).</p> <p>The actuator then moves into the position defined by the control signal.</p> <p>A range of settings can be adapted using the PC-Tool (see MFT-P documentation)</p>  |
| <b>Setting direction of motion</b>      | <p>When actuated, the stroke direction switch changes the running direction in normal operation. The stroke direction switch has no influence on the fail-safe position which has been set.</p>   |

**Accessories**

| Gateways               | Description                          | Type       |
|------------------------|--------------------------------------|------------|
|                        | Gateway MP to BACnet MS/TP           | UK24BAC    |
|                        | Gateway MP to Modbus RTU             | UK24MOD    |
| Electrical accessories | Description                          | Type       |
|                        | Auxiliary switch 2 x SPDT add-on     | S2A-H      |
|                        | MP-Bus power supply for MP actuators | ZN230-24MP |
| Mechanical accessories | Description                          | Type       |
|                        | Spacer ring for LDM, stroke 20 mm    | ZNV-203    |
|                        | Spacer ring for Sauter, stroke 20 mm | ZNV-204    |
|                        | Adapter kit Danfoss                  | ZNV-205    |

| Tools | Description   | Type    |
|-------|---|---------|
|       | Service Tool, with ZIP-USB function, for parametrisable and communicative Belimo actuators, VAV controller and HVAC performance devices | ZTH EU  |
|       | Belimo PC-Tool, Software for adjustments and diagnostics  | MFT-P   |
|       | Adapter for Service-Tool ZTH  | MFT-C   |
|       | Connecting cable 5 m, A: RJ11 6/4 ZTH EU, B: 6-pin for connection to service socket   | ZK1-GEN |
|       | Connecting cable 5 m, A: RJ11 6/4 ZTH EU, B: free wire end for connection to MP/PP terminal   | ZK2-GEN |

Electrical installation



Supply from isolating transformer.

Parallel connection of other actuators possible. Observe the performance data.

Direction of stroke switch factory setting: Actuator stem retracted (▲).

Wiring diagrams

Operation on the MP-Bus

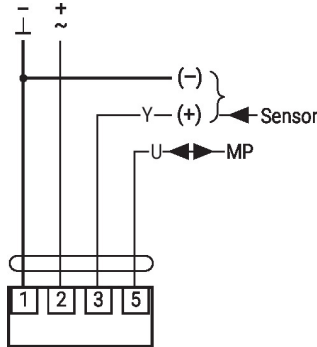

AC/DC 24 V, modulating

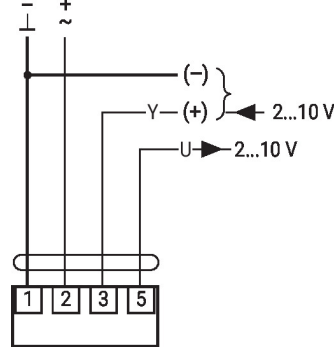

Functions

Functions with basic values (conventional mode)

Override control with AC 24 V with relay contacts

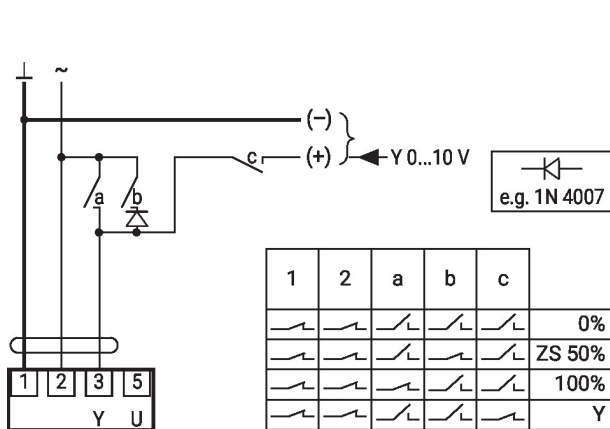

Override control with AC 24 V with rotary switch

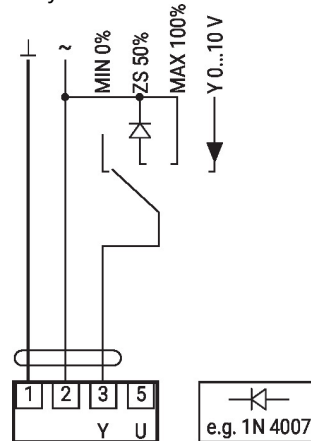

Control remotely 0...100% with positioner SG..

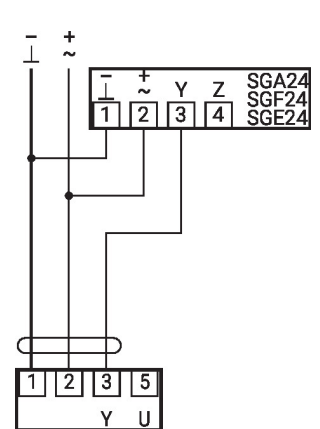

Minimum limit with positioner SG..

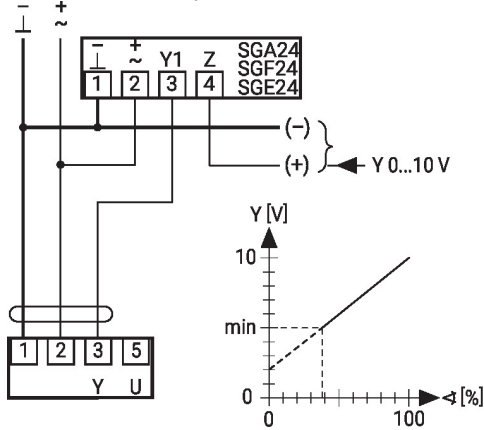

Primary/secondary operation (position-dependent)

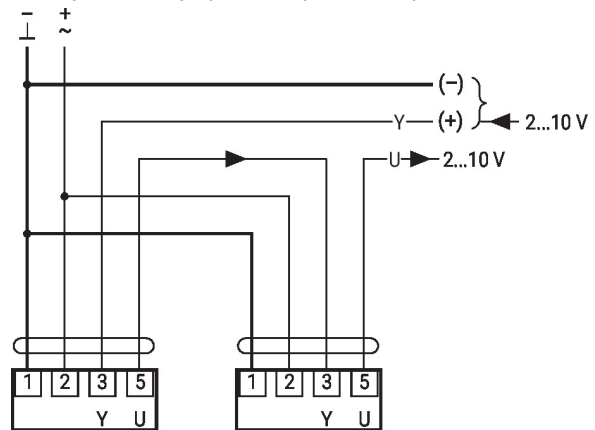

Control with 4...20 mA via external resistor

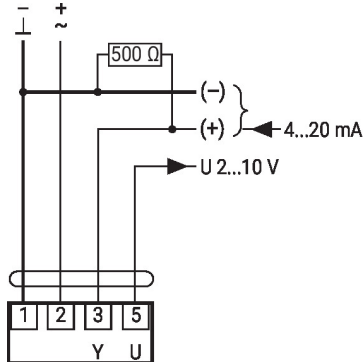

**Caution:**

The operating range must be set to DC 2...10 V.

The 500 Ohm resistor converts the 4...20 mA current signal to a voltage signal DC 2...10 V.

Functional check

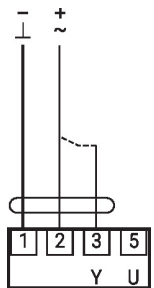

**Procedure**

1. Connect 24 V to connections 1 and 2
2. Disconnect connection 3:
  - with direction of rotation L: Actuator rotates to the left
  - with direction of rotation R: Actuator rotates to the right
3. Short-circuit connections 2 and 3:
  - Actuator runs in opposite direction

Functions with specific parameters (Parametrisation necessary)

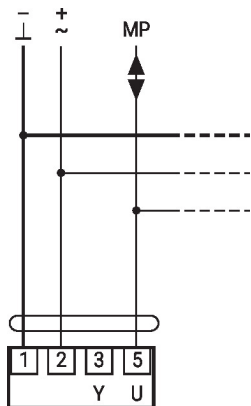

Max. 8 additional MP-Bus nodes

MP-Bus Network topology

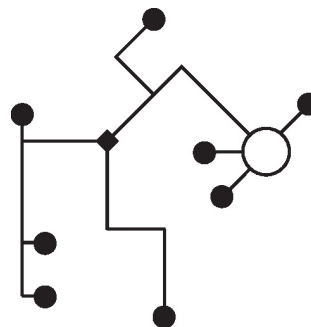

There are no restrictions for the network topology (star, ring, tree or mixed forms are permitted).

Supply and communication in one and the same 3-wire cable

- no shielding or twisting necessary
- no terminating resistors required

Connection of active sensors

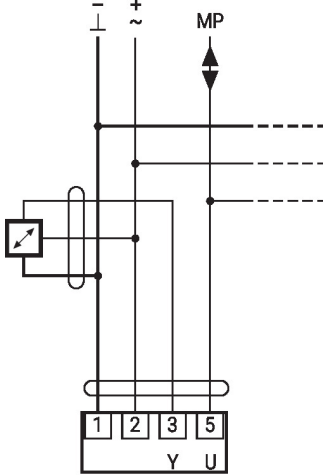

- Max. 8 additional MP-Bus nodes
- Supply AC/DC 24 V
- Output signal 0...10 V (max. 0...32 V)
- Resolution 30 mV

Connection of external switching contact

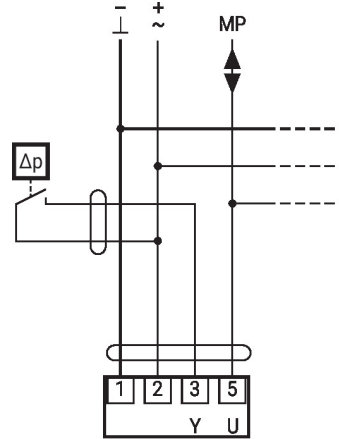

- Max. 8 additional MP-Bus nodes
- Switching current 16 mA @ 24 V
- Start point of the operating range must be parametrised on the MP actuator as  $\geq 0.5$  V

Connection of passive sensors

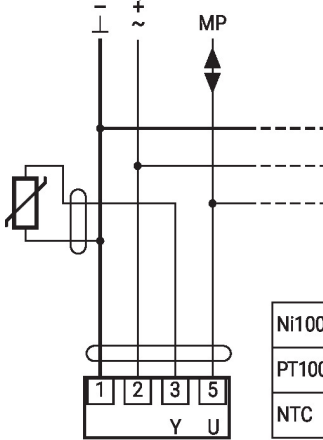

|        |                            |                             |
|--------|----------------------------|-----------------------------|
| Ni1000 | -28...+98°C                | 850...1600 Ω <sup>2)</sup>  |
| PT1000 | -35...+155°C               | 850...1600 Ω <sup>2)</sup>  |
| NTC    | -10...+160°C <sup>1)</sup> | 200 Ω...60 kΩ <sup>2)</sup> |

- 1) Depending on the type
  - 2) Resolution 1 Ohm
- Compensation of the measured value is recommended

Override control and limiting with AC 24 V with relay contacts

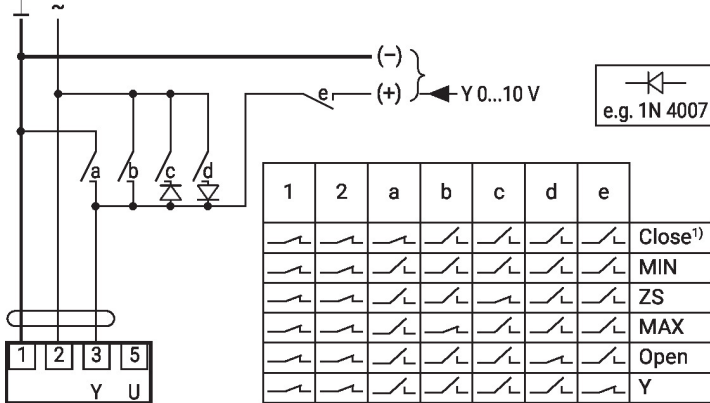

Control open/close

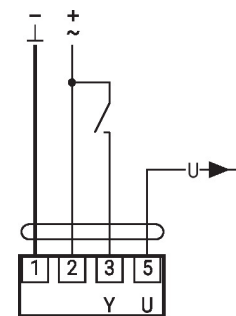

Override control and limiting with AC 24 V with rotary switch

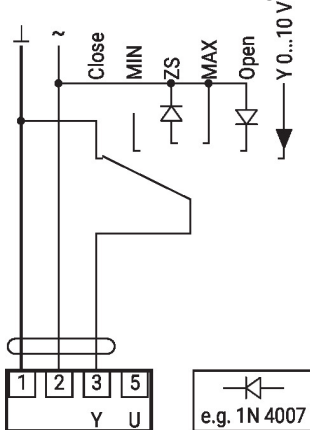

**Caution:**  
The "Close" function is only guaranteed if the start point of the operating range is defined as min. 0.5 V.

Control 3-point with AC 24 V

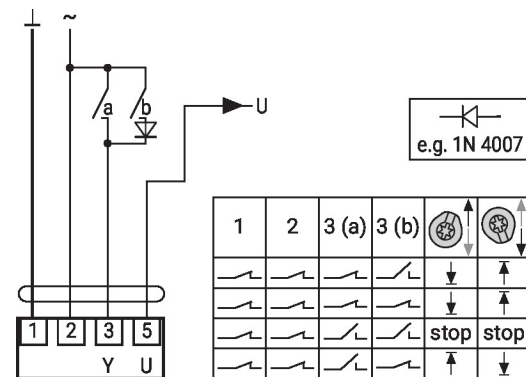

## Operating controls and indicators

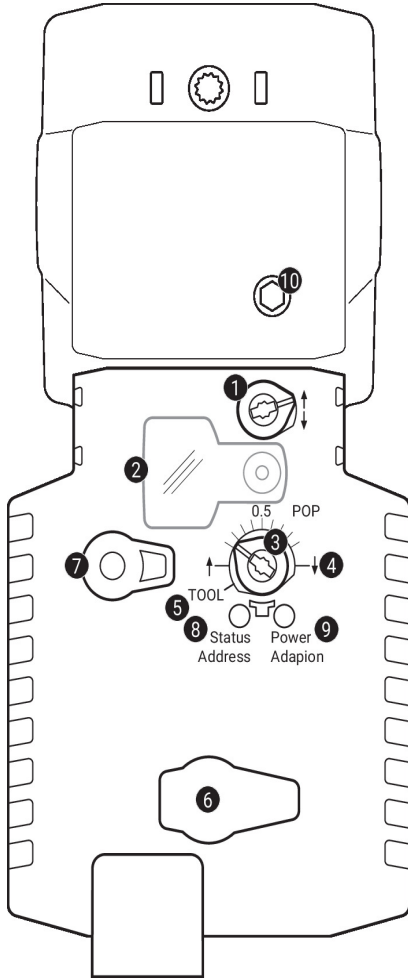
**1 Direction of stroke switch**

Switch over:                      Direction of stroke changes

**2 Cover, POP button**
**3 POP button**
**4 Scale for manual adjustment**
**5 Position for adjustment with tool**
**6 Service plug**

For connecting parametrisation and service tools

**7 Manual override button**

Press button:      Gear train disengages, motor stops, manual override possible

Release button:    Gear train engages, standard mode

**LED displays**

| yellow <b>8</b> | green <b>9</b> | Meaning / function          |
|-----------------|----------------|-----------------------------|
| Off             | On             | Operation OK                |
| Off             | Flashing       | POP function active         |
| On              | Off            | Fault                       |
| Off             | Off            | Not in operation            |
| On              | On             | Adaptation process active   |
| Flickering      | On             | MP-Bus communication active |

**8 Push-button (LED yellow)**

Press button:                      Acknowledgment of addressing

**9 Push-button (LED green)**

Press button:      Triggers stroke adaptation, followed by standard mode

**10 Manual override**

Clockwise:                              Actuator stem extends

Counterclockwise:                      Actuator stem retracts

Setting emergency setting position (POP)

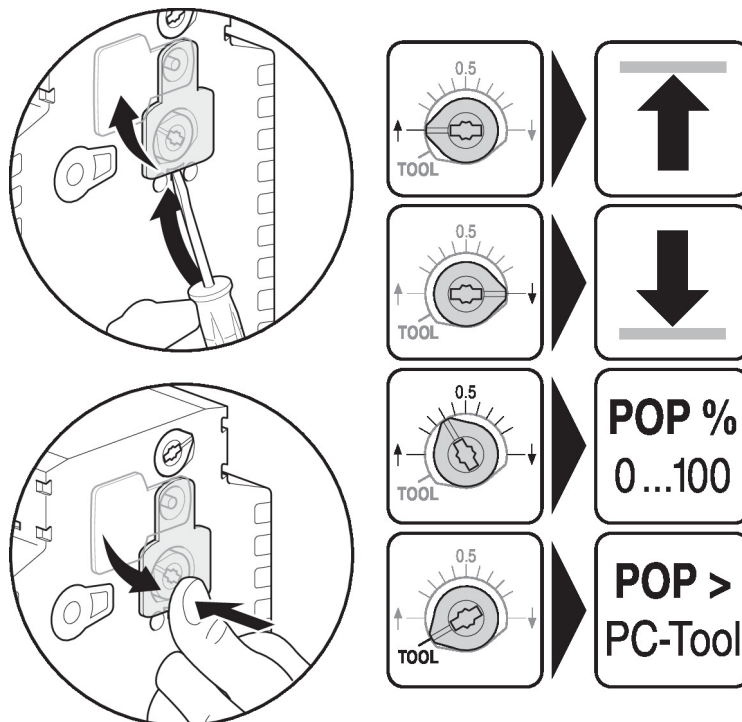

Service

**Tools connection** The actuator can be parametrised by ZTH EU via the service socket. For an extended parametrisation the PC tool can be connected.

Connection ZTH EU / PC-Tool

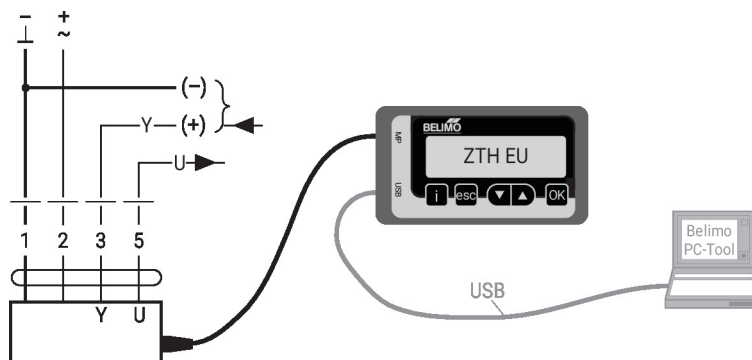

## Dimensions

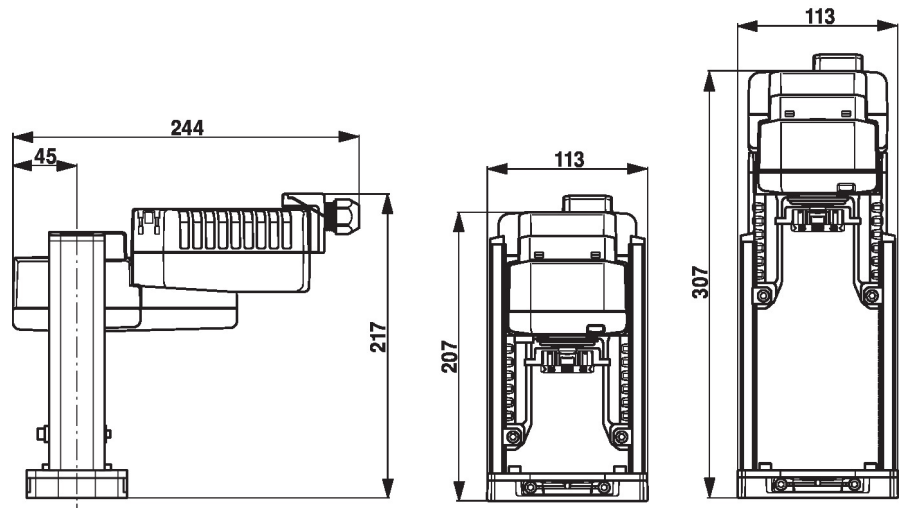

## Further documentation

- Tool connections
- Introduction to MP-Bus Technology
- Overview MP Cooperation Partners
- Data sheets for globe valves
- Installation instructions for actuators