

Communicative rotary actuator for butterfly valves

- Torque motor 400 Nm
- Nominal voltage AC/DC 24 V
- Control modulating, communicative 2...10 V variable
- Position feedback 2...10 V variable
- with 2 integrated auxiliary switches
- Conversion of sensor signals
- Communication via Belimo MP-Bus

Technical data

Electrical data	Nominal voltage	AC/DC 24 V
	Nominal voltage note	AC 24 V for 3-lead connection AC/DC 24 V for 4-lead connection
	Nominal voltage frequency	50/60 Hz
	Nominal voltage range	AC 21.6...26.4 V / DC 21.6...26.4 V
	Power consumption in operation	254 W
	Power consumption in operation note	incl. heater
	Power consumption for wire sizing	264 VA
	Current consumption	11 A
	Auxiliary switch	2 x SPDT, 1 x 3° / 1 x 87°
	Switching capacity auxiliary switch	1 mA...5 A (3 A inductive), DC 5 V...AC 250 V
	Connection supply / control	Terminals 2.5 mm ² (Wire 2 x 1.5 mm ² or 1 x 2.5 mm ²)
	Parallel operation	Yes (note the performance data)
	Data bus communication	Communicative control
Number of nodes		MP-Bus max. 8
Functional data	Torque motor	400 Nm
	Operating range Y	2...10 V
	Input Impedance	100 kΩ
	Operating range Y variable	Start point 0.5...30 V End point 2.5...32 V
	Position feedback U	2...10 V
	Position feedback U note	Max. 0.5 mA
	Position feedback U variable	Start point 0.5...8 V End point 2.5...10 V
	Position accuracy	±5%
	Manual override	temporary with handwheel (non-rotating)
	Angle of rotation	90°
	Angle of rotation note	Internal limit switch, not adjustable
	Running time motor	23 s / 90°
	Duty cycle value	75% (= active time 23 s / operating time 31 s)
	Override control	MAX (maximum position) = 100% MIN (minimum position) = 0% ZS (intermediate position, AC only) = 50%
	Sound power level, motor	70 dB(A)
	Position indication	Mechanically (integrated)
	Safety data	Protection class IEC/EN
Protection class auxiliary switch IEC/EN		I, protective earth (PE)
Degree of protection IEC/EN		IP67

Safety data	EMC	CE according to 2014/30/EU
	Low voltage directive	CE according to 2014/35/EU
	Mode of operation	Type 1
	Pollution degree	4
	Ambient humidity	Max. 95% RH, non-condensing
	Ambient temperature	-30...65°C [-22...149°F]
	Storage temperature	-30...80°C [-22...176°F]
	Servicing	maintenance-free
Mechanical data	Connection flange	F10/F12
	Weight	Weight
Materials	Housing material	Die cast aluminium

Safety notes

- This device has been designed for use in stationary heating, ventilation and air-conditioning systems and must not be used outside the specified field of application, especially in aircraft or in any other airborne means of transport.
- Only authorised specialists may carry out installation. All applicable legal or institutional installation regulations must be complied during installation.
- The device does not contain any parts that can be replaced or repaired by the user.
- The device contains electrical and electronic components and must not be disposed of as household refuse. All locally valid regulations and requirements must be observed.
- A change of the preset angle of rotation limitation may not take place neither by means of limit switches nor by means of PC-Tool/ZTH-..

Product features

Fields of application	The actuator is particularly suitable for utilisation in outdoor applications and is protected against the following weather conditions: - UV radiation - Dirt / Dust - Rain / Snow - Air humidity
Mode of operation	Conventional operation: The actuator is connected with a standard control signal and drives to the position defined by the control signal. The measuring voltage U serves for the electrical display of the actuator position 0...100% and as control signal for other actuators. Operation on Bus: The actuator receives its digital control signal from the higher level controller via the MP-Bus and drives to the position defined. Connection U serves as communication interface and does not supply an analogue measuring voltage.
Converter for sensors	Connection option for a sensor (passive or active sensor or switching contact). The MP actuator serves as an analogue/digital converter for the transmission of the sensor signal via MP-Bus to the higher level system.
Internal heating	An internal heater prevents condensation buildup.
Parametrisable actuators	The factory settings cover the most common applications. Input and output signals and other parameters can be altered with the Belimo Service Tool MFT-P.
Simple direct mounting	Simple direct mounting on the butterfly valve. The mounting orientation in relation to the butterfly valve can be selected in 90° (angle) increments.
Manual override	The butterfly valve can be closed (turn clockwise) and opened (turn counterclockwise) with the handwheel. The handwheel does not move while the motor is running.

High functional reliability

Mechanical end stops limit the actuator to -2° and 92° . The internal limit switches interrupt the voltage supply to the motor. In addition, a motor thermostat provides overload protection and interrupts the voltage supply if the actuator is used outside of the specified temperatures.

Signalling

The integrated auxiliary switches are equipped with a gold/silver coating that permits integration both in circuits with low currents (mA range) and in ones with larger-sized currents (A range) in accordance with the specifications in the data sheet. It should be noted with this application however that the contacts can no longer be used in the milliampere range after larger currents have been applied to them, even if this has taken place only once.

Accessories

Gateways	Description	Type
	Gateway MP zu BACnet MS/TP	UK24BAC
	Gateway MP to Modbus RTU	UK24MOD
Electrical accessories	Description	Type
	MP-Bus power supply for MP actuators	ZN230-24MP
Tools	Description	Type
	Service Tool, with ZIP-USB function, for parametrisable and communicative Belimo actuators, VAV controller and HVAC performance devices	ZTH EU
	Belimo PC-Tool, Software for adjustments and diagnostics	MFT-P
	Adapter for Service-Tool ZTH	MFT-C
	Connection cable 5 m, A: RJ11 6/4 ZTH EU, B: free wire end for connection to MP/PP terminal	ZK2-GEN
	Connection cable 5 m, A+B: RJ12 6/6	ZK6-GEN

Electrical installation

Supply from isolating transformer.

Maximum cable length restrictions

The maximum cable length for supply cables (in wiring diagram shown as dashes) is defined by wire cross-section.

Maximum cable lengths are in the section General Note seen!

Parallel connection of other actuators possible. Observe performance data for supply.

Wiring diagrams

Connection of active sensors

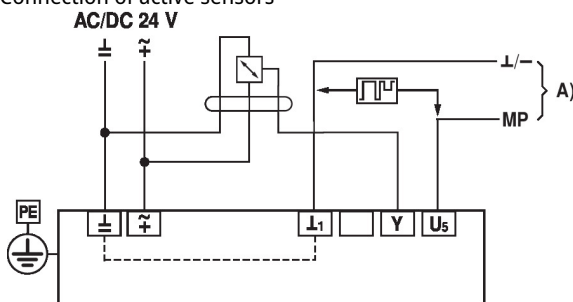

A) additional MP-Bus nodes

(max. 8)

- Supply AC / DC 24 V

- Output signal DC 0...10 V

- (max. DC 0...32 V)

- Resolution 30 mV

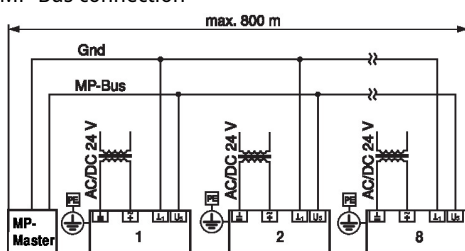
MP-Bus connection

The actuators are supplied locally with AC 24 V via a separate transformer. The cable lengths of the MP cables indicated in the table apply regardless of the performance data of the connected actuators (see general notes).

Connection of passive sensors

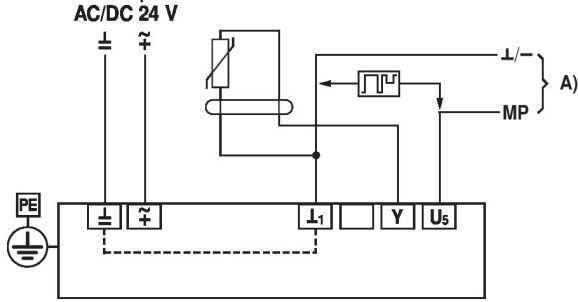

A) additional MP-Bus nodes
(max. 8)

Connection of external switching contact

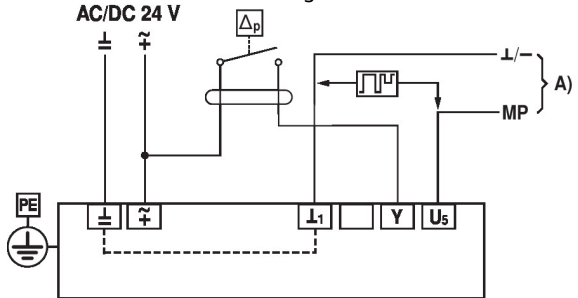

A) additional MP-Bus nodes
(max. 8)

- Switching current 16 mA @ 24 V
- Start point of the operating range must be parametrised on the MP actuator as ≥ 0.6 V

Ni1000	-28...+98 °C	850...1600 Ω	1 Ω
PT1000	-35...+155 °C	850...1600 Ω	1 Ω
NTC	-10...+160 °C	200 Ω...60 kΩ	1 Ω

3-lead connection

3-lead system connection

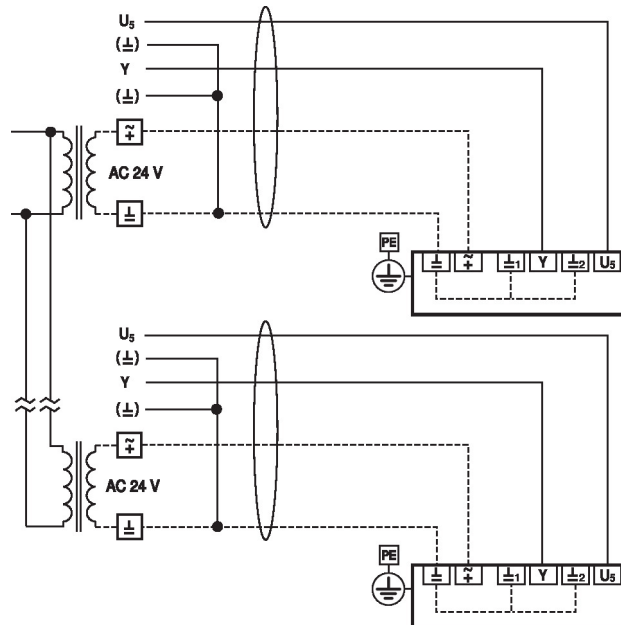

Electrical installation for 3-lead connection

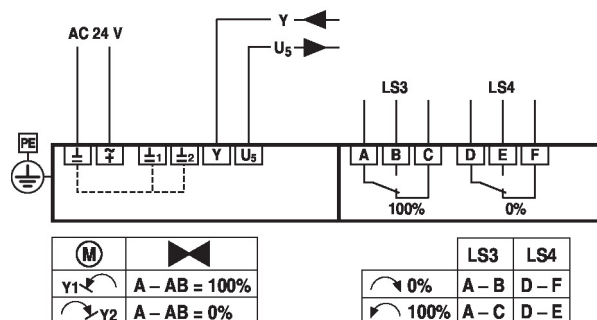

4-lead connection 4-lead system connection

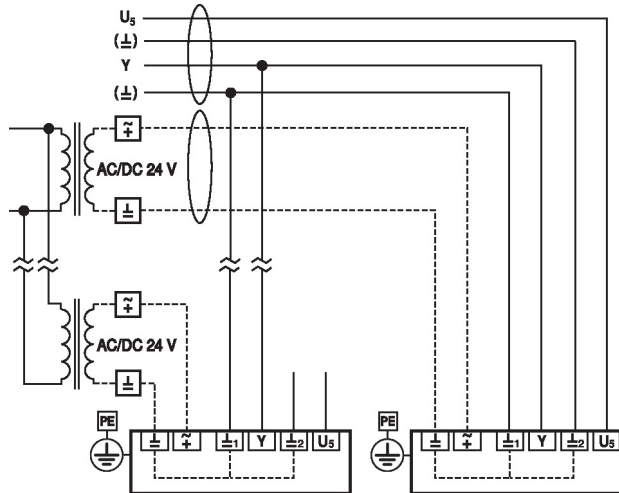

Electrical installation for 4-lead connection

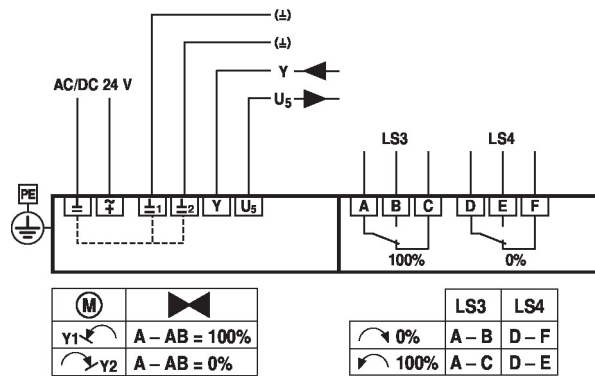

Functions



At supply interruption disconnect associated MP-Bus!

It is mandatory with DC 24 V supply that the GND signal must be connected separately on the print.

Functions when operated on MP-Bus

Connection on the MP-Bus

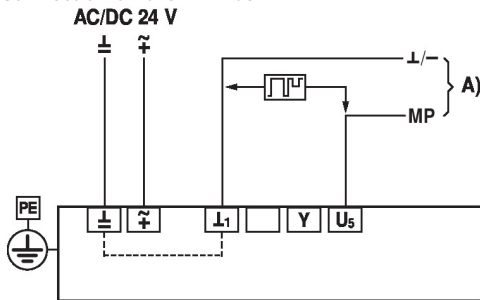

A) additional MP-Bus nodes (max. 8)

MP-Bus Network topology

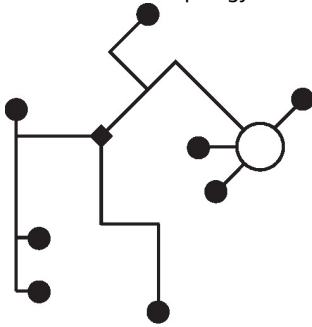

There are no restrictions for the network topology (star, ring, tree or mixed forms are permitted).

Supply and communication in one and the same 3-wire cable

- no shielding or twisting necessary
- no terminating resistors required

Functions with basic values (conventional mode)

Override control with AC 24 V with relay contacts

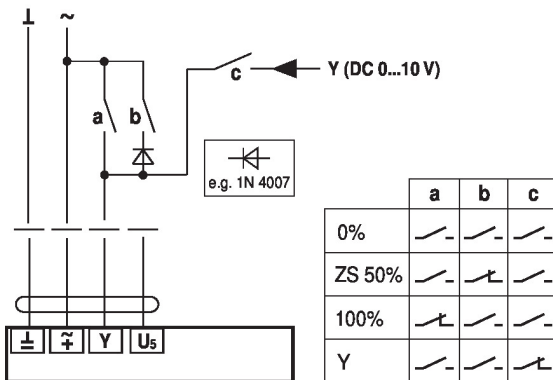

Override control with AC 24 V with rotary switch

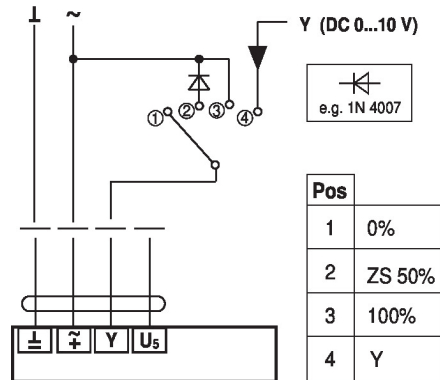

Control remotely 0...100% (with positioner)

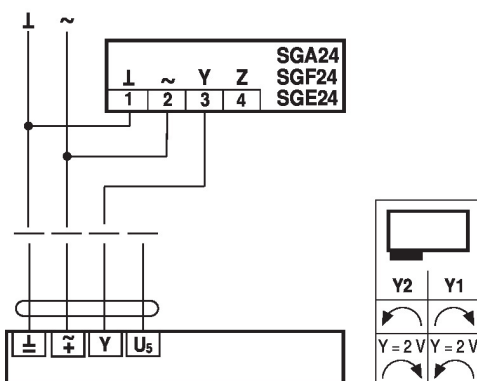

Minimum limit (with positioner)

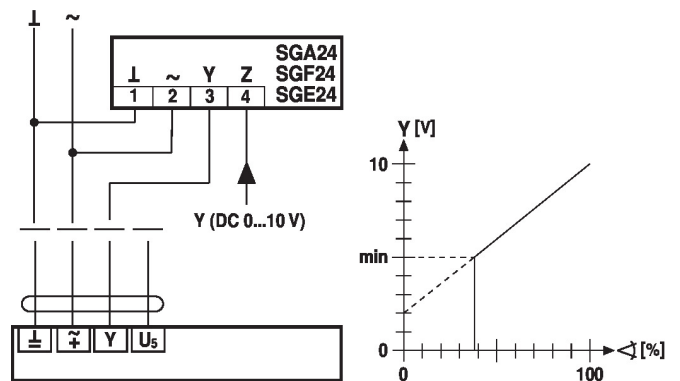

Control with 4...20 mA via external resistor

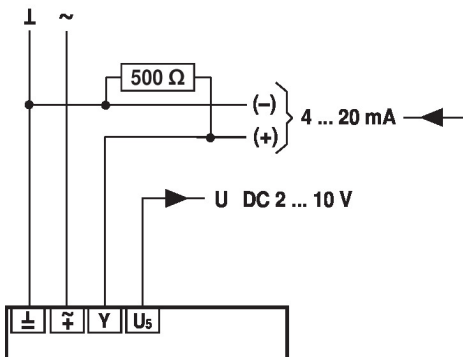

Caution:

The operating range must be set to DC 2...10 V.

The 500 Ω resistor converts the 4...20 mA current signal to a voltage signal DC 2...10 V

Functions with specific parameters (parametrisation necessary)

Control open/close

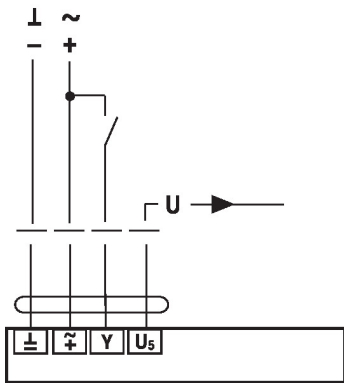

Control 3-point

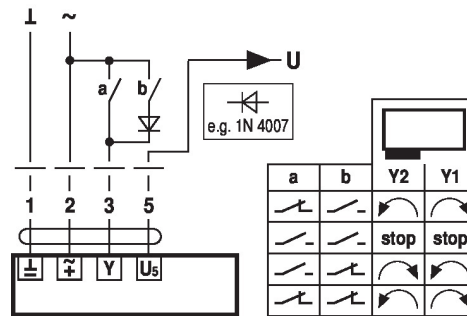

Connection and function elements

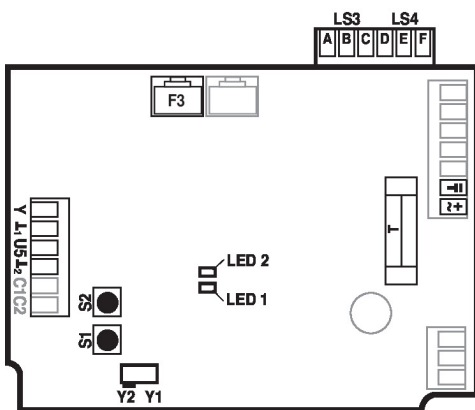

$\underline{\quad} / \sim$	Power supply voltage	
Y1	Direction of rotation switch	Actuator rotates anticlockwise (ccw), valve opens
Y2	Direction of rotation switch	Actuator rotates clockwise (cw) valve closes
Y	Control signal	
U5	Position feedback	
$\underline{\quad}_1 / \underline{\quad}_2$	0-lead (ground)	
F3	PC-tool connection	
S1	Adaptation button	Adaptation procedure is started (press S1 for 3 s) Adaptation must take place after the TC1/TC2 have been adjusted
S2	Addressing button	Addressing procedure is started (press S2 for 3 s)
LED 1 (yellow)	On	Adaptation procedure activated
	Off	Standard operation
LED 2 (green)	On	In operation
	Off	No voltage supply or fault
T	Plug-in fuse	Type T10A250V
LS3	Auxiliary switch	Factory setting 87°
LS4	Auxiliary switch	Factory setting 3°
C1 / C2	Not used	

Settings



Limit switches TC1/TC2 and angle of rotation limitation are provided with sealing varnish and may not be adjusted.

Setting cam

The setting cams for limit and auxiliary switches can be accessed by removing the housing cover.

Optionally, auxiliary switches LS4 / LS3 can be connected for signalling.

Limit switches LS2 / LS1 interrupt the voltage to the motor and are controlled by setting cams TC...

The setting cams turn with the spindle. The butterfly valve closes when the spindle is turning clockwise (cw) and opens when the spindle is turning counterclockwise (ccw).

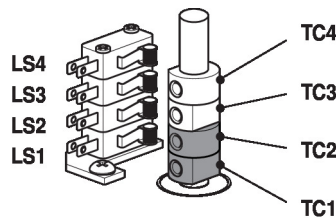

TC1/TC2 with sealing varnish: limit switches are secured against adjustment

Settings of setting cams TC..

- TC4 for auxiliary switch position closed (factory setting 3°).
- TC3 for auxiliary switch position open (factory setting 87°).
- TC2 for limit switch closed (0°).
- TC1 for limit switch open (90°).

Adjusting setting cams

- 1) Use a 2.5 mm Allen key to unscrew the corresponding setting cams TC..
- 2) Turn the setting cam using the Allen key
- 3) Set as shown in the illustration below
- 4) Use the Allen key to tighten the corresponding setting cams

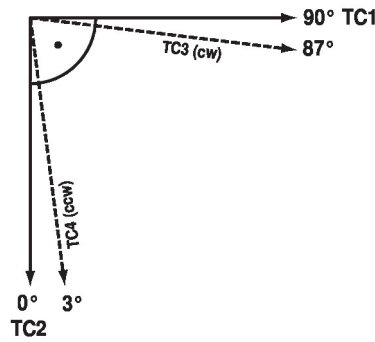

TC1: OPEN
 TC2: CLOSED
 TC3: Present position
 TC4: Desired position

Mechanical angle-of-rotation limitation

The mechanical angle of rotation (3) is set at the factory to -2° and 92° and cannot be changed. The handwheel is rotated by means of a worm gear in a planetary gear unit. The gearing is stopped mechanically by means of two setscrews (3).

Relationship between mechanical angle of rotation limitation, limit and auxiliary switches

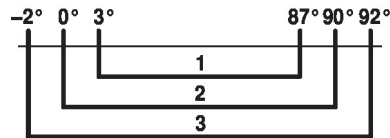

- 1: Auxiliary switch adjustable TC3 / TC4
- 2: Limit switch fix adjusted TC1 / TC2
- 3: Mechanical angle of rotation fix adjusted

- 3: Angle of rotation limitation with sealing varnish: Must not be adjusted
- 4: Connection handwheel

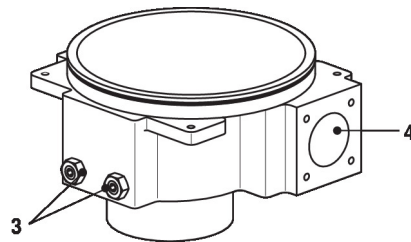

Service

Notes

Actuators may be configured with Belimo PC-Tool MFT-P or ZTH EU service tool using the service socket of the actuator.



Tools connection Local connection with ZTH EU via service socket of the SY actuator.

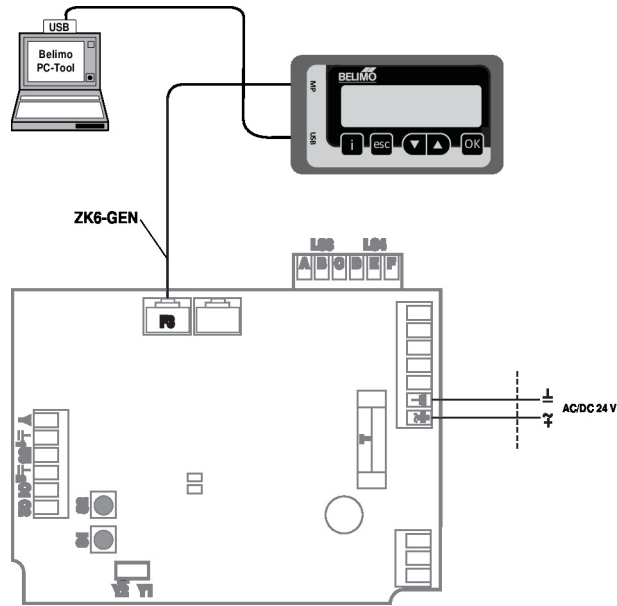

Note
The housing cover must be opened in order to access the connections.
Please note!
It is mandatory with 24 V supply that the GND signal be guided separately on the print.

Dimensions

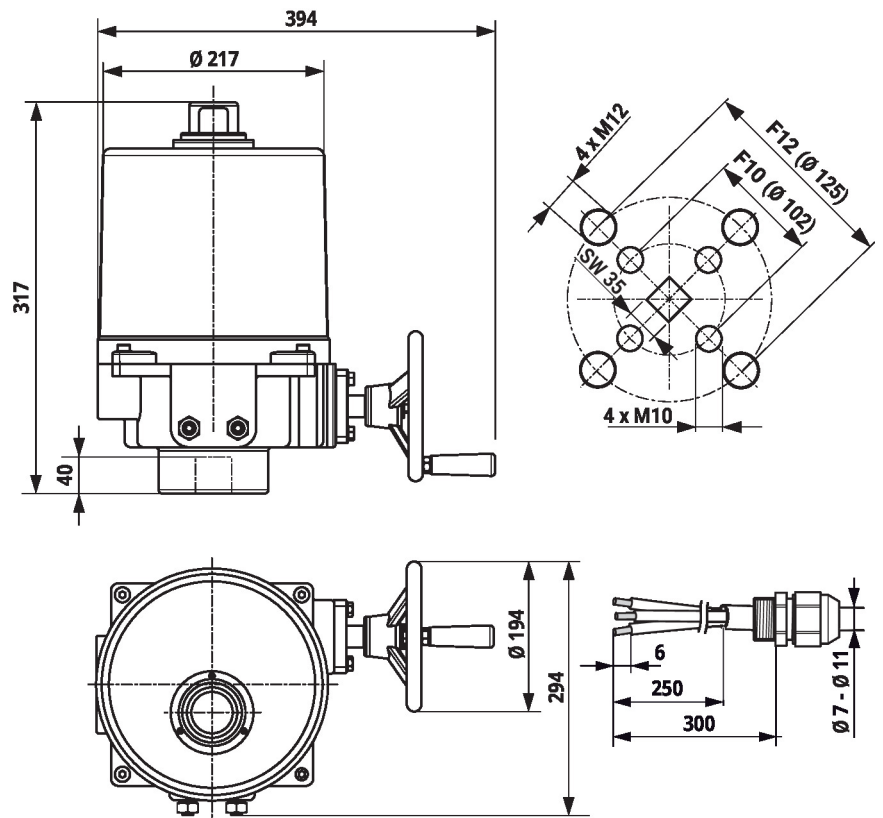

Further documentation

- Overview MP Cooperation Partners
- Tool connections
- Introduction to MP-Bus Technology
- Data sheets for butterfly valves
- Installation instructions for actuators and/or butterfly valves
- Notes for project planning for butterfly valves