

Communicative rotary actuator for ball valves

- Torque motor 5 Nm
- Nominal voltage AC/DC 24 V
- Control modulating, communicative 2...10 V variable
- Position feedback 2...10 V variable
- Communication via Belimo MP-Bus
- Conversion of sensor signals



## Technical data

<b>Electrical data</b>	Nominal voltage	AC/DC 24 V
	Nominal voltage frequency	50/60 Hz
	Nominal voltage range	AC 19.2...28.8 V / DC 21.6...28.8 V
	Power consumption in operation	2.5 W
	Power consumption in rest position	1.3 W
	Power consumption for wire sizing	5 VA
	Connection supply / control	Cable 1 m, 4 x 0.75 mm <sup>2</sup>
	Parallel operation	Yes (note the performance data)
<b>Data bus communication</b>	Communicative control	MP-Bus
	Number of nodes	MP-Bus max. 8
<b>Functional data</b>	Torque motor	5 Nm
	Operating range Y	2...10 V
	Input impedance	100 kΩ
	Operating range Y variable	Start point 0.5...30 V End point 2.5...32 V
	Operating modes optional	Open/close 3-point (AC only) Modulating (DC 0...32 V)
	Position feedback U	2...10 V
	Position feedback U note	Max. 0.5 mA
	Position feedback U variable	Start point 0.5...8 V End point 2.5...10 V
	Position accuracy	±5%
	Manual override	with push-button, can be locked
	Running time motor	90 s / 90°
	Running time motor variable	35...150 s
	Adaptation setting range	manual (automatic on first power-up)
	Adaptation setting range variable	No action Adaptation when switched on Adaptation after pushing the manual override button
	Override control	MAX (maximum position) = 100% MIN (minimum position) = 0% ZS (intermediate position, AC only) = 50%
	Override control variable	MAX = (MIN + 33%)...100% MIN = 0%...(MAX - 33%) ZS = MIN...MAX
	Sound power level, motor	35 dB(A)
Position indication	Mechanical, pluggable	
<b>Safety data</b>	Protection class IEC/EN	III, Safety Extra-Low Voltage (SELV)

<b>Safety data</b>	Power source UL	Class 2 Supply
	Degree of protection IEC/EN	IP54
	Degree of protection NEMA/UL	NEMA 2
	Enclosure	UL Enclosure Type 2
	EMC	CE according to 2014/30/EU
	Certification IEC/EN	IEC/EN 60730-1 and IEC/EN 60730-2-14
	UL Approval	cULus according to UL60730-1A, UL60730-2-14 and CAN/CSA E60730-1 The UL marking on the actuator depends on the production site, the device is UL-compliant in any case
	Type of action	Type 1
	Rated impulse voltage supply / control	0.8 kV
	Pollution degree	3
	Ambient humidity	Max. 95% RH, non-condensing
	Ambient temperature	-30...50°C [-22...122°F]
	Storage temperature	-40...80°C [-40...176°F]
	Servicing	maintenance-free
	<b>Weight</b>	Weight

**Safety notes**

- This device has been designed for use in stationary heating, ventilation and air-conditioning systems and must not be used outside the specified field of application, especially in aircraft or in any other airborne means of transport.
- Outdoor application: only possible in case that no (sea) water, snow, ice, insulation or aggressive gases interfere directly with the device and that it is ensured that the ambient conditions remain within the thresholds according to the data sheet at any time.
- Only authorised specialists may carry out installation. All applicable legal or institutional installation regulations must be complied during installation.
- The switch for changing the direction of rotation may only be operated by authorised specialists. The direction of rotation must not in particular be reversed in a frost protection circuit.
- The device may only be opened at the manufacturer's site. It does not contain any parts that can be replaced or repaired by the user.
- Cables must not be removed from the device.
- The device contains electrical and electronic components and must not be disposed of as household refuse. All locally valid regulations and requirements must be observed.

**Product features**

<b>Mode of operation</b>	<p>Conventional operation:</p> <p>The actuator is connected with a standard control signal of 0...10 V and drives to the position defined by the control signal. The measuring voltage U serves for the electrical display of the actuator position 0.5...100% and as control signal for other actuators.</p> <p>Operation on Bus:</p> <p>The actuator receives its digital control signal from the higher level controller via the MP-Bus and drives to the position defined. Connection U serves as communication interface and does not supply an analogue measuring voltage.</p>
<b>Converter for sensors</b>	<p>Connection option for a sensor (passive or active sensor or switching contact). The MP actuator serves as an analogue/digital converter for the transmission of the sensor signal via MP-Bus to the higher level system.</p>
<b>Parametrisable actuators</b>	<p>The factory settings cover the most common applications. Single parameters can be modified with the Belimo Service Tools MFT-P or ZTH EU.</p>

<b>Simple direct mounting</b>	Straightforward direct mounting on the ball valve with only one central screw. The assembly tool is integrated in the plug-in position indication. The mounting orientation in relation to the ball valve can be selected in 90° steps.
<b>Manual override</b>	Manual override with push-button possible (the gear train is disengaged for as long as the button is pressed or remains locked).
<b>Adjustable angle of rotation</b>	Adjustable angle of rotation with mechanical end stops.
<b>High functional reliability</b>	The actuator is overload protected, requires no limit switches and automatically stops when the end stop is reached.
<b>Home position</b>	<p>The first time the supply voltage is switched on, i.e. at the time of commissioning, the actuator carries out an adaptation, which is when the operating range and position feedback adjust themselves to the mechanical setting range.</p> <p>The actuator then moves into the position defined by the control signal.</p> <p>Factory setting: Y2 (counter-clockwise rotation).</p>
<b>Adaptation and synchronisation</b>	<p>An adaptation can be triggered manually by pressing the "Adaptation" button or with the PC-Tool. Both mechanical end stops are detected during the adaptation (entire setting range).</p> <p>Automatic synchronisation after pressing the manual override button is configured. The synchronisation is in the home position (0%).</p> <p>The actuator then moves into the position defined by the control signal.</p> <p>A range of settings can be adapted using the PC-Tool (see MFT-P documentation)</p>

**Accessories**

<b>Gateways</b>	<b>Description</b>	<b>Type</b>
	Gateway MP to BACnet MS/TP	UK24BAC
	Gateway MP to Modbus RTU	UK24MOD
<b>Electrical accessories</b>	<b>Description</b>	<b>Type</b>
	Auxiliary switch 1 x SPDT add-on	S1A
	Auxiliary switch 2 x SPDT add-on	S2A
	Feedback potentiometer 140 Ω add-on	P140A
	Feedback potentiometer 200 Ω add-on	P200A
	Feedback potentiometer 500 Ω add-on	P500A
	Feedback potentiometer 1 kΩ add-on	P1000A
	Feedback potentiometer 2.8 kΩ add-on	P2800A
	Feedback potentiometer 5 kΩ add-on	P5000A
	Feedback potentiometer 10 kΩ add-on	P10000A
	MP-Bus power supply for MP actuators	ZN230-24MP
	Room temperature controller with 3 sequences	CR24-A3
	Room temperature controller with 3 sequences	CR24-B3
	Room temperature controller	CRK24-B1
<b>Tools</b>	<b>Description</b>	<b>Type</b>
	Service Tool, with ZIP-USB function, for parametrisable and communicative Belimo actuators, VAV controller and HVAC performance devices	ZTH EU
	Belimo PC-Tool, Software for adjustments and diagnostics	MFT-P
	Adapter for Service-Tool ZTH	MFT-C
	Connecting cable 5 m, A: RJ11 6/4 ZTH EU, B: 6-pin for connection to service socket	ZK1-GEN
	Connecting cable 5 m, A: RJ11 6/4 ZTH EU, B: free wire end for connection to MP/PP terminal	ZK2-GEN

**Electrical installation**

**Supply from isolating transformer.**

**Parallel connection of other actuators possible. Observe the performance data.**

**Direction of rotation switch is covered. Factory setting: Direction of rotation Y2.**

**Wire colours:**

- 1 = black
- 2 = red
- 3 = white
- 5 = orange

**Wiring diagrams**

Operation on the MP-Bus

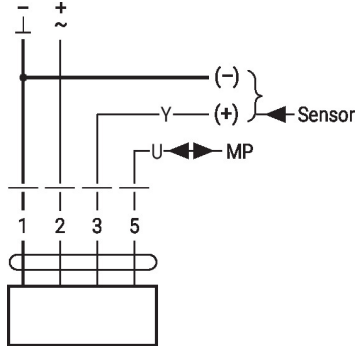

AC/DC 24 V, modulating

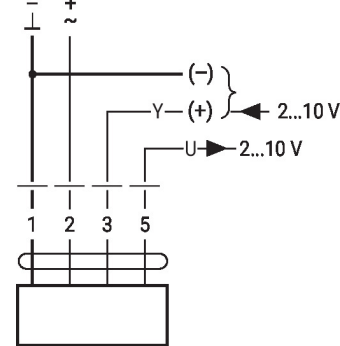

1	2	3	
		2 V	A - AB = 0%
		10 V	A - AB = 100%

**Functions**

**Functions with basic values (conventional mode)**

Override control with AC 24 V with relay contacts

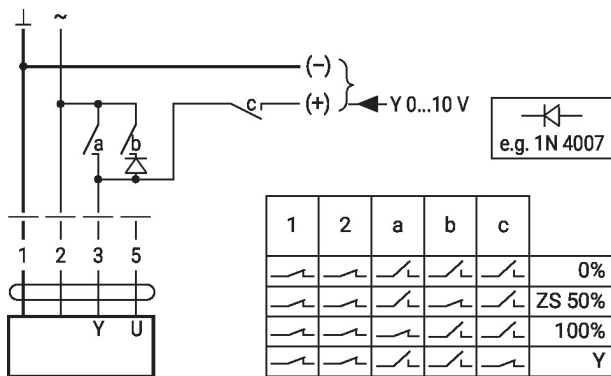

Override control with AC 24 V with rotary switch

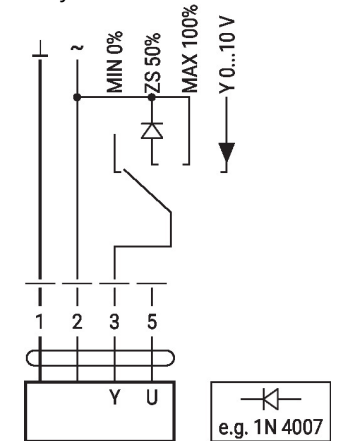

Control remotely 0...100% with positioner SG..

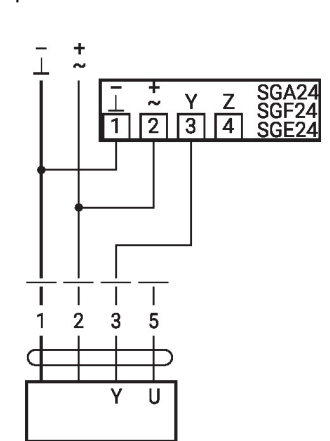

Minimum limit with positioner SG..

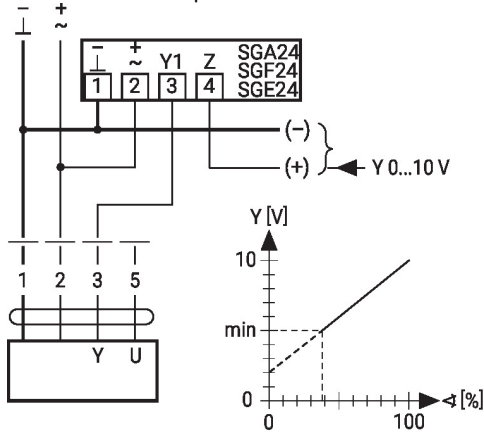

Primary/secondary operation (position-dependent)

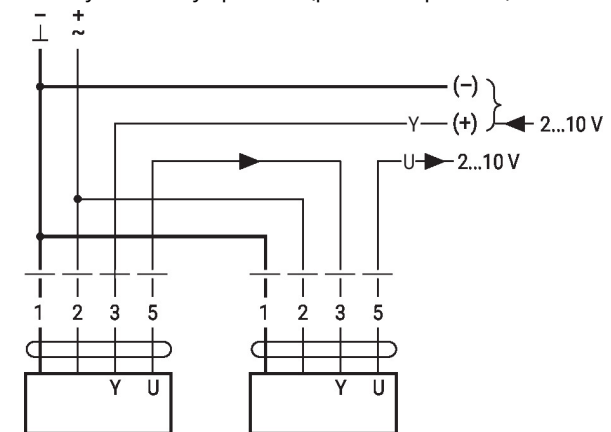

Control with 4...20 mA via external resistor

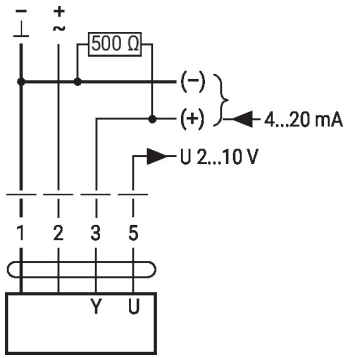

**Caution:**  
The operating range must be set to DC 2...10 V.  
The 500 Ohm resistor converts the 4...20 mA current signal to a voltage signal DC 2...10 V.

Functional check

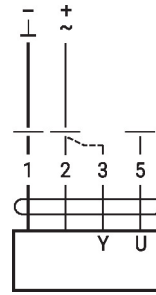

**Procedure**

1. Connect 24 V to connections 1 and 2
2. Disconnect connection 3:
  - with direction of rotation L: Actuator rotates to the left
  - with direction of rotation R: Actuator rotates to the right
3. Short-circuit connections 2 and 3:
  - Actuator runs in opposite direction

Functions with specific parameters (Parametrisation necessary)

Connection on the MP-Bus

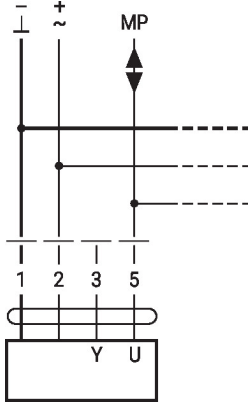

Max. 8 additional MP-Bus nodes

MP-Bus Network topology

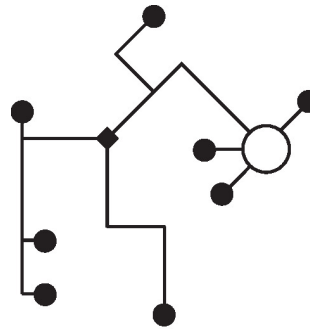

There are no restrictions for the network topology (star, ring, tree or mixed forms are permitted).  
Supply and communication in one and the same 3-wire cable

- no shielding or twisting necessary
- no terminating resistors required

Connection of active sensors

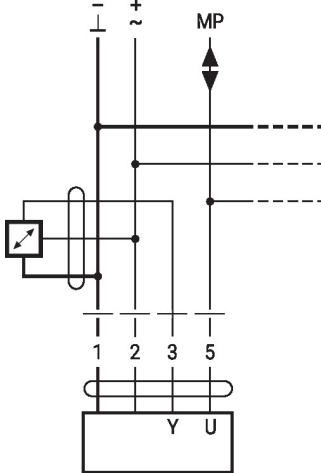

- Max. 8 additional MP-Bus nodes
- Supply AC/DC 24 V
  - Output signal 0...10 V (max. 0...32 V)
  - Resolution 30 mV

Connection of external switching contact

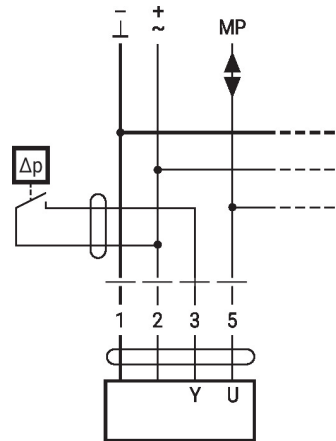

- Max. 8 additional MP-Bus nodes
- Switching current 16 mA @ 24 V
  - Start point of the operating range must be parametrised on the MP actuator as  $\geq 0.5$  V

Connection of passive sensors

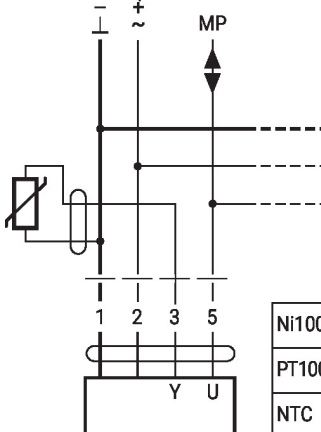

Ni1000	-28...+98°C	850...1600 $\Omega$ <sup>2)</sup>
PT1000	-35...+155°C	850...1600 $\Omega$ <sup>2)</sup>
NTC	-10...+160°C <sup>1)</sup>	200 $\Omega$ ...60 k $\Omega$ <sup>2)</sup>

1) Depending on the type  
2) Resolution 1 Ohm  
Compensation of the measured value is recommended

Override control and limiting with AC 24 V with relay contacts

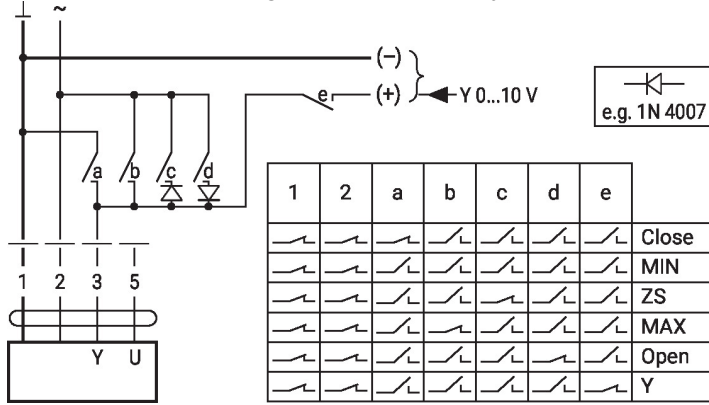

Control open/close

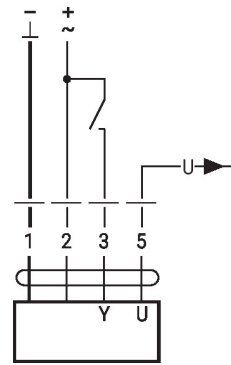

Override control and limiting with AC 24 V with rotary switch

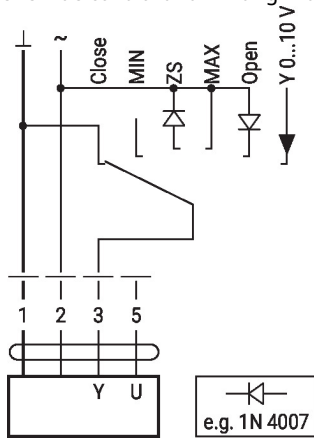

**Caution:**  
The "Close" function is only guaranteed if the start point of the operating range is defined as min. 0.5 V.

Control 3-point with AC 24 V

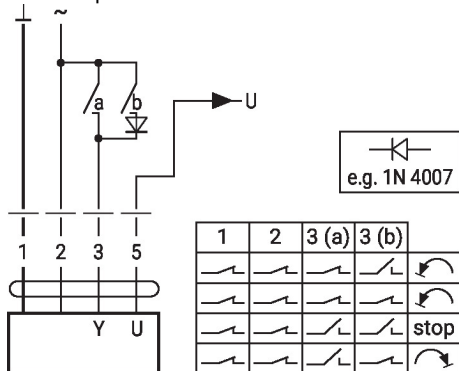

Position control: 90° = 100s  
Flow control: Vmax = 100s

Operating controls and indicators

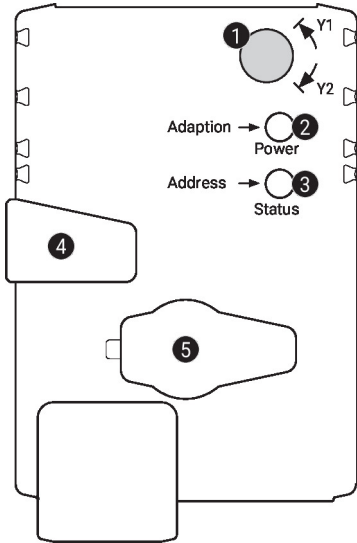

**1 Direction of rotation switch**

Switch over: Direction of rotation changes

**2 Push-button and LED display green**

Off: No power supply or malfunction  
 On: In operation  
 Press: Triggers angle of rotation adaptation, followed by standard mode button:

**3 Push-button and LED display yellow**

Off: Standard mode  
 On: Adaptation or synchronisation process active  
 Flickering: MP-Bus communication active  
 Flashing: Request for addressing from MP client  
 Press button: Confirmation of the addressing

**4 Manual override button**

Press button: Gear train disengages, motor stops, manual override possible  
 Release button: Gear train engages, standard mode

**5 Service plug**

For connecting parametrisation and service tools

**Check power supply connection**

**2** Off and **3** On Possible wiring error in power supply

Service

**Tools connection** The actuator can be parametrised by ZTH EU via the service socket. For an extended parametrisation the PC tool can be connected.

Connection ZTH EU / PC-Tool

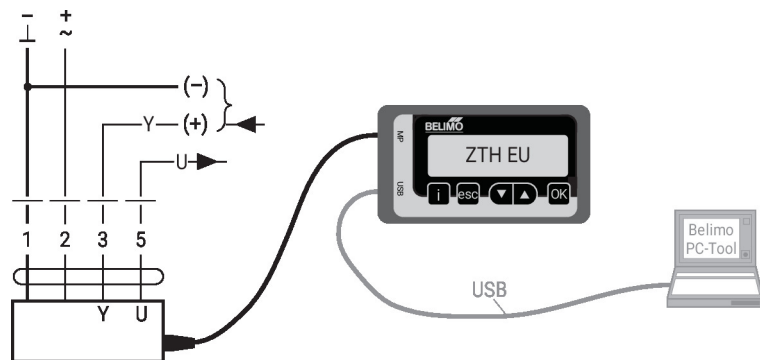

## Dimensions

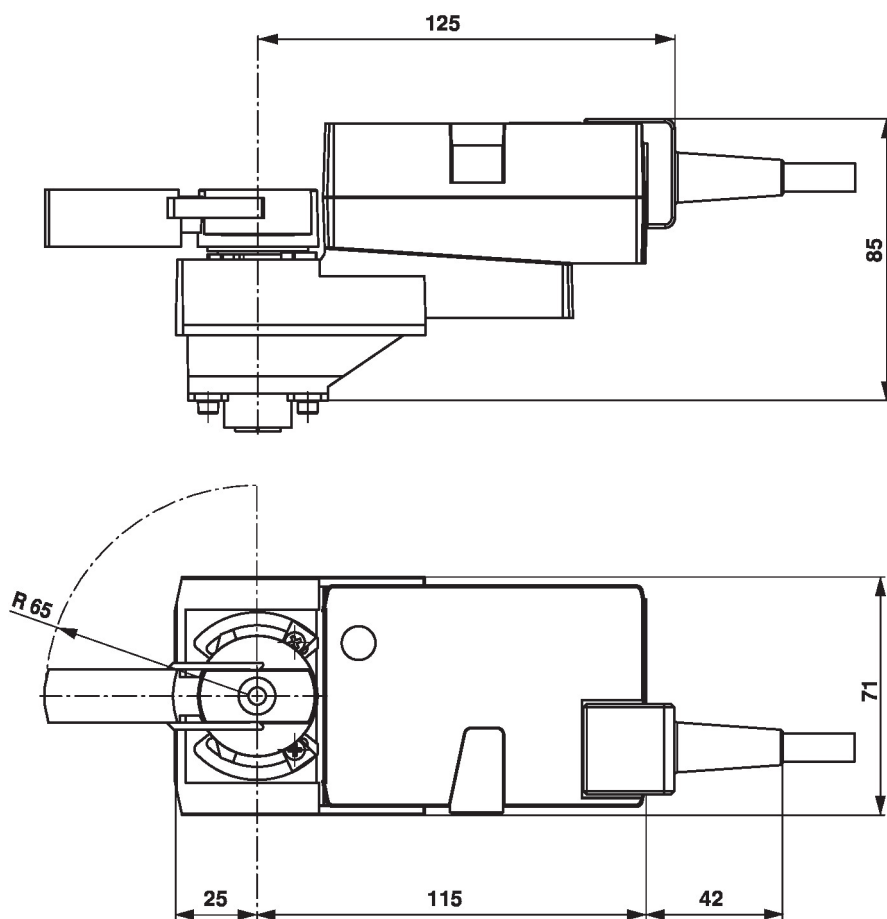

## Further documentation

- Overview MP Cooperation Partners
- Tool connections
- Introduction to MP-Bus Technology
- The complete product range for water applications
- Data sheets for ball valves
- Installation instructions for actuators and/or ball valves
- General notes for project planning