

Communicative globe valve actuator with fail-safe for 2-way and 3-way globe valves

- Actuating force 2000 N
- Nominal voltage AC/DC 24 V
- Control modulating, communicative, hybrid
- Stroke 32 mm
- Communication via BACnet MS/TP, Modbus RTU, Belimo-MP-Bus or conventional control
- Conversion of sensor signals

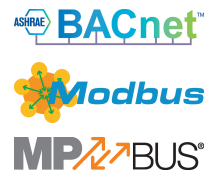

Technical data

<b>Electrical data</b>	Nominal voltage	AC/DC 24 V
	Nominal voltage frequency	50/60 Hz
	Nominal voltage range	AC 19.2...28.8 V / DC 21.6...28.8 V
	Power consumption in operation	5 W
	Power consumption in rest position	2 W
	Power consumption for wire sizing	9.5 VA
	Connection supply / control	Cable 1 m, 6 x 0.75 mm <sup>2</sup>
<b>Data bus communication</b>	Communicative control	BACnet MS/TP Modbus RTU (default setting) MP-Bus
	Number of nodes	BACnet / Modbus see interface description MP-Bus max. 8
<b>Functional data</b>	Actuating force motor	2000 N
	Operating range Y	2...10 V
	Operating range Y variable	0.5...10 V
	Position feedback U	2...10 V
	Position feedback U note	Max. 0.5 mA
	Position feedback U variable	Start point 0.5...8 V End point 2...10 V
	Setting fail-safe position	Stem 0...100%, adjustable (POP rotary knob)
	Bridging time (PF)	2 s
	Bridging time (PF) variable	0...10 s
	Position accuracy	±5%
	Manual override	with push-button
	Stroke	32 mm
	Running time motor	150 s / 32 mm
	Running time motor variable	90...150 s
	Running time fail-safe	35 s / 32 mm
	Adaptation setting range	manual (automatic on first power-up)
	Adaptation setting range variable	No action Adaptation when switched on Adaptation after pushing the manual override button
	Override control, controllable via bus communication	MAX (maximum position) = 100% MIN (minimum position) = 0% ZS (intermediate position) = 50%
	Override control variable	MAX = (MIN + 33%)...100% ZS = MIN...MAX
	Sound power level, motor	60 dB(A)
Sound power level, fail-safe	60 dB(A)	
Position indication	Mechanical, 5...32 mm stroke	

<b>Safety data</b>	Protection class IEC/EN	III, Safety Extra-Low Voltage (SELV)
	Power source UL	Class 2 Supply
	Degree of protection IEC/EN	IP54
	Degree of protection NEMA/UL	NEMA 2
	Enclosure	UL Enclosure Type 2
	EMC	CE according to 2014/30/EU
	Certification IEC/EN	IEC/EN 60730-1 and IEC/EN 60730-2-14
	UL Approval	cULus according to UL60730-1A, UL60730-2-14 and CAN/CSA E60730-1 The UL marking on the actuator depends on the production site, the device is UL-compliant in any case
	Type of action	Type 1.AA
	Rated impulse voltage supply / control	0.8 kV
	Pollution degree	3
	Ambient humidity	Max. 95% RH, non-condensing
	Ambient temperature	0...50°C [32...122°F]
	Storage temperature	-40...80°C [-40...176°F]
	Servicing	maintenance-free
<b>Weight</b>	Weight	4.6 kg
<b>Terms</b>	Abbreviations	POP = Power off position / fail-safe position CPO = Controlled power off / controlled fail-safe PF = Power fail delay time / bridging time

**Safety notes**

- This device has been designed for use in stationary heating, ventilation and air-conditioning systems and must not be used outside the specified field of application, especially in aircraft or in any other airborne means of transport.
- Outdoor application: only possible in case that no (sea) water, snow, ice, insulation or aggressive gases interfere directly with the device and that it is ensured that the ambient conditions remain within the thresholds according to the data sheet at any time.
- Only authorised specialists may carry out installation. All applicable legal or institutional installation regulations must be complied during installation.
- The switch for changing the direction of motion and so the closing point may be adjusted only by authorised specialists. The direction of motion is critical, particularly in connection with frost protection circuits.
- The device may only be opened at the manufacturer's site. It does not contain any parts that can be replaced or repaired by the user.
- Cables must not be removed from the device.
- The device contains electrical and electronic components and must not be disposed of as household refuse. All locally valid regulations and requirements must be observed.

**Product features**

**Mode of operation** The actuator is fitted with an integrated interface for BACnet MS/TP, Modbus RTU and MP-Bus. It receives the digital control signal from the control system and returns the current status. Interrupting the supply voltage causes the valve to be moved to the selected fail-safe position by means of stored electrical energy.

**Pre-charging time (start up)**

The capacitor actuators require a pre-charging time. This time is used for charging the capacitors up to a usable voltage level. This ensures that, in the event of a power failure, the actuator can move at any time from its current position into the preset fail-safe position.

The duration of the pre-charging time depends mainly on following factors:

- Duration of the power failure
- PF delay time (bridging time)

Typical pre-charging time

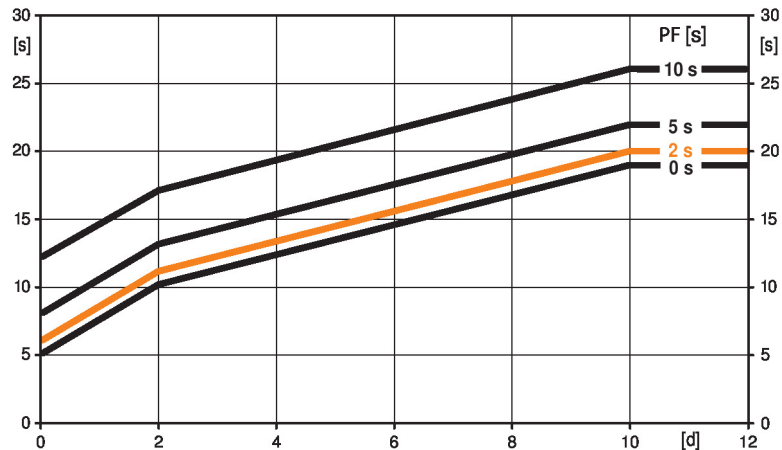

[d] = Power failure in days

[s] = Pre-charging time in seconds

PF[s] = Bridging time

Calculation example: Given a power failure of 3 days and a bridging time (PF) set at 5 s, the actuator requires a pre-charging time of 14 s after the power has been reconnected (see graphic).

PF [s]	[d]				
	0	1	2	7	≥10
0	5	8	10	15	19
2	6	9	11	16	20
5	8	11	13	18	22
10	12	15	17	22	26
	[s]				

**Delivery condition (capacitors)**

The actuator is completely discharged after delivery from the factory, which is why the actuator requires approximately 20 s pre-charging time before initial commissioning in order to bring the capacitors up to the required voltage level.

**Bridging time**

Power failures can be bridged up to a maximum of 10 s.

In the event of a power failure, the actuator will remain stationary in accordance with the set bridging time. If the power failure is greater than the set bridging time, the actuator will move into the selected fail-safe position.

The bridging time set at the factory is 2 s. It can be modified on site in operation by means of the Belimo service tool MFT-P.

Settings: The rotary knob must not be set to the "Tool" position!

For retroactive adjustments of the bridging time with the Belimo service tool MFT-P or with the ZTH EU adjustment and diagnostic device only the values need to be entered.

**Setting fail-safe position (POP)**

The rotary knob fail-safe position can be used to adjust the desired fail-safe position from 0...100% in 10% increments. The rotary knob refers to the adapted or programmed height of stroke. In the event of a power failure, the actuator will move to the selected fail-safe position, taking into account the bridging time (PF) of 2 s set at the factory.

Settings: The rotary knob must be set to the «Tool» position for retroactive settings of the fail-safe position with the Belimo service tool MFT-P. Once the rotary knob is set back to the range 0...100%, the manually set value will have positioning authority.

**Converter for sensors**

Connection option for a sensor (passive, active or with switching contact). In this way, the analogue sensor signal can be easily digitised and transferred to the bus systems : BACnet, Modbus or MP-Bus.

<b>Parametrisable actuators</b>	<p>The factory settings cover the most common applications. Single parameters can be modified with the Belimo Service Tools MFT-P or ZTH EU.</p> <p>The communication parameters of the bus systems (address, baud rate etc.) are set with the ZTH EU. Pressing the "Address" button on the actuator while connecting the supply voltage, resets the communication parameters to the factory setting.</p> <p>Quick addressing: The BACnet and Modbus address can alternatively be set using the buttons on the actuator and selecting 1...16. The value selected is added to the «Basic address» parameter and results in the effective BACnet and Modbus address.</p>
<b>Combination analogue - communicative (hybrid mode)</b>	<p>With conventional control by means of an analogue control signal, BACnet or Modbus can be used for the communicative position feedback</p>
<b>Simple direct mounting</b>	<p>Simple direct mounting on the globe valve by means of form-fit hollow clamping jaws. The actuator can be rotated by 360° on the valve neck.</p>
<b>Manual override</b>	<p>Manual control with push-button possible - temporary. The gear train is disengaged and the actuator decoupled for as long as the button is pressed.</p> <p>The stroke can be adjusted by using a hexagon socket screw key (5 mm), which is inserted into the top of the actuator. The stem extends when the key is rotated clockwise.</p>
<b>High functional reliability</b>	<p>The actuator is overload protected, requires no limit switches and automatically stops when the end stop is reached.</p>
<b>Home position</b>	<p>Factory setting: Actuator stem is retracted.</p> <p>When valve-actuator combinations are shipped, the direction of motion is set in accordance with the closing point of the valve.</p> <p>The first time the supply voltage is switched on, i.e. at the time of commissioning, the actuator carries out an adaptation, which is when the operating range and position feedback adjust themselves to the mechanical setting range.</p> <p>The actuator then moves into the position defined by the control signal.</p>
<b>Adaptation and synchronisation</b>	<p>An adaptation can be triggered manually by pressing the "Adaptation" button or with the PC-Tool. Both mechanical end stops are detected during the adaptation (entire setting range).</p> <p>Automatic synchronisation after pressing the manual override button is configured. The synchronisation is in the home position (0%).</p> <p>The actuator then moves into the position defined by the control signal.</p> <p>A range of settings can be adapted using the PC-Tool (see MFT-P documentation)</p>
<b>Setting direction of motion</b>	<p>When actuated, the stroke direction switch changes the running direction in normal operation. The stroke direction switch has no influence on the fail-safe position which has been set.</p>

**Accessories**

Tools	Description	Type
	Service Tool, with ZIP-USB function, for parametrisable and communicative Belimo actuators, VAV controller and HVAC performance devices	ZTH EU
	Belimo PC-Tool, Software for adjustments and diagnostics	MFT-P
	Adapter for Service-Tool ZTH	MFT-C
	Connecting cable 5 m, A: RJ11 6/4 ZTH EU, B: 6-pin for connection to service socket	ZK1-GEN
	Connecting cable 5 m, A: RJ11 6/4 ZTH EU, B: free wire end for connection to MP/PP terminal	ZK2-GEN

Electrical installation



Supply from isolating transformer.

Direction of stroke switch factory setting: Actuator stem retracted (▲).

The wiring of the line for BACnet MS/TP / Modbus RTU is to be carried out in accordance with applicable RS-485 regulations.

Modbus / BACnet: Supply and communication are not galvanically isolated. Connect earth signal of the devices with one another.

Wire colours:

- 1 = black
- 2 = red
- 3 = white
- 5 = orange
- 6 = pink
- 7 = grey

Functions:

- C1 = D- = A
- C2 = D+ = B

Wiring diagrams

BACnet MS/TP / Modbus RTU

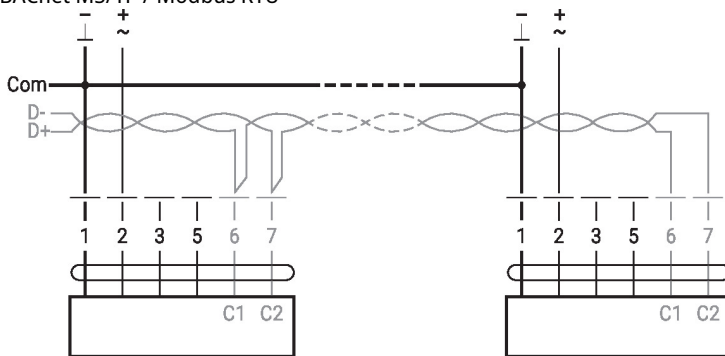

Functions

Functions with specific parameters (Parametrisation necessary)

Modbus RTU / BACnet MS/TP with analogue setpoint (hybrid mode)

Connection with active sensor, e.g. 0...10 V @ 0...50°C

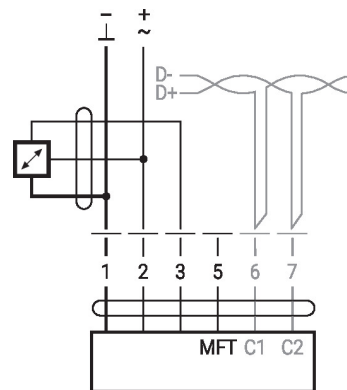
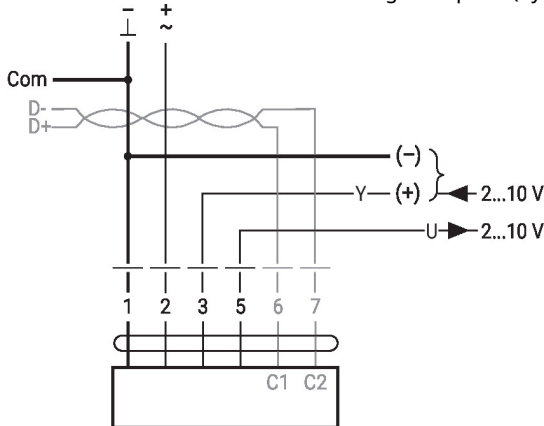

Possible input voltage range:  
0...10 V  
Resolution 30 mV

Connection with switching contact, e.g. Δp monitor

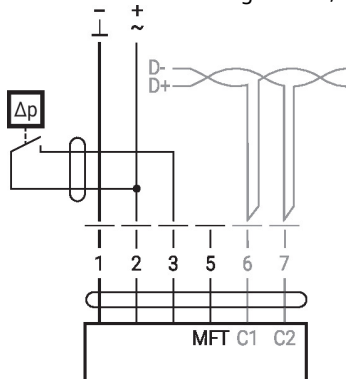

Switching contact requirements:  
The switching contact must be able to switch a current of 16 mA at 24 V accurately.  
Start point of the operating range must be parametrised on the MOD actuator as  $\geq 0.5$  V.

Connection with passive sensor, e.g. Pt1000, Ni1000, NTC

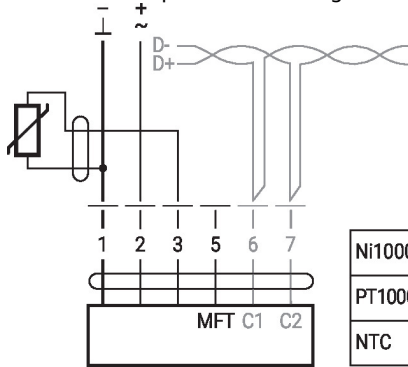

Ni1000	-28...+98°C	850...1600 Ω <sup>2)</sup>
PT1000	-35...+155°C	850...1600 Ω <sup>2)</sup>
NTC	-10...+160°C <sup>1)</sup>	200 Ω...60 kΩ <sup>2)</sup>

- 1) depending on type
  - 2) Resolution 1 Ohm
- Compensation of the measured value is recommended

Operation on the MP-Bus

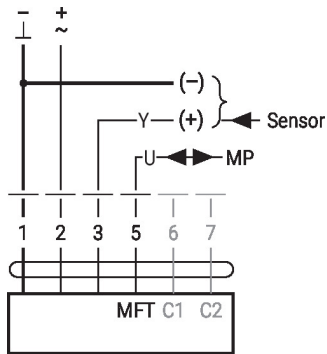

MP-Bus Network topology

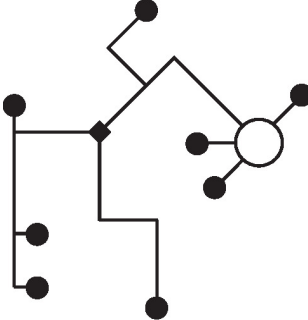

There are no restrictions for the network topology (star, ring, tree or mixed forms are permitted).  
Supply and communication in one and the same 3-wire cable

- no shielding or twisting necessary
- no terminating resistors required

Operating controls and indicators

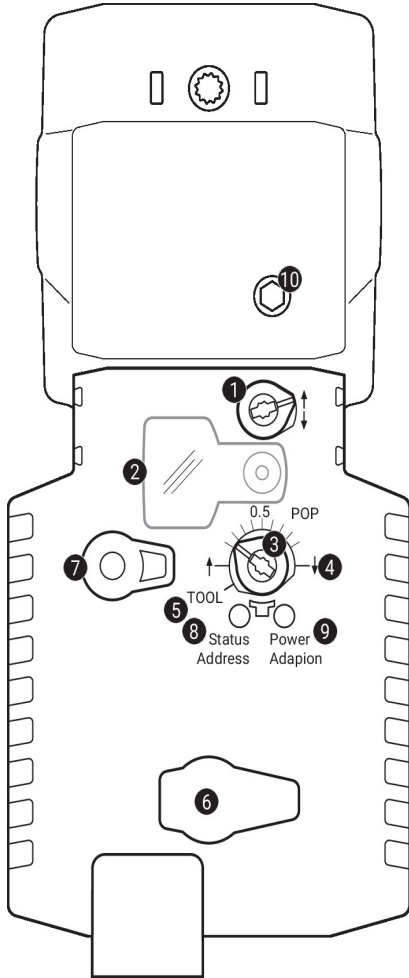

**1** Direction of stroke switch

Switch over: Direction of stroke changes

**2** Cover, POP button

**3** POP button

**4** Scale for manual adjustment

**5** Position for adjustment with tool

**6** Service plug

For connecting parametrisation and service tools

**7** Manual override button

Press button: Gear train disengages, motor stops, manual override possible

Release button: Gear train engages, standard mode

LED displays

yellow <b>8</b>	green <b>9</b>	Meaning / function
Off	On	Operation OK
Off	Flashing	POP function active When starting: Reset to factory setting (Communication)
On	Off	- Pre-charging time SuperCap - Fault SuperCap - Wiring error in supply
Off	Off	Not in operation
On	On	Adaptation or synchronisation process active
On	Flashing	Actuator in address mode Pulses according to set address (1...16)
Flickering	On	BACnet / Modbus communication active

**8** Push-button (LED yellow)

Press button: In operation (>3 s): Switch address mode on and off  
In address mode: Address setting by pressing several times  
When starting (>5 s): Reset to factory setting (Communication)

**9** Push-button (LED green)

Press button: In operation: Triggers stroke adaptation, followed by standard mode  
In address mode: Confirmation of set address (1...16)

**10** Manual override

Clockwise: Actuator stem extends  
Counterclockwise: Actuator stem retracts

## Setting emergency setting position (POP)

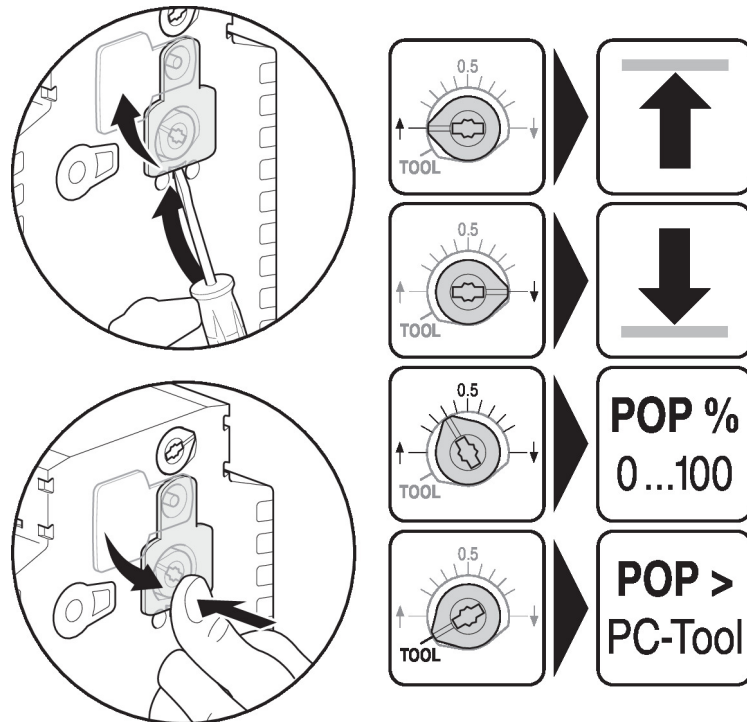

## Service

- Quick addressing**
1. Press the "Address" button until the green "Power" LED is no longer illuminated. LED flashes in accordance with the previously set address.
  2. Set the address by pressing the "Address" button the corresponding number of times (1...16).
  3. The green LED flashes in accordance with the address that has been entered (...16). If the address is not correct, then this can be reset in accordance with Step 2.
  4. Confirm the address setting by pressing the green "Adaptation" button.
- If no confirmation occurs for 60 seconds, then the address procedure is ended. Any address change that has already been started will be discarded.
- The resulting BACnet MS/TP and Modbus RTU address is made up of the set basic address plus the short address (e.g. 100+7=107).

- Tools connection**
- The actuator can be parametrised by ZTH EU via the service socket.  
For an extended parametrisation the PC tool can be connected.

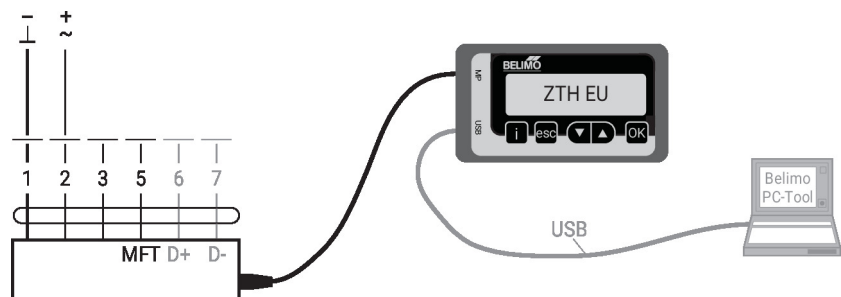



## Dimensions

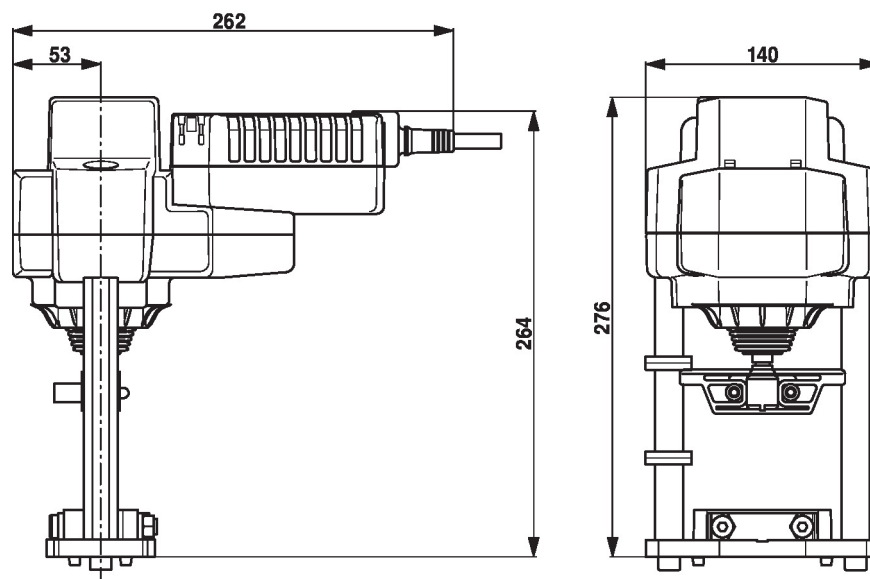

## Further documentation

- Tool connections
- BACnet Interface description
- Modbus Interface description
- Overview MP Cooperation Partners
- MP Glossary
- Introduction to MP-Bus Technology
- The complete product range for water applications
- Data sheets for globe valves
- Installation instructions for actuators and/or globe valves
- Notes for project planning 2-way and 3-way globe valves
- General notes for project planning