

Globe valve, 3-way, Flange, PN 16

- For closed cold and warm water systems
- For modulating control of air-handling and heating systems on the water side



### Type overview

| Type          | DN  | kvs<br>[m <sup>3</sup> /h] | Stroke | PN | Sv min. |
|---------------|-----|----------------------------|--------|----|---------|
| H7200W630-S7  | 200 | 630                        | 65 mm  | 16 | 30      |
| H7250W1000-S7 | 250 | 1000                       | 65 mm  | 16 | 30      |

### Technical data

|                        |                        |  |
|------------------------|------------------------|--|
| <b>Functional data</b> | Fluid                  | Cold and warm water, water with glycol up to max. 50% vol.                                   |
|                        | Fluid temperature      | -10...120°C [14...248°F]   |
|                        | Fluid temperature note | At a fluid temperature of -10...2°C, a spindle heating is needed.                            |
|                        | Flow characteristic    | Control path A – AB: linear (VDI/VDE 2173),<br>Bypass B – AB: linear (VDI/VDE 2173)          |
|                        | Leakage rate           | Control path A – AB: max. 0.05% of the kvs value;<br>Bypass B – AB: max. 1% of the kvs value |
|                        | Closing point          | Top (▲)  |
|                        | Pipe connection        | Flange PN 16 according to ISO 7005-2   |
|                        | Installation position  | upright to horizontal (in relation to the stem)  |
|                        | Servicing              | maintenance-free   |
| <b>Materials</b>       | Valve body             | EN-GJL-250 (GG 25)   |
|                        | Body finish            | with protective paint  |
|                        | Closing element        | Stainless steel  |
|                        | Spindle                | Stainless steel  |
|                        | Spindle seal           | EPDM   |
|                        | Seat                   | Stainless steel  |

### Safety notes



- The valve has been designed for use in stationary heating, ventilation and air-conditioning systems and must not be used outside the specified field of application, especially in aircraft or in any other airborne means of transport.
- Only authorised specialists may carry out installation. All applicable legal or institutional installation regulations must be complied during installation.
- The valve does not contain any parts that can be replaced or repaired by the user.
- The valve may not be disposed of as household refuse. All locally valid regulations and requirements must be observed.
- When determining the flow rate characteristic of controlled devices, the recognised directives must be observed.

## Product features

- Mode of operation** The large globe valve is adjusted by a long stroke actuator. The actuators are controlled by a commercially available modulating or 3-point control system and move the valve cone, which acts as a mixing device, to the opening position dictated by the control signal.
- Flow characteristic** A linear flow characteristic is produced in the direction of flow by the profile of the valve cone. The bypass exhibits a linear characteristic curve.
- Fluid velocity** Standard values for low-noise operation in HVAC systems are medium velocities of 1...2 m/s. At fluid velocities above 2 m/s, further flow effects as well as cavitation can occur. This can reduce the service life of a valve depending on the situation.

## Accessories

| Electrical accessories | Description                     | Type     |
|------------------------|---------------------------------|----------|
|                        | Stem heater DN 125...250 (60 W) | ZH24-1-D |
|                        | Stem heater DN 65...250 (60 W)  | ZH24-1-B |

## Installation notes

- Recommended installation positions** The large globe valves may be mounted from upright to horizontal. It is not permissible to mount the large globe valves with the stem pointing downwards.

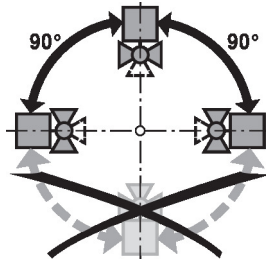

- Water quality requirements** The water quality requirements specified in VDI 2035 must be adhered to. Belimo valves are regulating devices. For the valves to function correctly in the long term, they must be kept free from particle debris (e.g. welding beads during installation work). The installation of a suitable strainer is recommended.

- Servicing** Large globe valves and long stroke actuators are maintenance-free. Before any service work on the control element is carried out, it is essential to isolate the long stroke actuator from the power supply (by unplugging the electrical cables if necessary). Any pumps in the part of the piping system concerned must also be switched off and the appropriate slide valves closed (allow all components to cool down first if necessary and always reduce the system pressure to ambient pressure level). The system must not be returned to service until the large globe valve and the long stroke actuator have been correctly reassembled in accordance with the instructions and the pipeline has been refilled by professionally trained personnel.

- Flow direction** The direction of flow, specified by an arrow on the housing, is to be complied with, since otherwise the valve could become damaged.

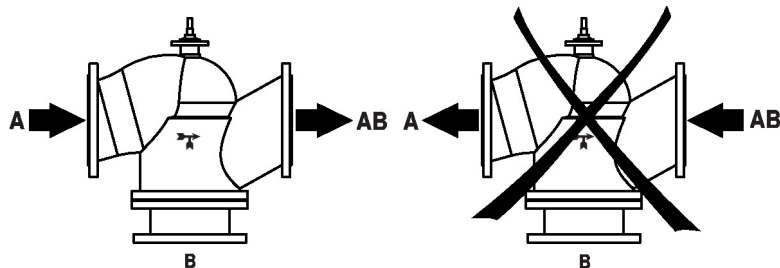

**Differential and close-off pressure**

The maximum differential and close-off pressure of globe valves depends on the mounted globe valve actuator. To ensure optimum operation and maximum service life, the maximum differential and close-off pressure in the table below must not be exceeded.

|  |     |                       |                           |
|--|-----|-----------------------|---------------------------|
| $p_s < 1600 \text{ kPa (PN16)}$<br>$t = 5 \dots 120^\circ\text{C}$ |     | GV12-...-T<br>12000N  |                           |
|  | DN  | $\Delta p_s$<br>[kPa] | $\Delta p_{max}$<br>[kPa] |
| H7200W630-S7   | 200 | 310                   | 60                        |
| H7250W1000-S7  | 250 | 190                   | 60                        |

**General notes**

**Delivery notes** Large globe valve and long stroke actuator are supplied pre-mounted.  
 These valves are fabricated only when orders are received.

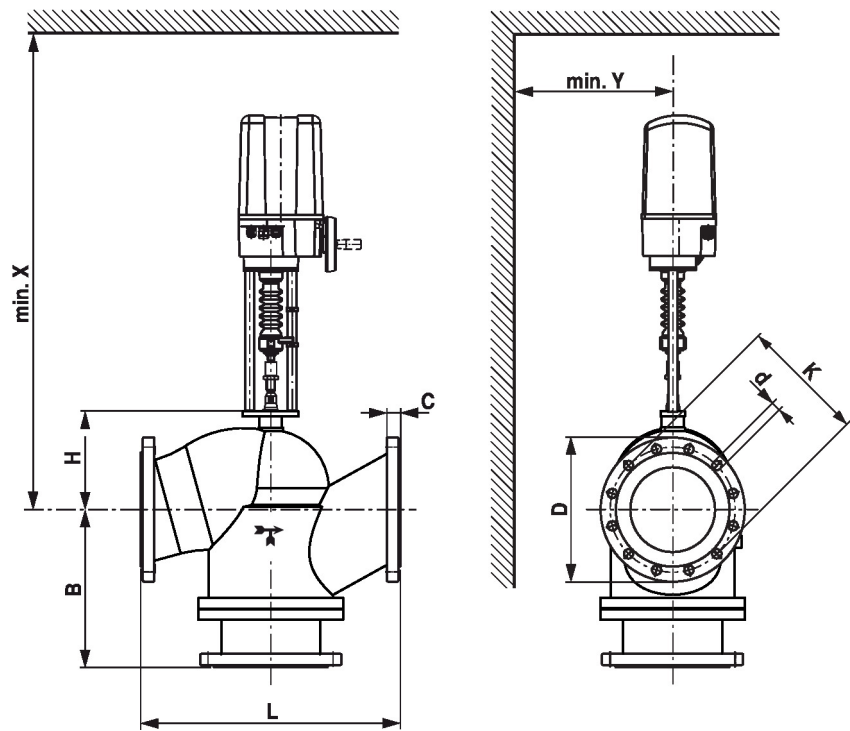
**Dimensions**
**Dimensional drawings**

X/Y: Minimum distance with respect to the valve centre.

Weight including GV.. long stroke actuator

The actuator dimensions can be found on the respective actuator data sheet.

| Type          | DN  | L<br>[mm] | B<br>[mm] | H<br>[mm] | C<br>[mm] | D<br>[mm] | d<br>[mm] | K<br>[mm] | X<br>[mm] | Y<br>[mm] | <br>kg |
|---------------|-----|-----------|-----------|-----------|-----------|-----------|-----------|-----------|-----------|-----------|--------|
| H7200W630-S7  | 200 | 600       | 380       | 315       | 30        | 340       | 12 x 22   | 295       | 1210      | 200       | 200    |
| H7250W1000-S7 | 250 | 730       | 440       | 375       | 32        | 405       | 12 x 26   | 355       | 1270      | 250       | 350    |

**Further documentation**

- The complete product range for water applications
- Data sheets long stroke actuators
- Installation instructions for valves and/or long stroke actuators
- Notes for project planning 2-way and 3-way globe valves