

Notes for project planning

Belimo ZoneTight™ QCV 2-way characterised control valve and 3-way changeover ball valve

Edition 2021-09/A

Table of contents

| | <u>Page</u> |
|--|-------------|
| General | |
| Introduction | |
| Relevant information | |
| Closing and differential pressures | |
| Pipeline clearances | |
| 2-way characterised control valves | 4 |
| 3-way changeover ball valves | |
| Water quality | |
| Strainer | |
| Isolation valve | |
| Design and dimensioning | |
| Control characteristics | |
| Design when using glycol | 5 |
| Flow characteristics | |
| Structure of the QCV control and changeover ball valves | |
| 2-way characterised control valve | 6 |
| 3-way changeover ball valve | |
| Installation | |
| Recommended installation position | |
| Direction of flow 2-way valve | 7 |
| Direction of flow 3-way valve | |
| Valve delivery condition | |
| Mounting actuator | 8 |
| Maintenance | |
| Type code | |
| Actuator | 9 |
| Valve | |
| Product features | |
| Adjustable angle of rotation | |
| k _v setting | 10 |
| Adaption | |
| Operating range | 11 |

| | <u>Page</u> |
|--|-------------|
| Selection table 2-way characterised control valve | 12 |
| Selection table 3-way changeover ball valve | 13 |
| <hr/> | |
| Dimensional diagram 2-way characterised control valve DN 15 | |
| Application | |
| Fluids | |
| Fluid temperatures | 14 |
| Formula k_v | |
| <hr/> | |
| Dimensional diagram 2-way characterised control valve DN 20 | |
| Application | |
| Fluids | |
| Fluid temperatures | 15 |
| Formula k_v | |
| <hr/> | |
| Dimensional diagram 2-way characterised control valve DN 25 | |
| Application | |
| Fluids | |
| Fluid temperatures | 16 |
| Formula k_v | |
| <hr/> | |
| Dimensioning table 3-way changeover ball valves | |
| Application | |
| Fluids | |
| Fluid temperatures | 17 |
| Formula Δp_{v100} | |
| <hr/> | |

General

Introduction

Belimo ZoneTight™ refers to regulating devices from Belimo that are used for room and zone applications in air conditioning technology. The Belimo ZoneTight™ zone valves are based on characterised control valve technology that has been proven a million times over and optimally meet the requirements. The space-saving QCV (Quick Compact Valve) is available as a 2-way characterised control valve with nominal diameters DN 15, DN 20 and DN 25 and also as a 3-way changeover ball valve with the same nominal diameters. The QCV can be combined with the CQ(K) rotary actuators and thus have distinctive features:

- Tight-closing zone valve that prevents circulation losses
- Minimum power consumption in operating and standby mode
- Compact overall structure
- Lightning-fast, manually adjustable flow rates with the 2-way characterised control valves
- Automatic adaption to set k_v value
- Valves resistant to contamination and sticking thanks to self-cleaning ball valve technology
- Actuator installed without any tools
- Compatible with 24 V, 230 V, open/close / 3-point, modulating control and communication (MP-Bus, BACnet, Modbus)

Relevant information

Please observe the data, information and limit values on the "characterised control valves" data sheets.

Closing and differential pressures

Please refer to the data sheets for the maximum permissible closing and differential pressures.

Pipeline clearances

The minimum clearances between the pipelines and the walls and ceilings required for project planning depend not only on the valve dimensions but also on the selected actuator and can be found in the data sheets of the valves and actuators.

2-way characterised control valves

2-way characterised control valves must be provided as throttling devices in the return. This leads to lower thermal loads on the sealing elements in the valve. The direction of flow is possible in both directions.

3-way changeover ball valves

3-way changeover ball valves are compact brass valves for use in heat pumps, underfloor heating or other HVAC applications. The main feature is the ability to quickly change the direction of flow between two circuits, which means energy-efficient operation. The direction of flow is possible in both directions.

Water quality

The requirements according to VDI 2035 regarding water quality must be observed.

Strainer

Characterised control valves are regulating devices. The use of strainers is recommended in order to prolong their service life for performing control tasks.

Isolation valve

Make sure that sufficient open/close valves are installed.

Design and dimensioning

Control characteristics

To ensure that a valve attains good control characteristics and thus a long service life for the HVAC performance device, it needs to be correctly designed with the correct valve authority.

The valve authority P_v is the benchmark for the control characteristics of the valve in combination with the hydronic network. The valve authority is the relation between the differential pressure of the fully open valve at nominal flow and the maximum differential pressure for the closed valve. The higher the valve authority, the better the control characteristics. The smaller the valve authority P_v becomes, the more the operational behaviour of the valve will deviate from the linearity i.e.. the poorer the volumetric flow control will be. A valve authority P_v of >0.5 is desired in everyday practice.

Design when using glycol

To reduce the freezing point of water, salt was added to the water in the past. These were called brine applications. Today glycol is used and we talk about cold agents. Depending on the concentration of the cold agent used (type of glycol) and the fluid temperature, the density of the water/glycol mixture varies between 1 and 9 percent. The resultant volume deviation is less than the permissible volume tolerance of the valve's k_{vS} value (by ± 10 percent according to VDE 2178) and as a rule need not be taken into account even if glycol requires a slightly higher k_v value. Depending on the type of glycol, compatibility with the valve materials used must be ensured. The permissible maximum concentration (50 percent) must not be exceeded.

Flow characteristics

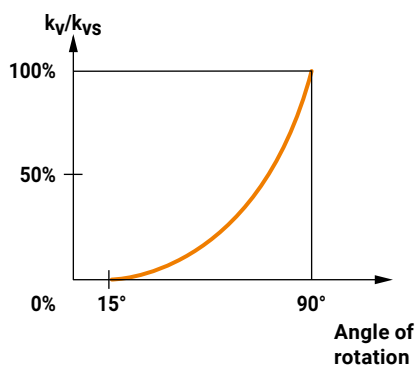

2-way characterised control valve

The characteristic curve is equal percentage with a characteristic curve factor $n(gl)$ of 3.2 or 3.9. This guarantees stable control characteristics in the upper partial load range. The curve is linear in the lower opening range between 0...30% operating range. This ensures outstanding control characteristics, also in the lower partial load range. The operating range 0...100% corresponds to an angle of rotation of 15...90°. With an angle of rotation of 0...15°, the characterised control valves operate as tight-closing open/close valves.

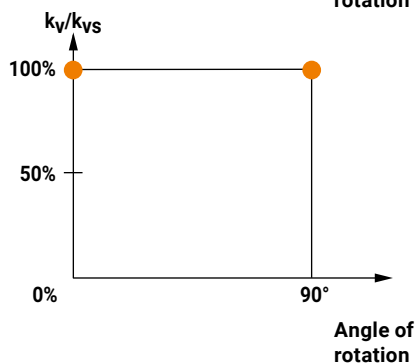

3-way changeover ball valve

Changeover ball valves are designed to be operated with an open/close actuator only. At an opening angle of 0°, the flow rate A – AB is guaranteed. Accordingly, at 90° (100% opening) B – AB is open. There is no permitted actuator position in between.

Structure of the QCV control and changeover ball valves

2-way characterised control valve

- 1 Connection A *
- 2 Spindle with flow marking and o-rings
- 3 Mounting flange (without tools)
- 4 Seat with o-ring
- 5 Ball
- 6 Seat with o-ring
- 7 Connection B *

* Internal thread according to ISO 7-1
External thread according to ISO 228-1

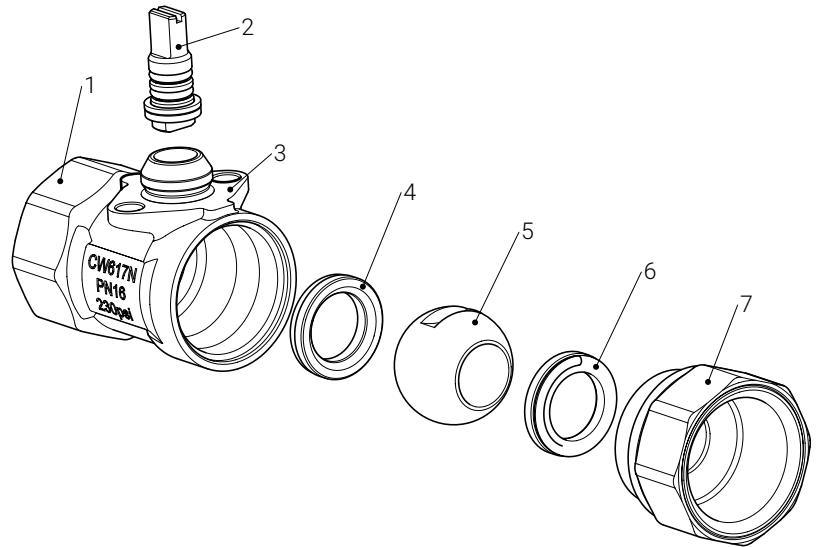

3-way changeover ball valve

- 1 Connection A *
- 2 Spindle with flow marking and o-rings
- 3 Mounting flange
- 4 Seat with o-ring
- 5 Ball
- 6 Seat with o-ring
- 7 Connection B *
- 8 Connection AB *

* Internal thread according to ISO 7-1
External thread according to ISO 228-1

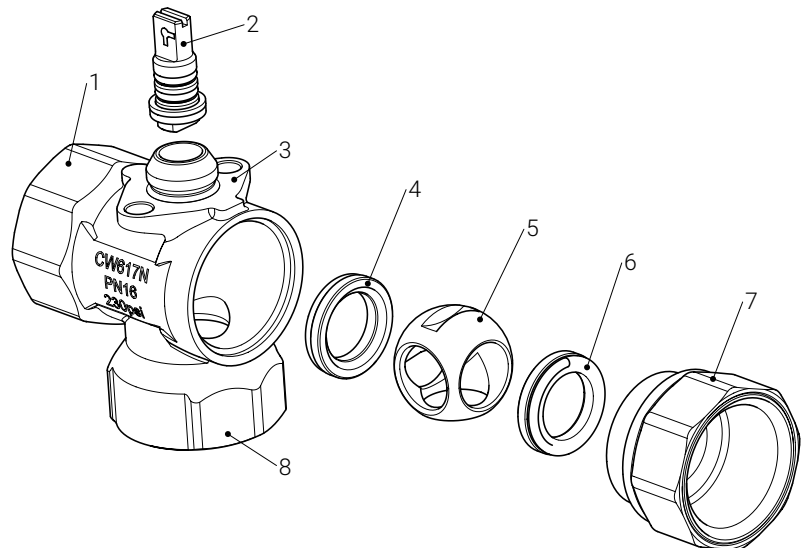

Installation

Recommended installation position

The ball valve can be installed upright to horizontal. It is not permissible to install the ball valve suspended, i.e. with the spindle pointing downwards.

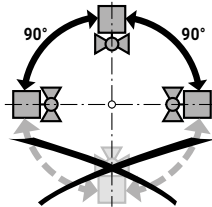

Direction of flow 2-way valve



Direction of flow possible in both directions.

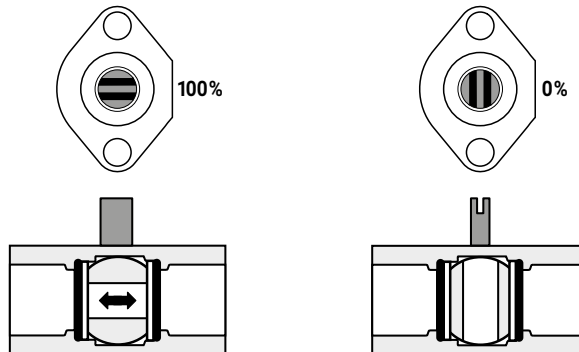

Direction of flow 3-way valve



Direction of flow possible in both directions.

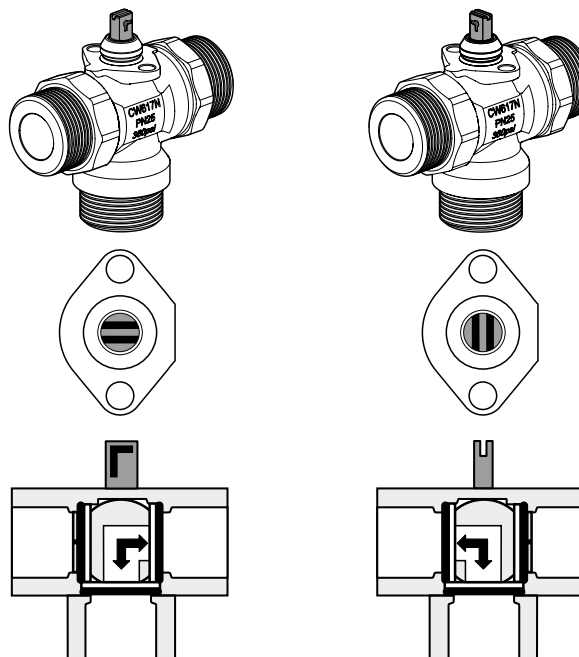

Valve delivery condition

The valves are delivered ex works according to the pictures below.

2-way characterised control valve

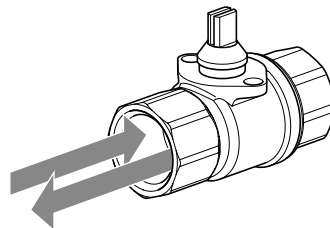

3-way changeover ball valve

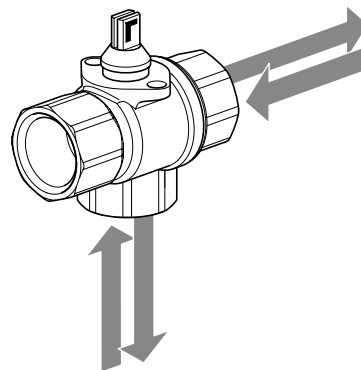

Delivery condition conforms to valve position 90°/positioning signal 10 V.

Mounting actuator

Tool-free snap-assembly.

The actuator can be plugged on the valve by hand (Caution! Just vertical movements). Pins must match the holes on the flange. The orientation of the actuator (0° or rotated by 180°) when plugged onto the valve has no influence on the function.

Maintenance

QCV 2-way characterised control valves and 3-way changeover ball valves are maintenance-free.

For all service work on the HVAC performance device, the power supply to the rotary actuator must be switched off (disconnect electrical cables if necessary). All pumps in the corresponding pipeline element must be switched off and the associated slide valves closed (if necessary, allow all components to cool down first and always reduce the system pressure to ambient pressure). Commissioning may only be carried out after the ball valve and full-rotation actuator have been correctly mounted in accordance with the instructions and the pipeline has been refilled by qualified personnel.

Type code

Actuator



Example:

CQKC24A-SR-T

| | |
|---------------|-----------------------------------|
| Not specified | = Cable 1 m |
| T | = Terminal design |
| Not specified | = Open/close, 3-point |
| SZ | = Modulating 0.5...10 V |
| SR | = Modulating 2...10 V |
| MPL | = Belimo MP-Bus light |
| BAC | = BACnet/Modbus |
| 24A | = AC/DC 24 V |
| 230A | = AC 230 V |
| Not specified | = Running time 75 s |
| C | = Fast running 35 s |
| D | = Very fast running 15 s |
| Not specified | = Without fail-safe |
| K | = Fail-safe actuator (electrical) |
| Q | = Quick connection for zone valve |
| C | = Torque 1 Nm |

Valve



Example:

C215 Q-J

| | |
|----|--|
| F | = Flow rate value 0.1...1.3 m ³ /h |
| H | = Flow rate value 2.2...3.5 m ³ /h |
| J | = Flow rate value 3.6...5.6 m ³ /h |
| K | = Flow rate value 5.7...8.8 m ³ /h |
| Q | = Quick connection (tool-free actuator mounting) |
| 15 | = DN 15 |
| 20 | = DN 20 |
| 25 | = DN 25 |
| 2 | = Internal thread, 2-way characterised control valve |
| 3 | = Internal thread, 3-way changeover ball valve |
| 4 | = External thread, 2-way characterised control valve |
| 5 | = External thread, 3-way changeover ball valve |
| C | = Compact (zone valve) |

Product features

Adjustable angle of rotation

The position of the end stop clip on the rotary actuator can be changed in 2.5° steps. This is used to adjust the k_v value (maximum flow of the valve). The adjustable angle of rotation is only valid for the QCV 2-way characterised control valves and must not be used for the QCV 3-way changeover ball valves. For the 3-way types, it is essential to remove the end stop clip on the CQ(K) actuator.

An exact description of how to handle the end stop clip can be found in the installation instructions of the actuator used.

k_v setting

Remove the end stop clip and place at the desired position (without end stop clip k_{vS} value of valve). Every time the k_v setting is changed with the end stop clip, an adaptation must be triggered on the modulating actuator.

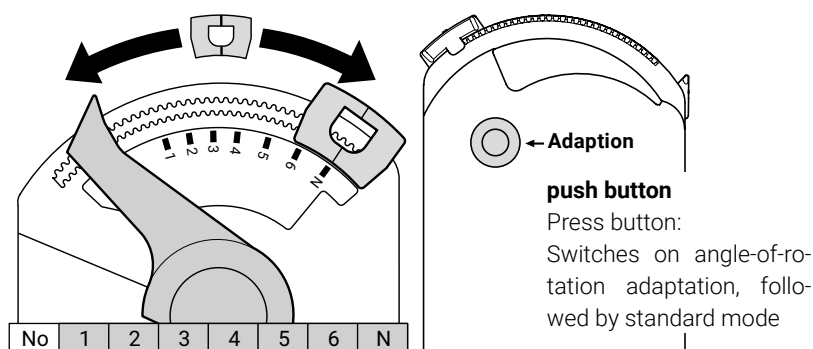

Adaption

When the supply voltage is switched on for the first time, i.e. during commissioning, the modulating variable actuators CQ(K)24ASR(-T), CQ(K)24A-SZ(-T), CQ(K)24A-MPL(-T) and CQ24A-BAC perform an adaptation. Every time the k_v setting is changed with the end stop clip, an adaptation must be triggered on the modulating actuator.

| Product type from Belimo | k_v [m³/h] | Position number CQ.. actuators | | | | | | | |
|--------------------------|--------------|--------------------------------|------|-----|-----|------|------|-----------------|-----|
| | | 1 | 2 | 3 | 4 | 5 | 6 | N ¹⁾ | 2) |
| C215Q-F | ■ | 0.09 | 0.14 | 0.2 | 0.3 | 0.48 | 0.72 | 1 | 1.2 |
| C215Q-J | ■ | 0.4 | 0.6 | 1 | 1.5 | 2 | 2.9 | 4 | 4.8 |
| C220Q-K | ■ | 0.5 | 0.9 | 1.4 | 2.1 | 2.9 | 4 | 5.7 | 8 |
| C225Q-K | ■ | 0.5 | 0.8 | 1.3 | 1.9 | 2.7 | 3.7 | 5.2 | 7 |
| C415Q-J | ■ | 0.4 | 0.6 | 1 | 1.4 | 1.9 | 2.6 | 3.7 | 4.5 |
| C420Q-K | ■ | 0.5 | 0.9 | 1.4 | 2.1 | 2.9 | 4 | 5.7 | 7.8 |

¹⁾ Factory setting
²⁾ Without end stop clip

Operating range

Due to its design, the ball valve has an operating range in the opening direction of 15...90°, i.e. up to 15° is the air-bubble tight range. Also due to the design, there is a switching differential of 4°, i.e. in the closing direction the QCV is only air-bubble tight from 11°.

At the smallest adjustable k_v value (position number 1), the angle of rotation of the valve is still 36.5°. Thus the actuator adapts to the angle 0...36.5°, 15° of which is the air-bubble tight range, i.e. 41% at this flow rate setting. If the actuator has an operating range of 0.5...10 V (for 0...36.5°), then the effective operating range of the valve is between 4.4 and 10 V.

The running time of the actuator is 75 s/90°, i.e. for the setting at position number 1 there is a running time of 30 s for 36.5°. The operating ranges of the valves at the corresponding position numbers are:

Modulating variable actuators

| Position number CQ.. actuator | Fully open position at [°] | Running time [s] | CQ(K)24A-SR(-T) | | CQ(K)24A-SZ(-T) | |
|----------------------------------|-------------------------------|---------------------|---|-------------------------|---|-------------------------|
| | | | Operating range combination in opening direction [V] | Number of control steps | Operating range combination in opening direction [V] | Number of control steps |
| 1 | 36.5 | 30 | 5.3...10 | 59 | 4.4...10 | 70 |
| 2 | 44 | 37 | 4.7...10 | 67 | 3.7...10 | 79 |
| 3 | 51.5 | 43 | 4.3...10 | 72 | 3.3...10 | 84 |
| 4 | 59 | 49 | 4.0...10 | 75 | 2.9...10 | 94 |
| 5 | 66.5 | 55 | 3.8...10 | 78 | 2.6...10 | 89 |
| 6 | 74 | 62 | 3.6...10 | 80 | 2.4...10 | 95 |
| N | 81.5 | 68 | 3.5...10 | 82 | 2.2...10 | 98 |
| 1) ¹⁾ | 90 | 75 | 3.3...10 | 84 | 2.1...10 | 99 |

¹⁾ Without clip

Calculation of control steps actuator:

- Operating range (e.g. 3.3...10 V) $10...3.3 \text{ V} = 6.7 \text{ V}$
- Response sensitivity: $80 \text{ mV} = 0.08 \text{ V}$
- Control steps actuator: $6.7 \text{ V} / 0.08 \text{ V} = 84 \text{ steps}$

Opening limit angle (tight - flow rate): approx. 15° in opening direction

Switching differential combination: 3.5...4°

Closing limit angle (flow rate - tight): approx. 11° in closing direction

Actuator running time: 75 s / 90°

Recommendation for the smallest k_v values (item numbers 1 and 2):

- The QCV must not be used with a P-controller (permanent control offset).
- The QCV may only be used in a closed control loop with PI or PID control.
- In case of doubt, use the QCV only as an open/close unit.

Actuators with running times of 35 s (e.g. CQC230A) and 15 s (e.g. CQD230A) are also available.

Selection table 2-way characterised control valve

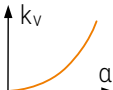
| | |
|--------------------------------|---|
| Fluid temperature | 2...90°C |
| Max. differential pressure | Δp_{\max} : 280 kPa |
| Permissible operating pressure | p_s : 1600 kPa |
| Valve design |  |
| Valve characteristic curve |  |

| DN | Valve type from Belimo | | | | | | Actuator type from Belimo | | | | | | | | | |
|------------------------------|------------------------|---------|---------|---------|---------|---------|----------------------------------|-----------------|-----------------|--------------|---------------|------------------|---------------|------------------|------------|------------|
| | C215Q-F | C215Q-J | C220Q-K | C225Q-K | C415Q-J | C420Q-K | Position number CQ.. actuator | CQ(K)24A-SR(-T) | CQ(K)24A-SZ(-T) | CQ(K)24A(-T) | CQ(K)230A(-T) | CQ(K)24A-MPL(-T) | CQ(K)K24A(-O) | CQ(K)K24A-SR(-O) | CQ(K)C230A | CQ(K)D230A |
| | 15 | 15 | 20 | 25 | 15 | 20 | | | | | | | | | | |
| | k_v | k_v | k_v | k_v | k_v | k_v | | | | | | | | | | |
| | 0.09 | 0.4 | 0.5 | 0.5 | 0.4 | 0.5 | 1 | ■ | ■ | ■ | ■ | ■ | ■ | ■ | ■ | ■ |
| | 0.14 | 0.6 | 0.9 | 0.8 | 0.6 | 0.9 | 2 | ■ | ■ | ■ | ■ | ■ | ■ | ■ | ■ | ■ |
| | 0.2 | 1 | 1.4 | 1.3 | 1 | 1.4 | 3 | ■ | ■ | ■ | ■ | ■ | ■ | ■ | ■ | ■ |
| | 0.3 | 1.5 | 2.1 | 1.9 | 1.4 | 2.1 | 4 | ■ | ■ | ■ | ■ | ■ | ■ | ■ | ■ | ■ |
| | 0.48 | 2 | 2.9 | 2.7 | 1.9 | 2.9 | 5 | ■ | ■ | ■ | ■ | ■ | ■ | ■ | ■ | ■ |
| | 0.72 | 2.9 | 4 | 3.7 | 2.6 | 4 | 6 | ■ | ■ | ■ | ■ | ■ | ■ | ■ | ■ | ■ |
| | 1 | 4 | 5.7 | 5.2 | 3.7 | 5.7 | N | ■ | ■ | ■ | ■ | ■ | ■ | ■ | ■ | ■ |
| | 1.2 | 4.8 | 8 | 7 | 4.5 | 7.8 | ¹⁾ | ■ | ■ | ■ | ■ | ■ | ■ | ■ | ■ | ■ |
| Internal thread ISO 7-1 | ■ | ■ | ■ | ■ | | | | | | | | | | | | |
| External thread ISO 228-1 | | | | | ■ | ■ | | | | | | | | | | |

¹⁾ Without end stop clip

Selection table 3-way changeover ball valve

Fluid temperature 2...90°C
 Max. differential pressure Δp_{\max} : 280 kPa
 Permissible operating pressure p_g : 1600 kPa



Valve design

| | Valve type from Belimo | | | | | Actuator type from Belimo | | | | | | |
|--------------------------------------|------------------------|----------|----------|----------|----------|-------------------------------------|--------------|---------------|---------|---------|------------------|-----------|
| | C315Q-H | C320Q-J | C325Q-J | C515Q-H | C520Q-J | Position number CQ(K).. actuator | CQ(K)24A(-T) | CQ(K)230A(-T) | CQC230A | CQD230A | CQ(K)24A-MPL(-T) | CQ24A-BAC |
| DN | 15 | 20 | 25 | 15 | 20 | | | | | | | |
| | k_{vs} | k_{vs} | k_{vs} | k_{vs} | k_{vs} | | | | | | | |
| | 2.5 | 4.0 | 4.0 | 2.3 | 3.6 | ¹⁾ | ■ | ■ | ■ | ■ | ■ | ■ |
| Internal thread ISO 7-1 | ■ | ■ | ■ | | | | | | | | | |
| External thread ISO 228-1 | | | | ■ | ■ | | | | | | | |

¹⁾ Without end stop clip

Dimensional diagram 2-way characterised control valve DN 15

Application

These characterised control valves are used in closed cold and hot water systems for modulating water-side control of air handling units and heating systems.

Fluids

Cold and hot water, water with glycol up to max. 50% vol.

Fluid temperatures

2...90°C

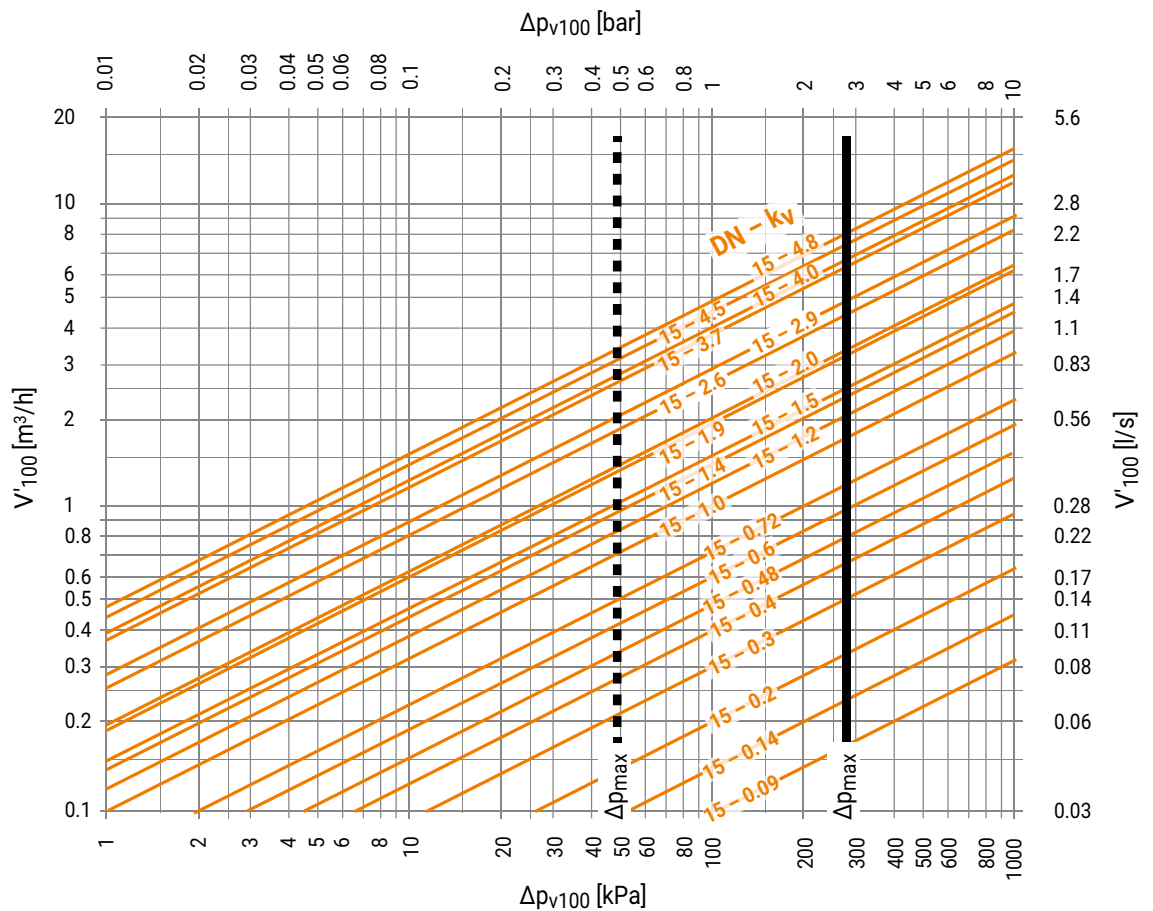

Formula k_v

$$k_v = \frac{V'_{100}}{\sqrt{\frac{\Delta p_{v100}}{100}}}$$

Δp_{v100} : [kPa]
 V'_{100} : [m³/h]
 k_v : [m³/h]

DN – k_v corresponds to the end stop clip position.

— Δp_{max}

Maximum permissible differential pressure (280 kPa) for long service life over the control path A – AB related to the entire opening range

- - Δp_{max}

Maximum permissible differential pressure for low-noise operation (50 kPa)

Δp_{v100}

Differential pressure at maximum ball valve opening position

V'_{100}

Nominal flow rate at Δp_{v100}

Dimensional diagram 2-way characterised control valve DN 20

Application

These characterised control valves are used in closed cold and hot water systems for modulating water-side control of air handling units and heating systems.

Fluids

Cold and hot water, water with glycol up to max. 50% vol.

Fluid temperatures

2...90°C

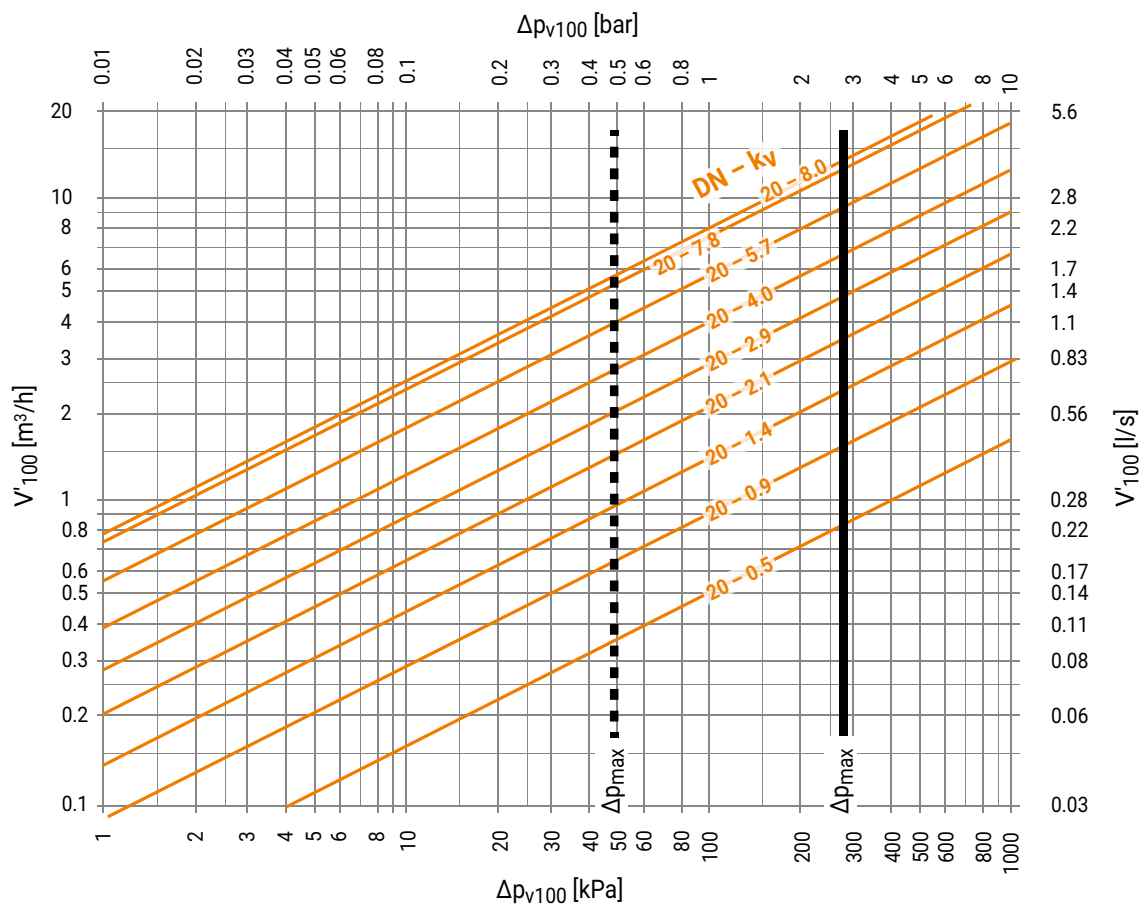

Formula k_v

$$k_v = \frac{V'_{100}}{\sqrt{\frac{\Delta p_{v100}}{100}}}$$

Δp_{v100} : [kPa]
 V'_{100} : [m³/h]
 k_v : [m³/h]

DN - k_v corresponds to the end stop clip position.

— Δp_{max}

Maximum permissible differential pressure (280 kPa) for long service life over the control path A – AB related to the entire opening range

- - Δp_{max}

Maximum permissible differential pressure for low-noise operation (50 kPa)

Δp_{v100}

Differential pressure at maximum ball valve opening position

V'_{100}

Nominal flow rate at Δp_{v100}

Dimensional diagram 2-way characterised control valve DN 25

Application

These characterised control valves are used in closed cold and hot water systems for modulating water-side control of air handling units and heating systems.

Fluids

Cold and hot water, water with glycol up to max. 50% vol.

Fluid temperatures

2...90°C

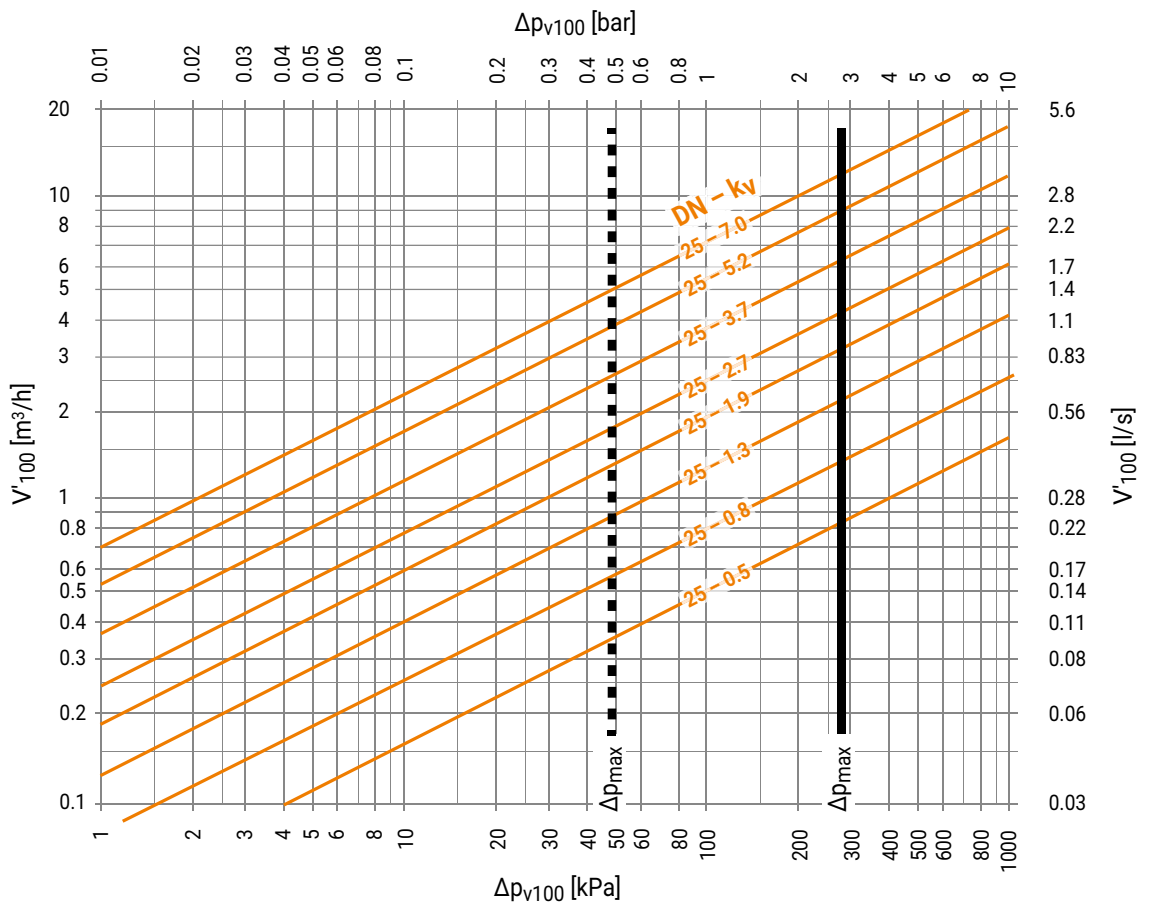

Formula k_v

$$k_v = \frac{V'_{100}}{\sqrt{\frac{\Delta p_{v100}}{100}}}$$

Δp_{v100} : [kPa]
 V'_{100} : [m³/h]
 k_v : [m³/h]

DN - k_v corresponds to the end stop clip position.

— Δp_{max}

Maximum permissible differential pressure (280 kPa) for long service life over the control path A – AB related to the entire opening range

- - Δp_{max}

Maximum permissible differential pressure for low-noise operation (50 kPa)

Δp_{v100}

Differential pressure at maximum ball valve opening position

V'_{100}

Nominal flow rate at Δp_{v100}

Dimensioning table 3-way changeover ball valves

Application

These changeover ball valves are used in closed cold and hot water systems for modulating water-side control of air handling units and heating systems.

Fluids

Cold and hot water, water with glycol up to max. 50% vol.

Fluid temperatures

2...90°C

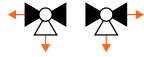
| Differential pressure Δp_{v100} [kPa] | 50* | 280 | k_{vs} [m ³ /h] | DN [mm] |  | Connections |
|--|-----|-----|---------------------------------|------------|---|-----------------|
| Flow rate V'_{100} [m ³ /h] | 1.8 | 4.2 | 2.5 | 15 | C315Q-H | Internal thread |
| | 2.8 | 6.7 | 4 | 20 | C320Q-J | Internal thread |
| | 2.8 | 6.7 | 4 | 25 | C325Q-J | Internal thread |
| | 1.6 | 3.8 | 2.3 | 15 | C515Q-H | External thread |
| | 2.5 | 6.0 | 3.6 | 3.6 | C520Q-J | External thread |

Formula Δp_{v100}

$$\Delta p_{v100} = \left(\frac{V'_{100}}{k_{vs}} \right)^2 \cdot 100$$

Δp_{v100} : [kPa]
 V'_{100} : [m³/h]
 k_{vs} : [m³/h]

Δp_{max}

Maximum permissible differential pressure (280 kPa) for long service life over the control path A – AB related to the entire opening range

* Maximum permissible differential pressure for low noise operation at 50 kPa

Δp_{v100}

Differential pressure with ball valve full open

V'_{100}

Nominal flow rate at Δp_{v100}

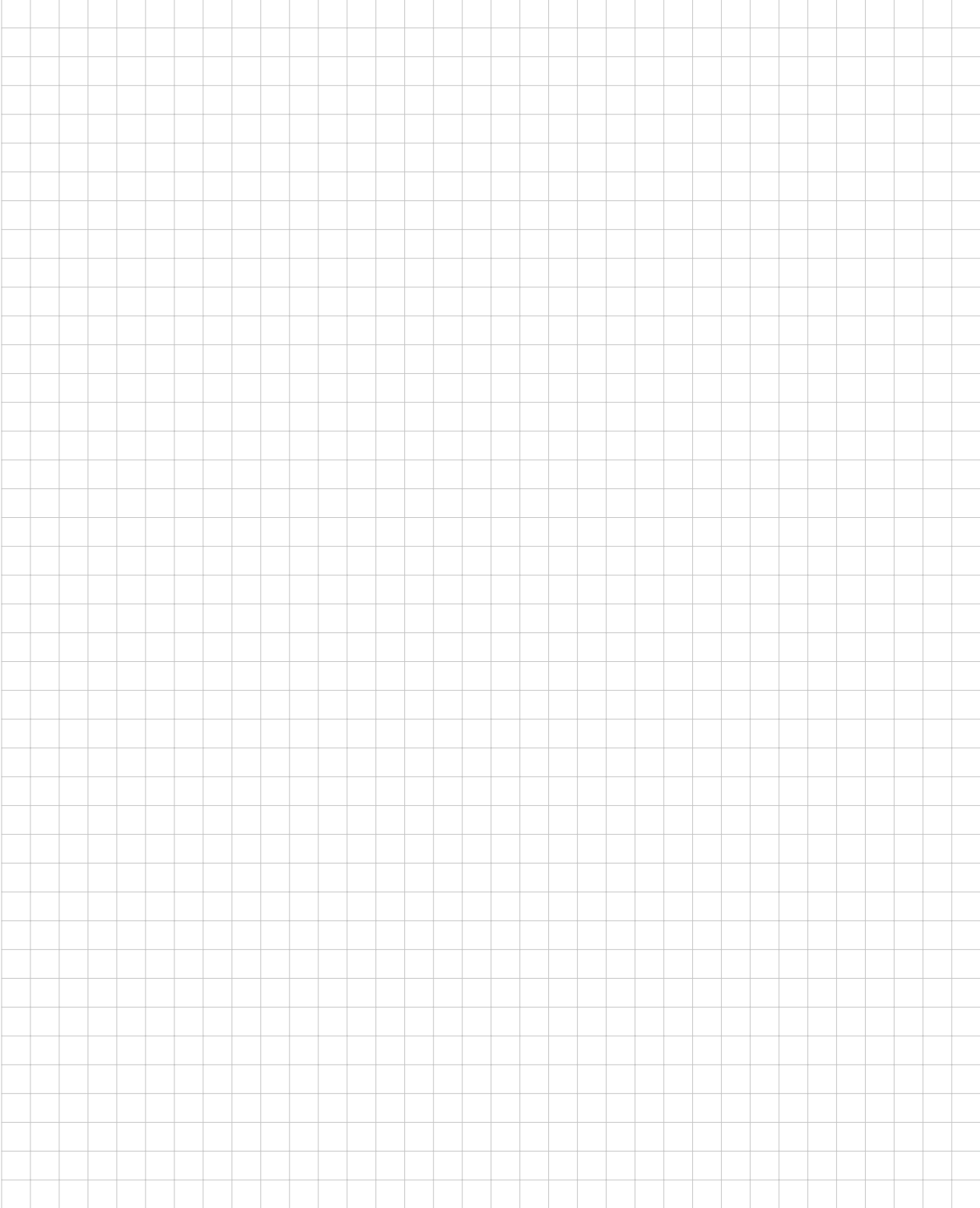

All inclusive.

Belimo as a global market leader develops innovative solutions for the controlling of heating, ventilation and air-conditioning systems. Actuators, valves and sensors represent our core business.

Always focusing on customer added value, we deliver more than only products. We offer you the complete product range for the regulation and control of HVAC systems from a single source. At the same time, we rely on tested Swiss quality with a five-year warranty. Our worldwide representatives in over 80 countries guarantee short delivery times and comprehensive support through the entire product life. Belimo does indeed include everything.

The "small" Belimo devices have a big impact on comfort, energy efficiency, safety, installation and maintenance.

In short: Small devices, big impact.



5-year warranty



On site around the globe



Complete product range



Tested quality



Short delivery times



Comprehensive support



BELIMO Automation AG

Brunnenbachstrasse 1, 8340 Hinwil, Switzerland
+41 43 843 61 11, info@belimo.ch, www.belimo.com

BELIMO[®]