

### ■ Mounting accessories

#### LB

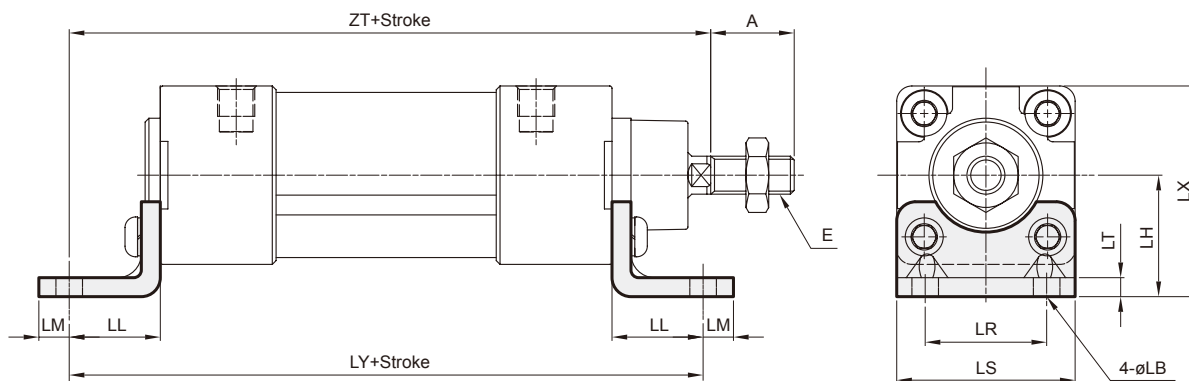

Code Tube I.D.	A	E	LB	LH	LL	LM	LR	LS	LT	LX	LY	ZT
32	22	M10×1.25	7	32	24	8	32	47	5	55.5	142	144
40	24	M12×1.25	9	36	28	10	36	53	5	63.2	161	163
50	32	M16×1.5	9	45	32	10	45	65	5	77.5	170	175
63	32	M16×1.5	9	50	32	10	50	75	5	89	185	190
80	40	M20×1.5	12	63	41	13	63	95	6	110.5	210	215
100	40	M20×1.5	14	71	41	13	75	115	6	128.5	220	230

### FAC

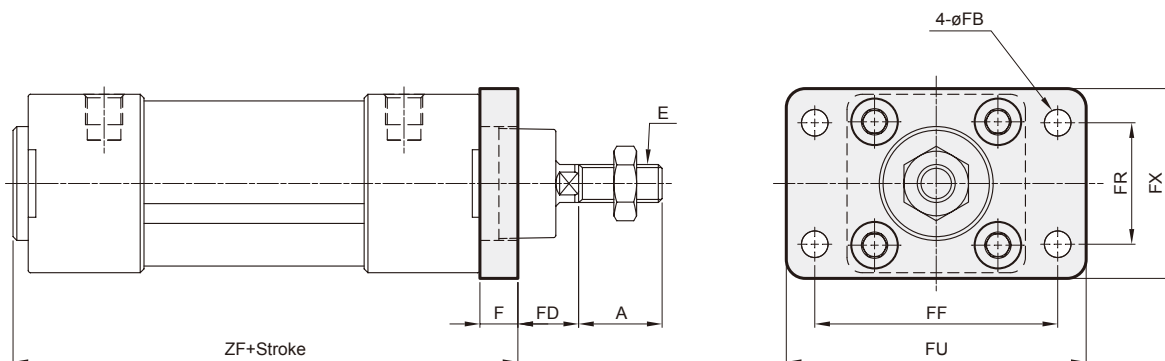

Code Tube I.D.	A	E	F	FB	FD	FF	FR	FU	FX	ZF
32	22	M10×1.25	10	7	16	64	32	79	50	108
40	24	M12×1.25	10	9	20	72	36	93	54	120
50	32	M16×1.5	12	9	25	90	45	112	67	123
63	32	M16×1.5	12	9	25	100	50	127	79	137
80	40	M20×1.5	16	12	30	126	63	158	98	148
100	40	M20×1.5	16	14	35	150	75	185	116	158

### FBC

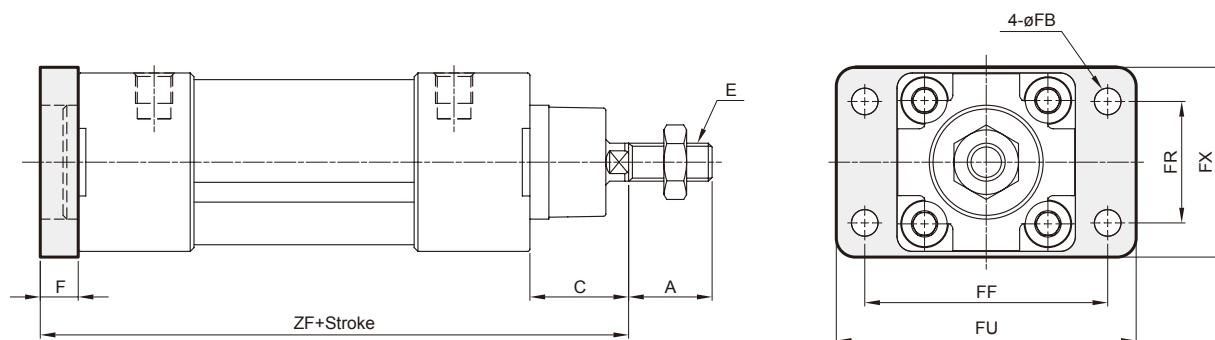

Code Tube I.D.	A	C	E	F	FB	FF	FR	FU	FX	ZF
32	22	26	M10×1.25	10	7	64	32	79	50	130
40	24	30	M12×1.25	10	9	72	36	93	54	145
50	32	37	M16×1.5	12	9	90	45	112	67	155
63	32	37	M16×1.5	12	9	100	50	127	79	170
80	40	46	M20×1.5	16	12	126	63	158	98	190
100	40	51	M20×1.5	16	14	150	75	185	116	205

### CA

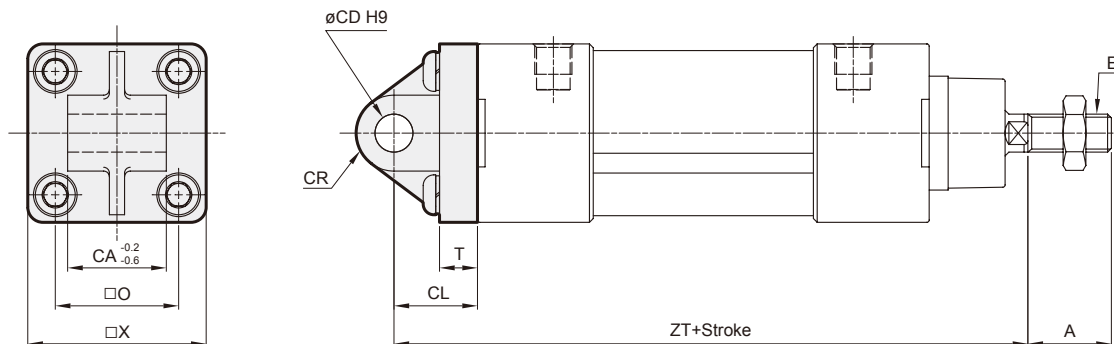

Code Tube I.D.	A	CA	CD	CL	CR	E	O	T	X	ZT
32	22	26	10	22	R10.5	M10×1.25	32.5	10	46	142
40	24	28	12	25	R12	M12×1.25	38	9	52	160
50	32	32	12	27	R13	M16×1.5	46.5	9	63.5	170
63	32	40	16	32	R17	M16×1.5	56.5	9	75	190
80	40	50	16	36	R17	M20×1.5	72	12	93	210
100	40	60	20	41	R21	M20×1.5	89	11	112	230

### CB

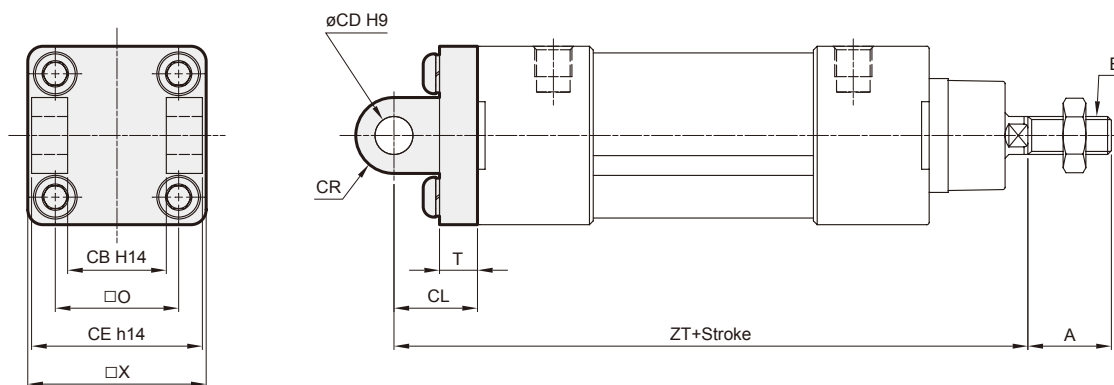

Code Tube I.D.	A	CB	CD	CE	CL	CR	E	O	T	X	ZT
32	22	26	10	45	22	R10.5	M10×1.25	32.5	10	46	142
40	24	28	12	52	25	R12	M12×1.25	38	9	52	160
50	32	32	12	60	27	R14	M16×1.5	46.5	9	63.5	170
63	32	40	16	70	32	R17	M16×1.5	56.5	9	75	190
80	40	50	16	90	36	R17	M20×1.5	72	12	93	210
100	40	60	20	110	41	R21	M20×1.5	89	11	112	230

### CDB CB+Pin (Extra purchase)

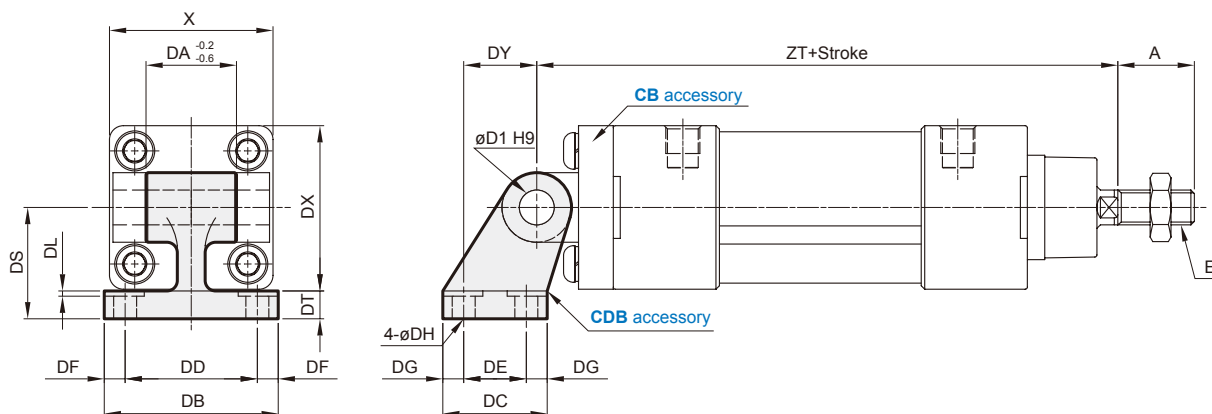

Code Tube I.D.	A	DA	DB	DC	DD	DE	DF	DG	DH	DI	DL	DS	DT	DX	DY	E	X	ZT
32	22	26	50	30	38	18	6	6	6.6	10	1.5	32	8	47.5	21	M10×1.25	47	142
40	24	28	53	34	41	22	6	6	6.6	12	1.5	36	10	52.5	24	M12×1.25	55	160
50	32	32	65	45	50	30	7.5	7.5	9	12	1.5	45	12	65.5	33	M16×1.5	65	170
63	32	40	67	50	52	35	7.5	7.5	9	16	1.5	50	12	75.5	37	M16×1.5	78	190
80	40	50	86	60	66	40	10	10	11	16	2.5	63	14	96.5	47	M20×1.5	95	210
100	40	60	96	70	76	50	10	10	11	20	2.5	71	15	113.5	55	M20×1.5	115	230

### TC

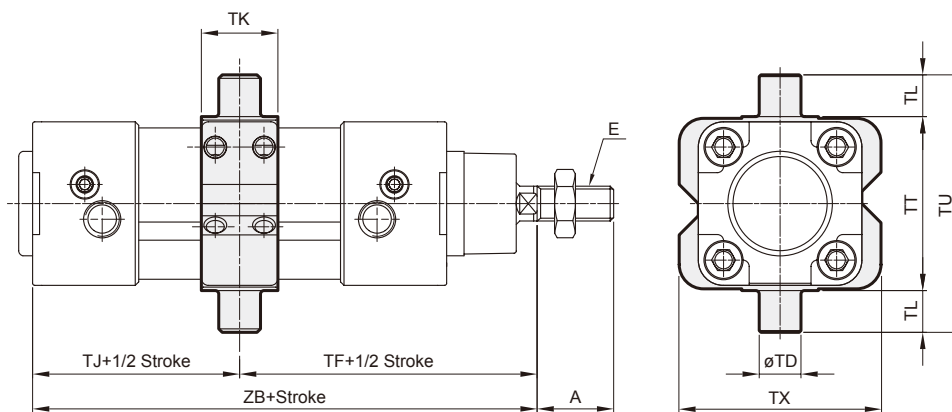

Code Tube I.D.	A	E	TD	TF	TJ	TK	TL	TT	TU	TX	ZB
32	22	M10×1.25	12 <sup>øB</sup>	73	47	22	12	50	74	58	120
40	24	M12×1.25	16 <sup>øB</sup>	82.5	52.5	28	16	63	95	70	135
50	32	M16×1.5	16 <sup>øB</sup>	90	53	32	16	75	107	85	143
63	32	M16×1.5	20 <sup>øB</sup>	97.5	60.5	35	20	90	130	100	158
80	40	M20×1.5	20 <sup>øB</sup>	110	64	40	20	110	150	120	174
100	40	M20×1.5	25 <sup>øB</sup>	120	69	45	25	132	182	145	189

### TA

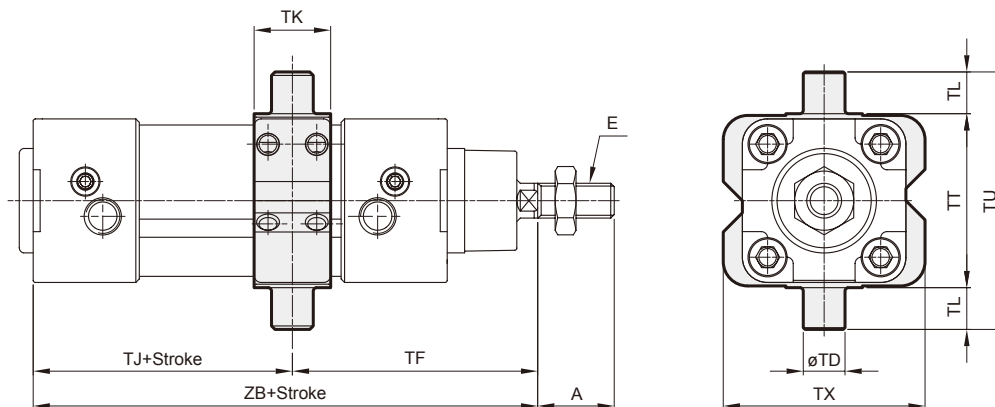

Code Tube I.D.	A	E	TD	TF	Without magnet		Magnet		TK	TL	TT	TU	TX
					TJ	ZB	TJ	ZB					
32	22	M10×1.25	12 <sup>øB</sup>	70.5	49.5	120	79.5	150	22	12	50	74	58
40	24	M12×1.25	16 <sup>øB</sup>	81	54	135	84	165	28	16	63	95	70
50	32	M16×1.5	16 <sup>øB</sup>	87	56	143	86	173	32	16	75	107	85
63	32	M16×1.5	20 <sup>øB</sup>	90.5	67.5	158	97.5	188	35	20	90	130	100
80	40	M20×1.5	20 <sup>øB</sup>	104.5	69.5	174	109.5	214	40	20	110	150	120
100	40	M20×1.5	25 <sup>øB</sup>	113.5	75.5	189	115.5	229	45	25	132	182	145

### TB

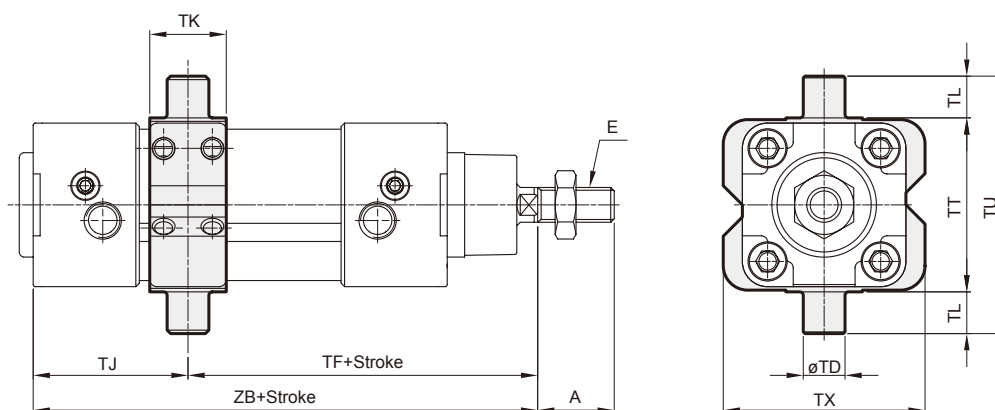

Code Tube I.D.	A	E	TD	TJ	Without magnet		Magnet		TK	TL	TT	TU	TX
					TF	ZB	TF	ZB					
32	22	M10×1.25	12 <sup>øB</sup>	44.5	75.5	120	105.5	150	22	12	50	74	58
40	24	M12×1.25	16 <sup>øB</sup>	51	84	135	114	165	28	16	63	95	70
50	32	M16×1.5	16 <sup>øB</sup>	50	93	143	123	173	32	16	75	107	85
63	32	M16×1.5	20 <sup>øB</sup>	53.5	104.5	158	134.5	188	35	20	90	130	100
80	40	M20×1.5	20 <sup>øB</sup>	58.5	115.5	174	155.5	214	40	20	110	150	120
100	40	M20×1.5	25 <sup>øB</sup>	62.5	126.5	189	166.5	229	45	25	132	182	145

# MCQI2 Cylinder weight $\varnothing 32 \sim \varnothing 100$



ISO-VDMA **STANDARD PROFILE CYLINDER**

Mindman

## Cylinder weight

Unit: kg

Model	Basic weight MCQI2-11	Basic weight (magnet) MCQI2-11	Stroke 25 mm MCQI2-11
Tube I.D.			
$\varnothing 32$	0.544	0.550	0.064
$\varnothing 40$	0.822	0.834	0.091
$\varnothing 50$	1.260	1.277	0.128
$\varnothing 63$	1.838	1.858	0.116
$\varnothing 80$	2.754	2.781	0.209
$\varnothing 100$	4.086	4.121	0.234

Model	LB	CA	CB	CDB	FAC/FBC	TA/TB/TC	Y	I	Pin (Y&I)	Pin (CA&CB)
Tube I.D.										
$\varnothing 32$	0.163	0.213	0.185	0.170	0.235	0.208	0.070	0.080	0.02	0.040
$\varnothing 40$	0.211	0.253	0.211	0.230	0.265	0.282	0.115	0.141	0.03	0.065
$\varnothing 50$	0.315	0.390	0.352	0.410	0.460	0.377	0.272	0.334	0.08	0.072
$\varnothing 63$	0.395	0.670	0.544	0.550	0.684	0.675	0.272	0.334	0.08	0.145
$\varnothing 80$	0.816	1.076	0.982	0.870	1.508	1.025	0.551	0.553	0.16	0.179
$\varnothing 100$	1.014	1.587	1.493	1.400	1.975	1.680	0.551	0.553	0.16	0.330