

3/2-Way Solenoid Valve

TP-SERIES

- 3/2-WAY BRASS/STAINLESS STEEL SOLENOID VALVE
- DIRECT OPERATED
- NC / NO / DIVERTING / UNIVERSAL
- RELIABLE OPERATION
- INTEGRATED MOUNTING POINTS





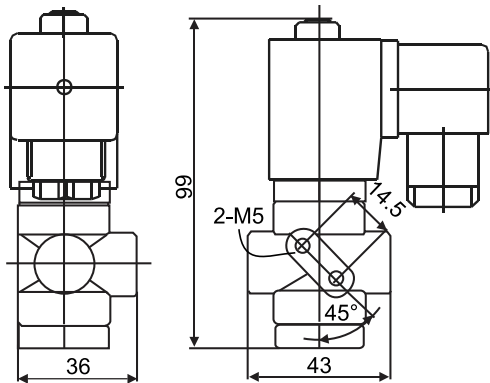
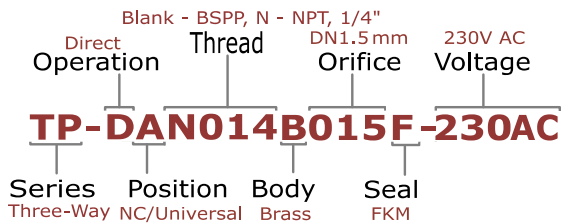

The TP series consists of different types of 3/2-way solenoid valves, suitable for a variety of applications such as actuating pneumatic equipment, draining, distribution or mixing of liquids and gases.

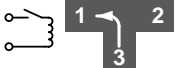
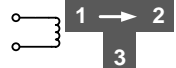
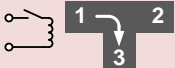
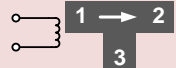

Series	TP	
Operation	3/2-way - Direct Operated	
Pipe Port	G1/8 " BSP (018) or G1/4" BSP (014)	
Housing	Brass (B) / Stainless Steel 316 (S)	
Seal & Media Temperature	NBR (N)	-20..80°C
	EPDM (E)	-30..130°C
	FKM (F)	-20..120°C
Thread	BSPP / NPT (N)	
Ambient Temperature	Max 50°C	
Min. Pressure Difference	0 bar	
Coil Series	CS1	
	380V AC 50Hz (380AC)	
	230V AC 50/60Hz (230AC)	
	120V AC 50Hz (120AC)	
	24V AC 50/60Hz (024AC)	
	24V DC (024DC)	
Voltage	12V DC (012DC)	
	Insulation Class: Class F	
	Power: 13 W / 17 VA	
Duty Cycle	100% ED	
Connector	EN 175301-803 (DIN 43650A)	
Protection Class	IP 65 (with cable plug)	

Orifice (mm)	1.5 (015)	2 (020)	2.5 (025)	3 (030)	4 (040)
Kv (m3/h)	0.06	0.12	0.18	0.21	0.30

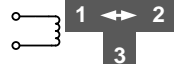
Normally Closed (A) same valve as Universal			Max. Pressure (bar) AC/DC	13/11	11/9	9/7	6/4	3.5/2
	Normally Open (B)				13/11	11/9	9/7	6/4
Diverting (C)				Max. Pressure (bar) AC/DC	13/11	11/9	9/7	6/4
	Universal (D) same valve as Normally Closed				Max. Pressure (bar) AC/DC	7/5	5/4	4/3

1. TECHNICAL SPECIFICATIONS

1.1. Principle of operation

A solenoid valve is a valve for neutral, clean liquids and gases, which is electrically controlled with the aid of a solenoid. 3/2 way means that the valve has three ports and two positions in order to determine the flow.

The solenoid consists of a coil and a movable plunger. The plunger is ferromagnetic. The valve has two internal ports that are be shut off by a rubber seal. Once the solenoid is activated with an electric current, the plunger is lifted up by the magnetic field, whereby one orifice opens and the other closes. This results in a new combination of two ports which are connected. Two springs hold the plungers in position. The 3/2-way solenoid valves are direct operated and operate from 0 bar.

1.2. Area of application

Body material

The TP series is available with a brass or stainless steel body material. Depending on the application, the right material should be selected.

Body material	Allowed media
Brass (ASTM #37800)	Neutral and non-corrosive media.
Stainless Steel (SS 316)	Suitable for aggressive media and corrosive media like seawater.

Diaphragm

The TP-series is available with FKM, NBR or EPDM. Depending on the application the correct diaphragm should be selected. In the following table a concise overview is presented of compatible media.

Diaphragm	Temperature	Allowed media	Not allowed
FKM	-10°C..120°C	Most fuels and oils, cold water, detergents, compressed air.	Glycol-based brake fluids, ammonia gas, hot water and steam, low molecular weight organic acids (such as acetic acid).
EPDM	-30°C..130°C	Water and steam, alcohol.	Oils, fats, fuels, solvents.
NBR	-10°C..80°C	Neutral media, like air, cold water, hydraulic oil.	Fuels, strong acids, brake fluid.

1.1. Flow chart

In the flow chart, the flow of water from 20°C is shown as a function of the positive pressure difference across the valve. The flow rate is expressed in liters per minute and the pressure in bar.

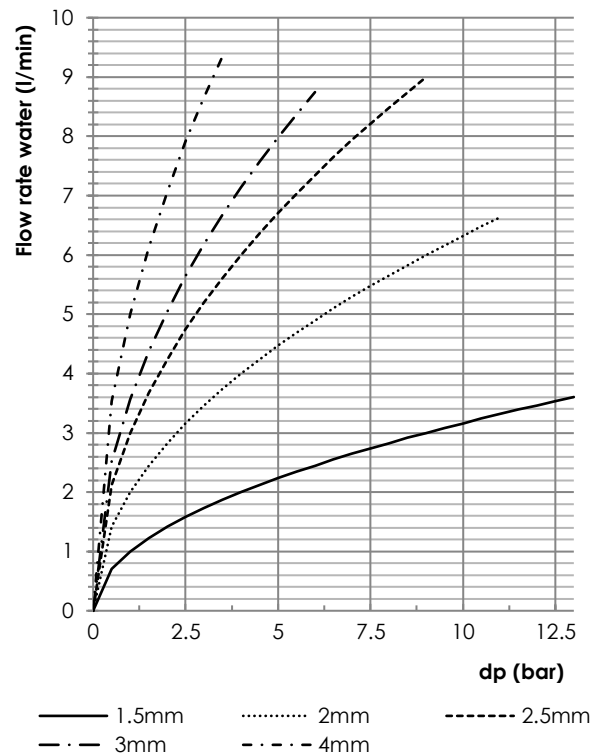

1.2. Duty cycle

The solenoid valve is suitable for continuous use. High switching frequencies and high pressures can reduce the lifespan.

1.3. Compliance

The coils are CE marked and comply with the LVD Directive (2006/95/EC) and EMC Directive (2004/108/EC), provided that the cables and connectors are properly connected.

1.4. Type label

The coil properties are displayed on a label on the coil. A second label is provided with the valve that shows all relevant valve parameters. This label must be attached to the other side of the coil. In the figure below, an example is shown.

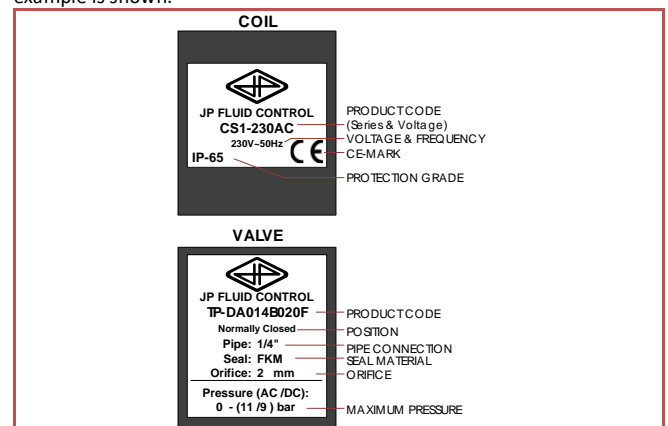

1.1. Exploded view

In the figure below an exploded drawing of the TP series is displayed.

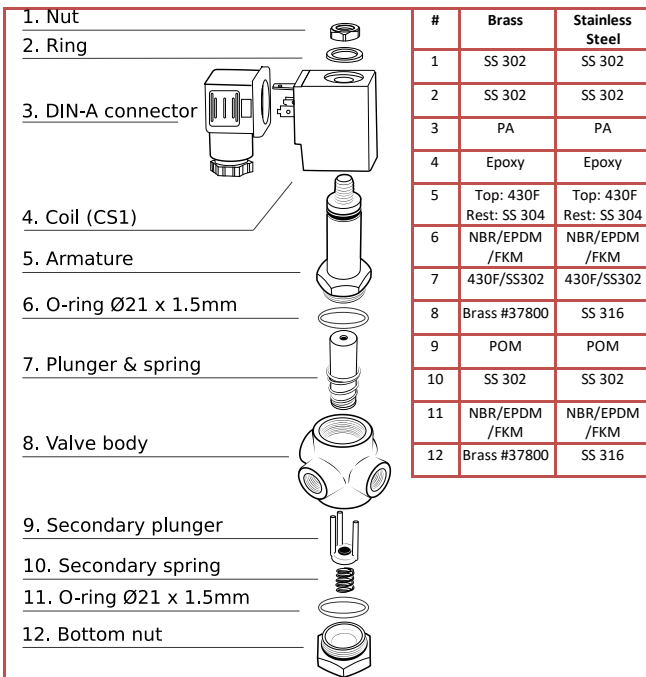

2. GENERAL SAFETY INSTRUCTIONS

- ▶ This product is not a safety device and may not be used as such.
- ▶ Damage caused by improper use, falling, improper operating conditions or other reasons, may cause improper functioning of the solenoid. Correct transport, proper storage and installation, and proper use and maintenance, are essential for reliable and error-free operation.
- ▶ It is the responsibility of the user to select the right product for the application.
- ▶ The product may not function properly as a result of dirt, wear, damage (for example, by dropping) or improper use. Therefore, the product should not be used in applications where a malfunction can cause danger or damage.
- ▶ This product is not intended or approved for medical applications, food and/or application in gas appliances.
- ▶ Solenoid valves can only be used with clean liquids or gases. It is recommended to install a filter before the solenoid valve.
- ▶ Check the compatibility of the medium used, temperature and other operating conditions with the materials and specifications of the product.
- ▶ Never exceed the limits for pressure, temperature or voltage as indicated on the product and/or in the technical documentation.
- ▶ The temperature of a solenoid valve coil can rise during operation; this is normal. Overheating will cause smoke and a burning smell. In this case, the power supply must immediately be disconnected.
- ▶ Warning: a valve opens and closes quickly. Improper use can cause pressure transients (fluid hammer) in the pipes with possible damage as a consequence.
- ▶ It is not allowed to change the construction of the valve.
- ▶ Beware of electric shock when working with electrical equipment.

3. INSTALLATION AND MAINTENANCE

1.1. Safety instructions before starting

- ▶ It is recommended to install the product in a dry environment. In moist environments, make sure that no moisture can penetrate the coil, actuator or connector. Install the solenoid valve in a safe way to avoid electric shock, burning or other injuries. Ensure that the solenoid valve is installed in an area with adequate ventilation to facilitate heat

dissipation. Make sure the solenoid valve is not in contact with or in the vicinity of flammable materials. Ensure that the product is protected from frost. Frost may damage the product and/or block the moving parts, causing the product to malfunction.

- ▶ Operations may only be performed when the system is not pressurized, electrically disconnected and cooled down.
- ▶ Turn off the power supply before performing any work on the solenoid valve to prevent the risk of electrical shock and to prevent activation of the solenoid valve.
- ▶ The product is only safe when properly installed and operated by qualified persons. Please read the safety instructions and technical documentation carefully before installation, use or maintenance.
- ▶ Always make sure to start the installation safely after installation or maintenance.
- ▶ Water hammer is a typical consequence of a high flow rate and pressure in pipes with small diameters. There are several solutions to this problem:
 - ▶ Reduce the pressure with a pressure reducing valve before the solenoid valve.
 - ▶ Increase the pipe diameter if possible.
 - ▶ Dampen the water hammer by using a flexible hose or buffer before the solenoid valve.

1.2. Installation

Clean fluids and gases

The solenoid valve can be used in combination with clean liquids or gases. Check if there is any dirt in the piping or valve before installing. It is recommended to install a filter (500 µm) before the solenoid valve.

Mounting the valve

Be aware of the direction of flow of the medium when installing the valve. Solenoid valves with an arrow on the housing must be connected in the indicated direction. The pipes on both sides of the valve must be securely fastened. Use a wrench for both valve and pipe while tightening to prevent unnecessary stresses in the system. The solenoid valve must be fixed via the provided connection points. Only exert force at the designated areas on the body such as the hexagon; never to the coil or armature. Avoid vibration in the pipes. Use a suitable sealant for threaded connections of the solenoid valve. Avoid the entry of thread sealing material in the valve, this can lead to malfunctioning of the valve.

Position

It is recommended to install the solenoid in vertical position with the coil facing upwards. This reduces the probability of the collection of debris in the solenoid valve. When the solenoid valve is mounted at an angle, it is recommended to deviate maximally 90° from the vertical position.

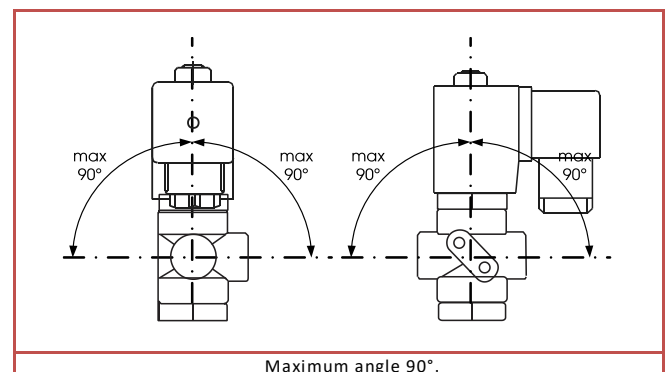

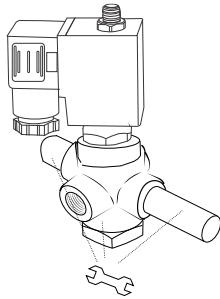

Only exert force at the designated faces, never at the coil or armature.

Installation of the coil

- ▶ Attach the label with the valve characteristics on the coil.
- ▶ The device can be damaged by the use of unsuitable tools.
- ▶ The temperature of the coil increases during use, this is normal. Overheating will cause smoke and a burning smell. In this case, the power supply must be shut down immediately.
- ▶ The coils can be rotated if the coil nut is loosened. After the determination of the correct position, the nut should be fastened with a torque of 5Nm.

Installation of the cable plug

- ▶ Always connect the ground (3), which is provided with a residual current device at voltages above 50V. Never use liquid or gas piping for grounding electrical equipment. The power supply is connected to terminals (1) and (2). The polarity does not matter.
- ▶ Verify the voltage and frequency before connecting the coil.
- ▶ When mounting the connector, make sure that no moisture can ingress between the coil and connector. The connector screws should be fastened with a torque of 0.5Nm.

Connecting the power supply

- ▶ Never connect power to the coil when it is not attached to the solenoid valve! The coil may burn out.
- ▶ Only connect power if you are sure that there is no pressure in the system and no hazardous situations can occur.

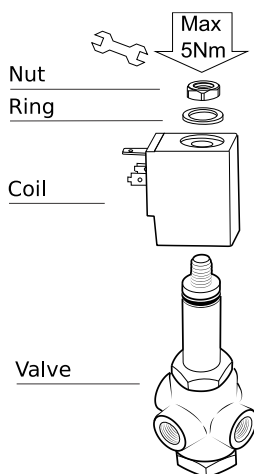

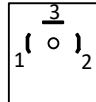

1
2
3

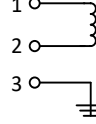

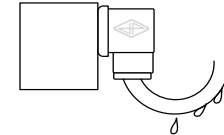

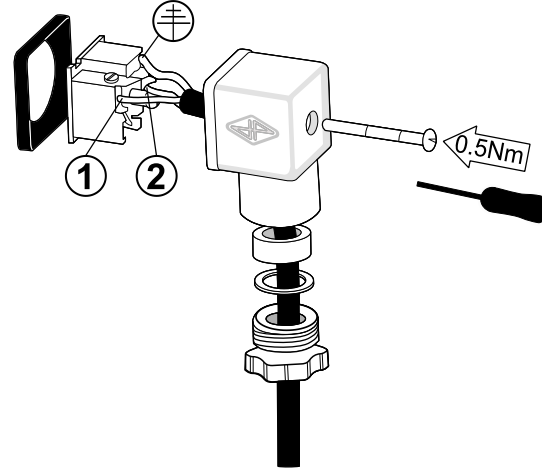

Connector: EN 175301-803 Type A (formerly DIN 43650A). The poles (1) and (2) should be connected to the power supply, polarity is not important. Pole (3) is the ground. Connect the connector thoroughly to avoid ingress of moisture. Ensure that drops cannot slip along the cable and enter the connector.

4. SPARE PARTS

The wear parts of the solenoid valve can be replaced with a repair kit (plunger, plunger spring, O-ring):

Product code	Circuit Function	Seal
TP-D--N-REV	NC/Universal	NBR
TP-D--E-REV	NC/Universal	EPDM
TP-D--F-REV	NC/Universal	FKM
TP-DB-N-REV	Normally open	NBR
TP-DB-E-REV	Normally open	EPDM
TP-DB-F-REV	Normally open	FKM
TP-DC-N-REV	Diverting	NBR
TP-DC-E-REV	Diverting	EPDM
TP-DC-F-REV	Diverting	FKM

The coil can be replaced. The product codes of the coil are shown in the table below:

Product code	Voltage
CS1-380AC	380V AC 50Hz
CS1-230AC	230V AC 50Hz
CS1-120AC	120V AC 60Hz
CS1-024AC	24V AC 50Hz
CS1-024DC	24V DC
CS1-012DC	12V DC

5. DISPOSAL

- ▶ The removal of the product should be performed in accordance with the applicable laws.