

Low Pressure Solenoid Valve

LP-SERIES

- 2/2-WAY SOLENOID VALVE
- DIRECT OPERATED
- NORMALLY CLOSED
- ALUMINIUM BODY WITH SOFT NBR/FKM SEAT
- SUITABLE FOR LOW PRESSURE SYSTEMS
- RELIABLE SHUT-OFF
- SUITABLE FOR NEUTRAL GASSES



The LP series consists of different types of 2/2-way solenoid valves. The solenoid valves are available in diameters from 9 mm and operate from 0 to 2000 mbar. The housing is made of die-cast aluminum and is available with NBR or FKM seal. The LP-DA series is used for clean neutral gases, this series is not suitable for liquids.

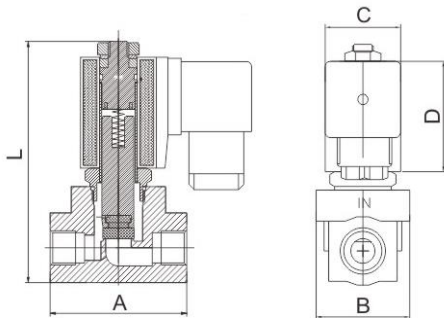
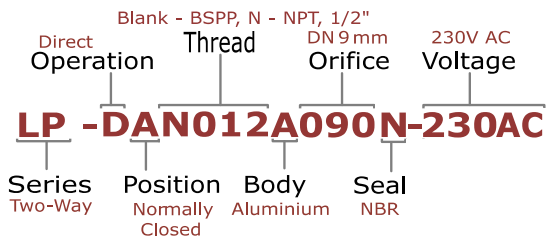

Series	LP	
Operation	2/2-way - Direct Operated	
Pipe Port	See Table	
Housing	Aluminium (A)	
Seal & Media Temperature	NBR (N)	-10..65°C
	FKM (F)	-10..65°C
Thread	BSPP / NPT (N)	
Ambient Temperature	Max 50°C	
Min. Pressure Difference	0 bar	
Coil Series	CS1 or CS2	
Voltage	380V AC 50Hz (380AC)	
	230V AC 50Hz (230AC)	
	120V AC 60Hz (120AC)	
	24V AC 50Hz (024AC)	
	24V DC (024DC)	
	12V DC (012DC)	
Insulation Class	Class F	
Power	13 W / 22 VA (CS1)	
	20 W / 33 VA (CS2)	
Duty Cycle	100% ED	
Connector	EN 175301-803 (DIN 43650A)	
Protection Class	IP 65 (with cable plug)	

Pipe Port (P)	Orifice (D)	Max Pressure (bar)	Kv (m3/h)	Dimensions (mm)			Coil
				A	B	L	
1/4" (014)	6mm (060)	2	0.69	51	35	91	CS1
3/8" (038)	9mm (090)	0.6	1.21	51	35	91	CS1
1/2" (012)	9mm (090)	0.6	1.21	51	35	91	CS1
1/2" (012)	20mm (200)	0.36	6.49	70	73	122	CS2
3/4" (034)	20mm (200)	0.36	6.49	70	73	122	CS2
1" (100)*	25mm (250)	0.36	11.25	90	75	127	*
1 1/4" (114)*	45mm (450)	0.5	26.8	137	122	208	*
1 1/2" (112)*	45mm (450)	0.5	26.8	137	122	208	*
2" (200)*	45mm (450)	0.5	26.8	137	122	208	*

*Models available on request

1. TECHNICAL SPECIFICATIONS

1.1. Principle of operation

A solenoid valve is a valve for neutral, clean liquids and gases, which is electrically controlled with the aid of a solenoid. 2/2 way means that the valve has two ports (input/output) and two positions (closed/open). The valve is normally closed, this means that the valve is closed when de-energized.

The solenoid consists of a coil and a movable plunger. The plunger is ferromagnetic and at the bottom of the plunger is a sealing gasket. In the valve is an orifice which is closed by the gasket. Once the solenoid is activated with an electric current, the plunger is lifted up by the magnetic field, whereby the orifice opens and the medium can flow through. A small spring holds the plunger in closed position when the valve is not energized. This working principle is called direct operation.

1.2. Area of application

Body material

The LP series is supplied with an aluminium housing and is moderately corrosive resistant. The valve is suitable for air or inert gases with a low operating pressure.

Sealing

The LP-series is available with FKM and NBR. Depending on the application the correct diaphragm should be selected. In the following table a concise overview is presented of compatible media.

Diaphragm	Temperature	Allowed media	Not allowed
FKM	-10°C..65°C	Compressed air & neutral media.	Ammonia gas, steam, low molecular weight organic acids (such as acetic acid).
NBR	-10°C..65°C	Neutral media, like air.	Strong acids.

1.1. Flow chart

In the flow chart, the flow of water from 20°C is shown as a function of the positive pressure difference across the valve. The flow rate is expressed in liters per minute using a log scale and the pressure in bar.

Note: LP-series is not suitable for liquids.

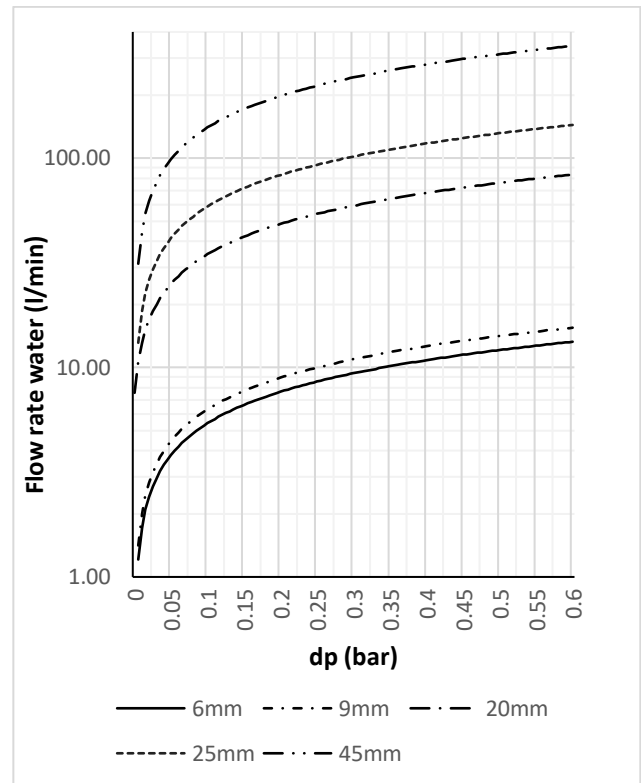

1.2. Duty cycle

The solenoid valve is suitable for continuous use. High switching frequencies and high pressures can reduce the lifespan.

1.3. Compliance

The coils are CE marked and comply with the LVD Directive (2006/95/EC) and EMC Directive (2004/108/EC), provided that the cables and connectors are properly connected.

1.4. Type label

The coil properties are displayed on a label on the coil. A second label is provided with the valve that shows all relevant valve parameters. This label must be attached to the other side of the coil. In the figure below, an example is shown.

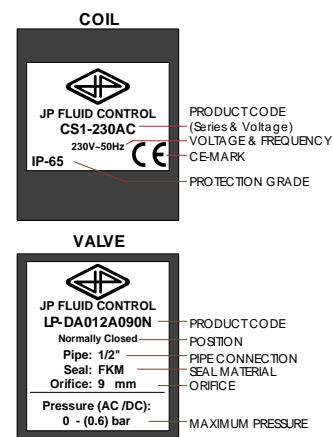

1.1. Exploded view

In the figure below an exploded drawing of the TW series is displayed.

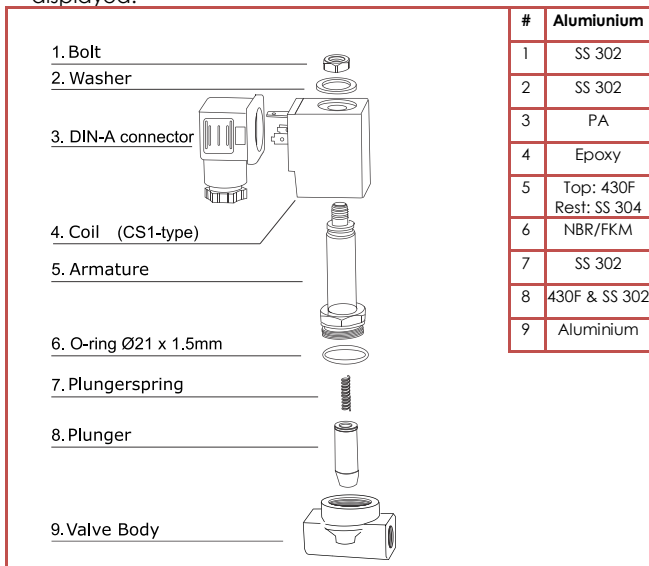

2. GENERAL SAFETY INSTRUCTIONS

- ▶ This product is not a safety device and may not be used as such.
- ▶ Damage caused by improper use, falling, improper operating conditions or other reasons, may cause improper functioning of the solenoid. Correct transport, proper storage and installation, and proper use and maintenance, are essential for reliable and error-free operation.
- ▶ It is the responsibility of the user to select the right product for the application.
- ▶ The product may not function properly as a result of dirt, wear, damage (for example, by dropping) or improper use. Therefore, the product should not be used in applications where a malfunction can cause danger or damage.
- ▶ This product is not intended or approved for medical applications, food and/or application in gas appliances.
- ▶ Solenoid valves can only be used with clean liquids or gases. It is recommended to install a filter before the solenoid valve.
- ▶ Check the compatibility of the medium used, temperature and other operating conditions with the materials and specifications of the product.
- ▶ Never exceed the limits for pressure, temperature or voltage as indicated on the product and/or in the technical documentation.
- ▶ The temperature of a solenoid valve coil can rise during operation; this is normal. Overheating will cause smoke and a burning smell. In this case, the power supply must immediately be disconnected.
- ▶ Warning: a valve opens and closes quickly. Improper use can cause pressure transients (fluid hammer) in the pipes with possible damage as a consequence.
- ▶ It is not allowed to change the construction of the valve.
- ▶ Beware of electric shock when working with electrical equipment.

3. INSTALLATION AND MAINTENANCE

1.1. Safety instructions before starting

- ▶ It is recommended to install the product in a dry environment. In moist environments, make sure that no moisture can penetrate the coil, actuator or connector. Install the solenoid valve in a safe way to avoid electric shock, burning or other injuries. Ensure that the solenoid valve is installed in an area with adequate ventilation to facilitate heat dissipation. Make sure the solenoid valve is not in contact with or in the vicinity of flammable materials. Ensure that the product is protected from frost. Frost may damage the product and/or block the moving parts, causing the product to malfunction.
- ▶ Operations may only be performed when the system is not pressurized, electrically disconnected and cooled down.
- ▶ Turn off the power supply before performing any work on the solenoid valve to prevent the risk of electrical shock and to prevent activation of the solenoid valve.
- ▶ The product is only safe when properly installed and operated by qualified persons. Please read the safety instructions and technical documentation carefully before installation, use or maintenance.
- ▶ Always make sure to start the installation safely after installation or maintenance.
- ▶ Water hammer is a typical consequence of a high flow rate and pressure in pipes with small diameters. There are several solutions to this problem:
 - ▶ Reduce the pressure with a pressure reducing valve before the solenoid valve.
 - ▶ Increase the pipe diameter if possible.
 - ▶ Dampen the water hammer by using a flexible hose or buffer before the solenoid valve.

1.2. Installation

Clean fluids and gases

The solenoid valve can be used in combination with clean neutral gases. Check if there is any dirt in the piping or valve before installing. It is recommended to install a filter (500 µm) before the solenoid valve.

Mounting the valve

Be aware of the direction of flow of the medium when installing the valve. Solenoid valves with an arrow on the housing must be connected in the indicated direction. The pipes on both sides of the valve must be securely fastened. Use a wrench for both valve and pipe while tightening to prevent unnecessary stresses in the system. The solenoid valve must be fixed via the provided connection points. Only exert force at the designated areas on the body such as the hexagon; never to the coil or armature. Avoid vibration in the pipes. Use a suitable sealant for threaded connections of the solenoid valve. Avoid the entry of thread sealing material in the valve, this can lead to malfunctioning of the valve.

Position

It is recommended to install the solenoid in vertical position with the coil facing upwards. This reduces the probability of the collection of debris in the solenoid valve. When the solenoid valve is mounted at an angle, it is recommended to deviate maximally 90° from the vertical position.

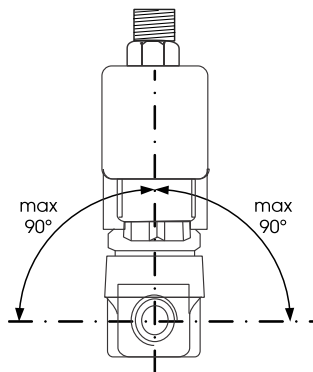

Maximum angle 90°.

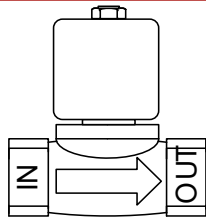

Check the flow direction with the help of the indications (numbers) on the valve body.

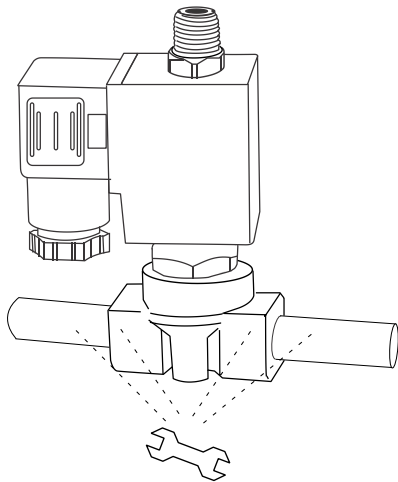

Only exert force at the designated faces, never at the coil or armature.

Installation of the coil

- ▶ Attach the label with the valve characteristics on the coil.
- ▶ The device can be damaged by the use of unsuitable tools.
- ▶ The temperature of the coil increases during use, this is normal. Overheating will cause smoke and a burning smell. In this case, the power supply must be shut down immediately.
- ▶ The coils can be rotated if the coil nut is loosened. After the determination of the correct position, the nut should be fastened with a torque of 5Nm.

Installation of the cable plug

- ▶ Always connect the ground (3), which is provided with a residual current device at voltages above 50V. Never use liquid or gas piping for grounding electrical equipment. The power supply is

connected to terminals (1) and (2). The polarity does not matter.

- ▶ Verify the voltage and frequency before connecting the coil.
- ▶ When mounting the connector, make sure that no moisture can ingress between the coil and connector. The connector screws should be fastened with a torque of 0.5Nm.

Connecting the power supply

- ▶ Never connect power to the coil when it is not attached to the solenoid valve! The coil may burn out.
- ▶ Only connect power if you are sure that there is no pressure in the system and no hazardous situations can occur.

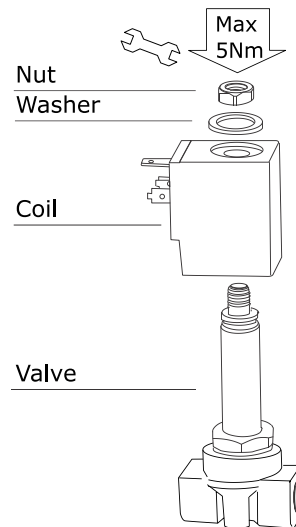

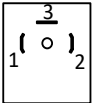

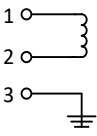

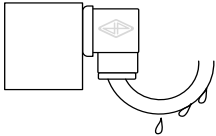

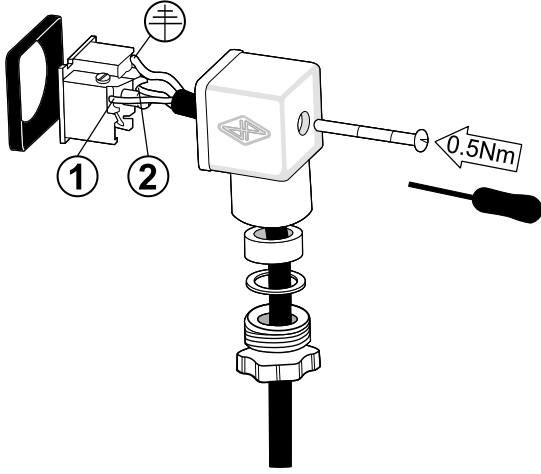

Connector: EN 175301-803 Type A (formerly DIN 43650A). The poles (1) and (2) should be connected to the power supply, polarity is not important. Pole (3) is the ground. Connect the connector thoroughly to avoid ingress of moisture. Ensure that drops cannot slip along the cable and enter the connector.

4. SPARE PARTS

The wear parts of the solenoid valve can be replaced with a repair kit (plunger, plunger spring, O-ring):

Product code	Circuit Function	Seal
LP-DA-A-REV	Normally closed	NBR
LP-DA-F-REV	Normally closed	FKM

The coil can be replaced. The product codes of the coil are shown in the table below:

Product code	Voltage
CS1-380AC	380V AC 50Hz
CS1-230AC	230V AC 50Hz
CS1-120AC	120V AC 60Hz
CS1-024AC	24V AC 50 Hz
CS1-012DC	12V DC
CS1-024DC	24V DC
CS2-380AC	380V AC 50Hz
CS2-230AC	230V AC 50Hz
CS2-120AC	120V AC 60Hz
CS2-024AC	24V AC 50 Hz
CS2-012DC	12V DC
CS2-024DC	24V DC

5. DISPOSAL

- The removal of the product should be performed in accordance with the applicable laws.