

Available with actuator function: **POWER OPEN - POWER CLOSE FAILSAFE MODULATING FAILSAFE MODULATING**

Feature rich **J+J** multi-voltage smart electric actuator with LED status light and function conversion kits.



Overview

The J3C-H300 high voltage electric valve actuator from the electric actuator manufacturer J+J offers an impressive list of standard features that include protection against damage from over-torque or condensation, safety features, the ability to have it's standard on-off function changed with user friendly plug & play conversion kits, and a highly visible LED light to offer users continual actuator operational status feedback.

The J3C Failsafe electric actuator is the same on-off J3C actuator but with a simple to install, user friendly 'BSR' failsafe function conversion kit. The J3C BSR failsafe actuator can be set to fail open or fail closed.

The J3C Modulating electric actuator is the same on-off J3C electric actuator but this time with the quick and easy to install 'DPS' modulating function conversion kit. The J3C DPS modulating actuator can be controlled by either a 4-20mA or 0-10V control signal and provides feedback as standard.

The LED light remains constantly lit if the actuator is able to respond to remote commands - if it can't, it flashes. The sequence of the flashes indicates what the reason may be for it being unable to respond.

J3C-H300 Electric Actuator Specifications

Voltage range - automatic sensing	85-240V AC (1ph) or DC
Digital Positioning System pre-installed	4-20mA or 0-10V I/O
Operating time (0-90° no load)	58 seconds
Maximum break torque	350 Nm (3097 lb.ins)
Maximum operating torque (run/ reseat)	300 Nm (2655 lb.ins)
Duty rating	75%
IP Rating (IEC 60529)	IP67
Working angle Standard (on request)	90° (180° or 270° options)
Mounting ISO:5211 x DIN 3337	F07 & F10 x 22 star (std)
Motor switches	2 x SPDT micro switches
End of travel confirmation (volt free)	2 x SPDT micro switches
Heater	3.5W
Ambient temperature range	-20° to +70°C (-4 to +158°F)
Electrical connecting plugs	DIN 43650/ ISO4400 & C192
Weight	5.2kg

J3C-L140 Consumption

110V AC	At maximum torque	0.61A (for power supply sizing x 2.5)
240V AC	At maximum torque	0.36A (for power supply sizing x 2.5)

How this J3C electric 1/4 turn modulating electric valve actuator works:

The rotational movement of the J3C modulating actuator is controlled by the DPS (Digital Positioning System), and creates movement proportional to the input control signal. The DPS PCB compares the physical position of the J3C actuator's output shaft, fed back via a potentiometer driven by the output shaft, to the input signal. If a difference exists between input (desired) and output (actual) positions, the DPS considers that an error and instructs the actuator's motor to turn in the direction and angular travel required to eliminate the difference. The J3C DPS from J+J is programmed to virtually eliminate hunting and once the desired input position is reached, it stops.

J3C Main features

IP67 Weatherproof, UV protected, corrosion resistant plastic housing.

LED light gives user continuous visual actuator status feedback - if the LED is flashing, there's a problem!

Many protective features as standard - such as over-torque and anti-condensation.

Multi-voltage capable, automatically sensed

Very user friendly and easy to install - all the electrical connections are external.

Unique plug & play function conversion kits create FAILSAFE & MODULATING function from a standard on-off electric actuator.

Available with actuator function: **POWER OPEN - POWER CLOSE FAILSAFE MODULATING FAILSAFE MODULATING**



Main features of the J3C electric actuator

IP67 Weatherproof, UV protected, corrosion resistant Polyamide housing.

IP67 allows the J3C electric actuator to be submerged, the international standard IEC60529 states: *Test duration is 30 minutes. Ingress of water in harmful quantity shall not be possible when the enclosure is immersed in water under defined conditions of pressure and time (up to 1 m of submersion). The lowest point of enclosures with a height less than 850 mm is located 1000 mm below the surface of the water, the highest point of enclosures with a height equal to or greater than 850 mm is located 150 mm below the surface of the water.*
The J3C is therefore fully weatherproof.

LED light gives user continuous visual actuator status feedback - if the LED is flashing, there's a problem!

The LED light provides a continuous highly visible indication of the J3C electric actuator's operational status. If all is well, the LED is solidly lit. If it is blinking there is a problem and the J3C will not respond to remote commands - the sequence gives an indication of the likely cause. The 2 most common are:

-  = Torque limiter has engaged (valve jammed?)
-  = Actuator is in 'manual' mode

Many protective features as standard - such as over-torque and anti-condensation.

Over-torque protection is electronic, the J3C constantly measures the current being drawn and compares it with pre-set parameters, if the current draw exceeds the parameter, the power is cut preventing mechanical damage to the actuator. An internal thermostatic heater, energised from the external power supplied to the power DIN connector, ensures the J3C's internal temperature remains above that at which condensation could form.

Multi-voltage capable, automatically sensed

The J3C-H300 valve actuator automatically senses the external power being applied and can accept any external voltage between 85 and 240V AC or DC.

Very user friendly and easy to install - all electrical connections are external.

J3C-H300 mounting options are ISO5211 F07 or F10 with a 22mm female star drive. Electrical connections are made using external DIN plugs supplied with the J3C actuator eliminating the need to remove the actuators cover to connect.

Unique plug & play function conversion kits create **FAILSAFE & MODULATING** function from a standard on-off electric actuator.

Uniquely, the J3C electric actuator can have it's standard on-off functionality changed by the installing of very user friendly plug and play function conversion kits. See the following page for more details

Manufactured in the EU by J+J

The J3C electric valve actuators are designed and manufactured by J+J in Spain. J+J have been designing and manufacturing electric actuators for over 25 years and the J+J valve actuators are sold in more than 30 countries.

J3C Series Smart Electric Actuator

Electrical Wiring Connections

Function options:

J3C ON-OFF ELECTRIC ACTUATOR

Standard function

Power open, power close. Stays put on loss of external power. Power remains on at all times.

J3C FAILSAFE ELECTRIC ACTUATOR

Fails to pre-set position on loss of external power

Power open, power close, fails to pre-set 'safe' position on loss of external power using internal industrial trickle charged rechargeable NiCad battery. Can be set to fail close (NC or normally closed) or fail open (NO or normally open) on loss of external power. The failsafe electric actuator moves to the position command applied at the time external power is restored.

In J+J electric actuators all electrical connections are made externally using the external DIN plugs supplied with the actuator. There is no need to remove the valve actuator's cover to connect electrically. There are no terminals internally to connect to.

J3C ON-OFF & FAILSAFE WIRING (Same connection for either)

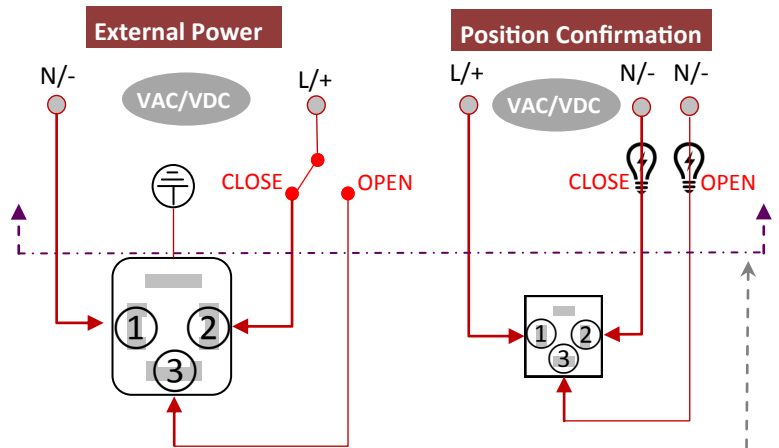

Note: Above line above is customer supplied

J3C MODULATING ELECTRIC ACTUATOR

Movement proportional to input signal

Power is applied continuously. Movement of valve actuator is then controlled by an internally fitted digital positioner and is proportional to changes supplied in an input control signal. This input signal is typically 0-10VDC, or 4-20mA. An output signal is supplied as standard providing closed loop control. Fails closed on loss of control signal (or see configuration options below), stays put on loss of external power.

Configuration options:

- 1) Closes on loss of control signal
- 2) Opens on loss of control signal
- 3) Stays put on loss of control signal

J3C MODULATING WIRING

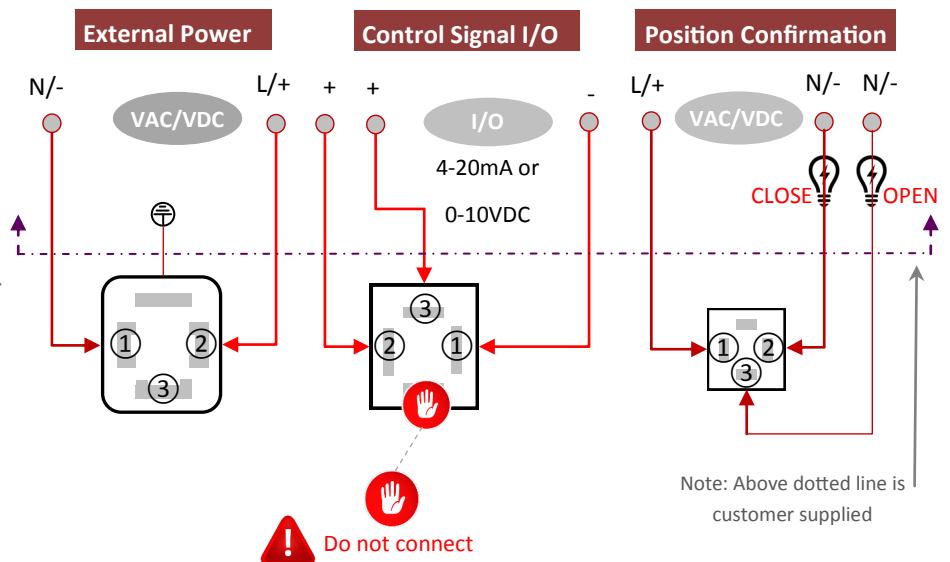

Note: Above dotted line is customer supplied

J3C FAILSAFE MODULATING ACTUATOR

Combination of failsafe & modulating kits above:

Uses battery failsafe system and digital positioner plug and play function conversion kits to provide fail to safe position function on loss of external power in a modulating application.

NOTE ON POWER SUPPLIES



It is imperative that the power supply has sufficient capacity to drive the J3C electric actuator. Ensure that safety factor of 3 is used to cover inrush on start-up, and for increased draw over time as the brushed DC motor wears.

J3C-300 DPS Dimensions

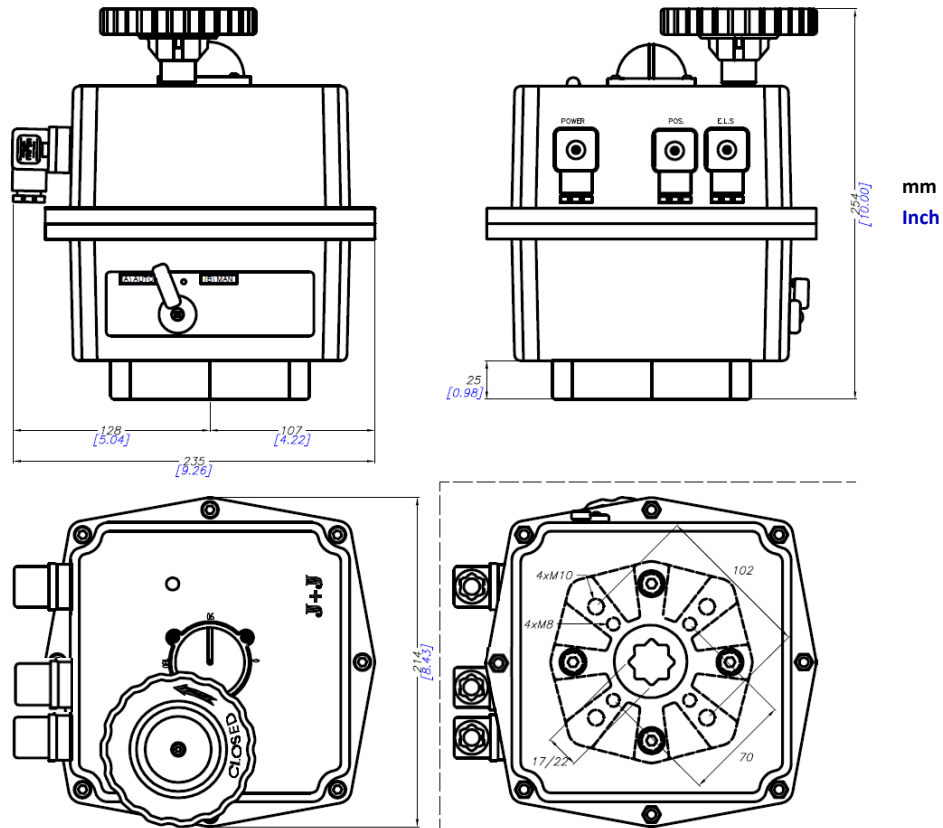

J3C Materials of construction:

Housing	Anti-corrosive Polyamide
Fasteners	Stainless steel
Gears	Polyamide (speed reducing) & steel
Shaft	Stainless steel
Output drive	Zamac
Position indicator	Clear Polyamide

J3C Plug & Play function conversion kits:

Failsafe and/or modulating function is quick and easy to achieve in the J3C smart electric actuator by the fitting of the user friendly failsafe and/or modulating plug & play function conversion kits to the standard on-off J3C smart valve actuator. When actuated valves are ordered with failsafe, modulating or failsafe modulating function, J+J install and test the plug and play function conversion kits. They can however easily be retro-fitted to J3C smart electric actuators should the on-off function requirement, supplied as standard, change.

Fitting both BSR & DPS plug and plug function conversion kits into the J3C creates failsafe modulating electric actuator.



DPS & BSR kits combined create a **J3C FAILSAFE MODULATING ELECTRIC ACTUATOR**

DPS + BSR



J3C MODULATINGACTUATOR WITH DPS PLUG & PLAY KIT INSTALLED

HOW THE DPS MODULATING SYSTEM WORKS

The rotational movement of the J3C modulating actuator is controlled by the DPS (Digital Positioning System), and creates movement proportional to the input control signal.

The DPS PCB compares the physical position of the J3C actuator's output shaft, fed back via a potentiometer driven by the output shaft, to the input signal. If a difference exists between input (desired) and output (actual) positions, the DPS considers that an error and instructs the actuator's motor to turn in the direction and angular travel required to eliminate the difference.

The DPS from J+J is programmed to virtually eliminate hunting and once the desired input position is reached, it stops.

Note: It is important that the control signals applied to the J3C modulating electric actuator are 'clean' and that a sensible deadband is set to prevent the DPS trying to constantly respond to changes in input signal. If this is likely to be problematic or difficult to control, we recommend installing a 2200µF capacitor across the 4-20mA input control signal terminals to act as a 'buffer'.

J3C 140/300 DPS SPECIFICATIONS

Model	J3C 140 & 300
Accuracy	3% F.S.
Linearity	2% F.S.
Hysteresis	3% F.S.
Points of resolution/ steps	70 in 90 degrees
4-20mA Impedance	100 Ω
0-10V Impedance	13 KΩ
Weight of installed DPS components	0.1kg

Available with actuator function: **POWER OPEN - POWER CLOSE FAILSAFE MODULATING FAILSAFE MODULATING**



J3C FAILSAFE ACTUATOR WITH BSR PLUG & PLAY KIT

HOW THE BSR FAILSAFE SYSTEM WORKS

The BSR plug and play FAILSAFE function conversion kit comprises 2 x NiCad industrial rechargeable battery packs, a PCB which in simplistic terms contains a system to trickle charge the batteries, to switch from external to battery power on the loss of external power and to initiate LED flashing sequences, and a jumper to plug into the PCB.

Once installed, the batteries are constantly trickle charged whenever external power is applied, maintaining them at full charge so that power is available to draw at the moment the external power fails. When the external power fails, the BSR PCB switches from external to internal power, and battery power is drawn to send the actuator to the pre-determined failsafe position, if not already in that position at the moment of loss of external power.

On resumption of external power, the J3C failsafe electric actuator will respect the command signal being applied at the moment the external power is restored. This may be different from the position seen at the moment of loss of external power.

J3C 140/300 BSR SPECIFICATIONS

	J3C-H140	J3C-L140	J3C-H300	J3C-L300
Number of operations possible with 100% charge of battery pack	2		1	
Minimum time to replace charge used in one battery movement	30mins		50 min	
Initial time required for 100% charge, before being put into service	27 hours			
Nominal battery capacity	1000mA			
Battery charge	37 mA/hr			
System to select fail closed, or fail open (see separate operating instructions)	Jumper on internal PCB			
Current draw from battery during operation	15.1mA		25.7mA	
Weight of BSR	0.4kg			

