

6.6.05 – Update with applications

Dual-duct units, electrical re-heater and radiator heating

A4 Application library CR24 V1.1 EN

Single room applications

CR



Layout

System - Application - Number										->						
I	R	C	-	V	A	V	-			IRC	VAV application					
I	R	C	-	V	A	V	-	0	0	1	1	.	0	IRC system	VAV	variant 0011.0
I	R	C	-	V	A	V	-	0	0	1	1	.	1	- sub-variant 0001.1		

Key

System - Application - Number										-> System		Application	
I	R	C	-	A	I	R	-			IRC	Air (damper)		
			-				-						
I	R	C	-	V	A	V	-			IRC	VAV		
			-				-						
I	R	C	-	W	A	T	-			IRC	Water		
			-				-						
I	R	C	-	C	L	C	-			IRC	Chilled/heated ceiling		
			-				-						
I	R	C	-	V	A	R	-			IRC	Various		

The application library consists of various single room applications based on the proofed Belimo actuators for motorized air and water applications and the new CR24 single room controller range. The applications are subdivided according to its system type.

The library is being updated regularly, please check for the latest issue: on the INTRANET or under www.belimo.ch

The detailed function description and technical data of the CR24 controller can be found in the CR24 Product-Information: www.belimo.ch

Air-Systems, pressure dependent

Application	Description	CR24 Type
IRC-AIR-0011.0	Single-duct – Damper control, Room temperature controlled – cooling mode	CR24-B1
IRC-AIR-0015.0	Single-duct – Damper control, with Change/over function	CR24-B1

VAV-Systems, pressure independent

Application	Description	CR24 Type
IRC-VAV-0011.0	VAV - Single-duct application, Room temperature controlled	CR24-B1
IRC-VAV-0011.1	VAV - Single-duct application, with Boost option: Temperature controlled	CR24-B3
IRC-VAV-0013.0	VAV – Dual duct application, with room temperature controller	new CR24-B1
IRC-VAV-0015.0	VAV - Single-duct application, Room temperature controlled with 0...10V reheat valve	CR24-B3
IRC-VAV-0015.1	VAV - Single-duct application, Room temperature controlled with 3-Point reheat valve	CR24-B2
IRC-VAV-0016.0	VAV - Single-duct application, Room temperature controlled with 1-stage electrical reheat	new CR24-B2E
IRC-VAV-0016.1	VAV - Single-duct application, Room temperature controlled with 2-stage electrical reheat	new CR24-B2E
IRC-VAV-0018.0	VAV - Single-duct application, Room temperature controlled with ON/OFF radiator valve	new CR24-B2E
IRC-VAV-0111.0	VAV - Single-duct application, with chilled ceiling	CR24-B3

Water applications

Application	Description	CR24 Type
IRC-WAT-0011.0	2-pipe system with 3-point reheat valve, Room temperature controlled	CR24-B2
IRC-WAT-0015.0	2-pipe system Heat exchanger, with Change/Over function	CR24-B1

Heat-/Chilled Ceiling-Systems

Application	Description	CR24 Type
IRC-CLC-0011.0	Chilled ceiling - 2-pipe-system, Room temperature controlled	CR24-B3
IRC-CLC-0015.0	Heat-/Chilled ceiling - 2-pipe-system, with Change-over function	CR24-B3

Air-Systems, pressure dependent

<i>Application</i>	<i>Description</i>	<i>CR24 Type</i>
IRC-AIR-0011.0	Single-duct – Damper control, Room temperature controlled – cooling mode	CR24-B1
IRC-AIR-0015.0	Single-duct – Damper control, with Change/over function	CR24-B1



Wiring diagram CR24-B1

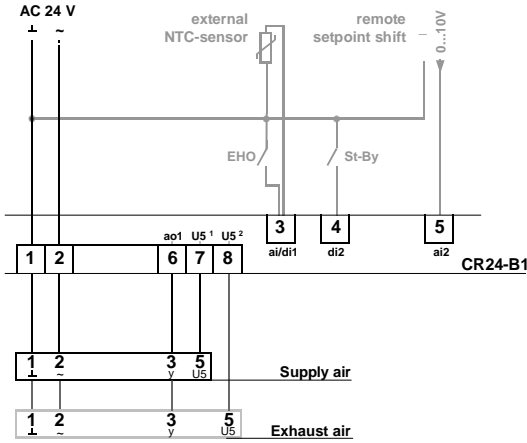

Mode setting actuator: 2...10V

In- & Output assignment

Inputs

- ai/di1 EHO / ext. Sensor *
- di2 Stand by *
- ai2 Remote setpoint shift *

Outputs

- ao1 System output (0)2...10V

* Optional

Note

The pin numbering corresponds to the Belimo actuator connections.

Refer to the CR24 Product-Information for technical data and detailed information.

Configuration, settings CR24-B1

DIP-Switch setting:

- 1 P-Band: normal - breit
- 2 di2: Stand by - Change over



Setpoint W_H range:

15...36 °C

Description, functional diagram

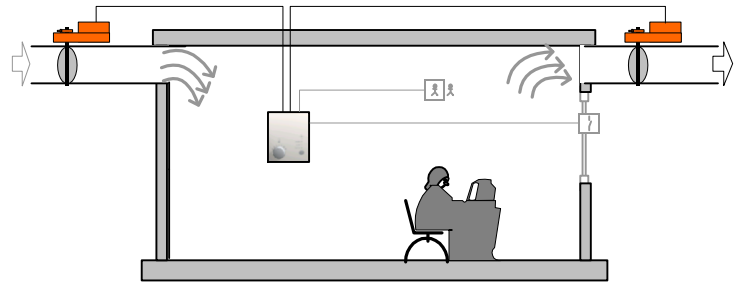

Pressure depending damper application. The room temperature aims as the demand related control value of the connected damper actuators.

Functional diagram

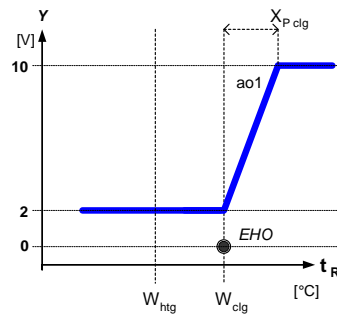

Hints

Mode setting damper: 2...10 V

Options

- ◆ di1 – EHO Energy hold off, e.g. window switch, ext. time switch
- ◆ di2 – Stand by, e.g. motion detector
- ◆ ai1 – external temperature sensing – exhaust duct
- ◆ ai2 – external setpoint shift, e.g. So/Wi-compensation

Operations - MMI

- CR24-A1 without user interface
- CR24-B1 with user interface

- Mode: AUTO
- Mode: AUTO-ECO-MAX

Air-System, pressure depending

IRC-AIR-0015.0

Single duct – Damper control,
with Change/Over function



Wiring diagram CR24-B1

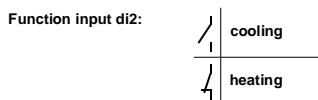
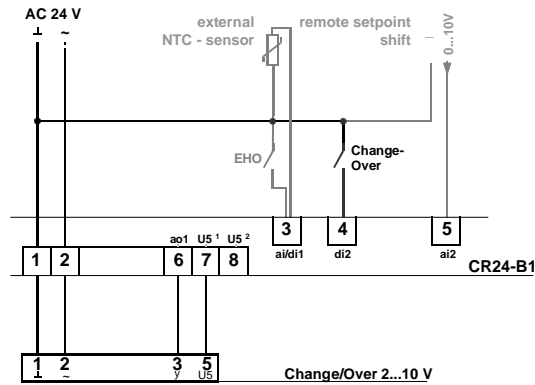

In- & Output assignment

Inputs

- ai/di1 EHO / ext. Sensor *
- di2 **Change/Over**
- ai2 Remote setpoint shift *

Outputs

- ao1 **Change/over actuator 2...10V**

* Optional

Note

The pin numbering corresponds to the Belimo actuator connections.

Refer to the CR24 Product-Information for technical data and detailed information.

Configuration, setting CR24-B1

DIP-Switch setting:

- 1 P-Band: normal - wide
- 2 di2: Stand by - **Change over**



Setpoint W_H range:

15...36 °C

Description, functional diagram

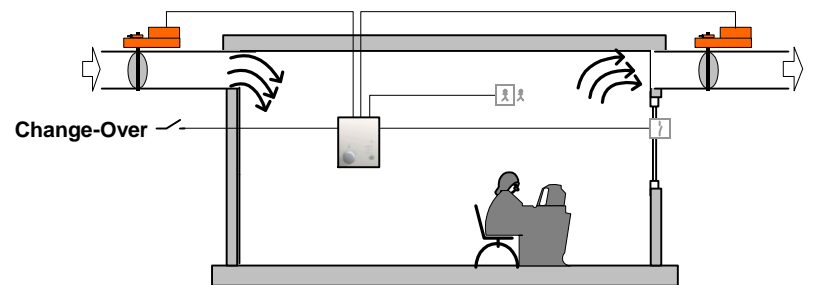

Pressure depending single-duct damper application with Change/Over-function heating - cooling. Change/over Heating \leftrightarrow cooling switching action via dry contact depending e.g. via the temperature of the supply system.

Functional diagram

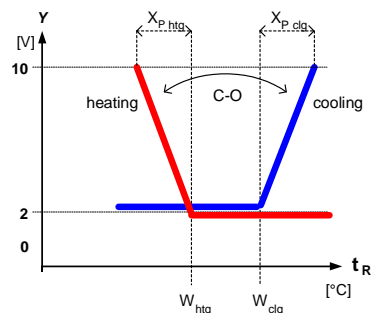

Hint

Mode setting actuator: 2...10 V

Options

- ◆ di1 – EHO Energy hold off, e.g. window switch, ext. timeswitch
- ◆ ai1 – external temperature sensing – exhaust duct
- ◆ ai2 – external setpoint shift, e.g. So/Wi-compensation

Bedienung

- CR24-A1 without user interface Mode: *AUTO*
- CR24-B1 with user interface Mode: *AUTO-ECO-MAX*

VAV-Systems, pressure independent

<i>Application</i>	<i>Description</i>	<i>CR24 Type</i>
IRC-VAV-0011.0	VAV - Single-duct application, Room temperature controlled	CR24-B1
IRC-VAV-0011.1	VAV - Single-duct application, with Boost option: Temperature controlled	CR24-B3
IRC-VAV-0013.0	VAV – Dual duct application, with room temperature controller	new CR24-B1
IRC-VAV-0015.0	VAV - Single-duct application, Room temperature controlled with 0...10V reheater valve	CR24-B3
IRC-VAV-0015.1	VAV - Single-duct application, Room temperature controlled with 3-Point reheater valve	CR24-B2
IRC-VAV-0016.0	VAV - Single-duct application, Room temperature controlled with 1-stage electrical reheater	new CR24-B2E
IRC-VAV-0016.1	VAV - Single-duct application, Room temperature controlled with 2-stage electrical reheater	new CR24-B2E
IRC-VAV-0018.0	VAV - Single-duct application, Room temperature controlled with ON/OFF radiator valve	new CR24-B2E
IRC-VAV-0111.0	VAV - Single-duct application, with chilled ceiling	CR24-B3



Wiring diagram CR24-B1

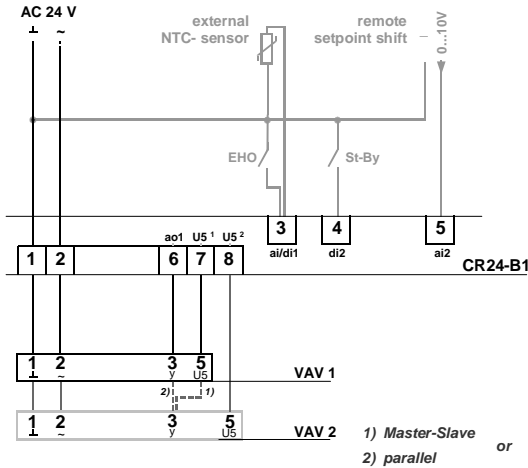

Mode setting VAV-controller: 2...10V

In- & Output assignment

Inputs

- ai/di1 EHO / ext. Sensor *
- di2 Stand by *
- ai2 Remote setpoint shift *

Outputs

- ao1 VAV system output (0)2...10V

* Optional

Note

The pin numbering corresponds to the Belimo actuator connections.

Refer to the CR24 Product-Information for technical data and detailed information.

Configuration, settings CR24-B1

DIP-Switch setting:

- 1 P-Band: normal - wide
- 2 di2: Stand by - Change over



Setpoint W_H range:

15...36 °C

Description, functional diagram

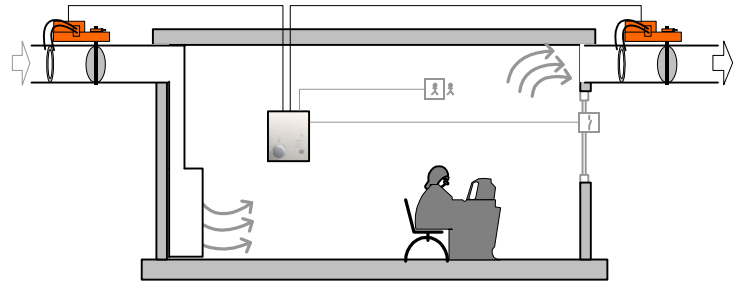

The room temperature aims as the demand related control value of the connected VAV units. The variable volumetric flow range $V'_{min}...V'_{max}$ equals to:

- V'_{min} - to the hygienic air change
- V'_{max} - to the maximum cooling demand.

Functional diagram

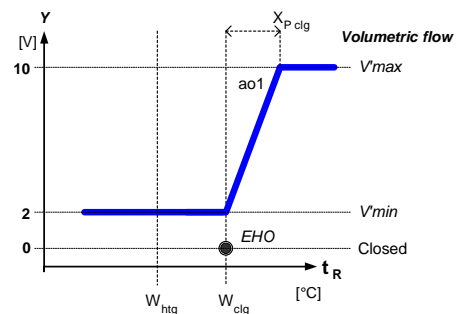

Hints

Application requires VAV - controller mode setting: 2...10 V

Options

- ◆ di1 – EHO Energy hold off, e.g. window switch, ext. timeswitch
- ◆ di2 – Stand by, e.g. motion detector
- ◆ ai1 – external temperature sensing – exhaust duct
- ◆ ai2 – external setpoint shift, e.g. So/Wi-compensation

Operations - MMI

- | | | |
|---------|------------------------|---------------------------|
| CR24-A1 | without user interface | Mode: <i>AUTO</i> |
| CR24-B1 | with user interface | Mode: <i>AUTO-ECO-MAX</i> |



Wiring diagram CR24-B3

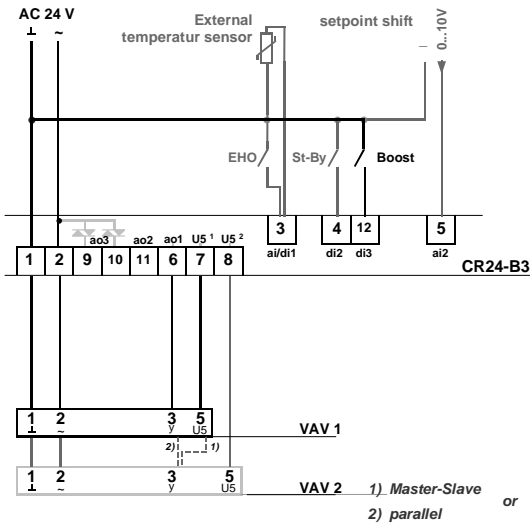

Mode setting VAV-controller: 2...10V

In- & Output assignment

Inputs

- ai/di1 EHO / ext. Sensor *
- di2 Stand by *
- di3 **Boost**
- ai2 Remote setpoint shift *

Outputs

- ao1 **VAV system output (0)2...10V**

* Optional

Note

The pin numbering corresponds to the Belimo actuator connections.

Refer to the CR24 Product-Information for technical data and detailed information.

Configuration, settings CR24-B3

DIP-Switch setting:

- 1 P-Band: **normal** - wide
- 2 V_{max} Hz: **Off** - 80%
- 3 ao2: **heating** - cooling/C-O
- 4 di3: **Boost** - Dewpoint/C-O
- 5 Boost: **Temp.** - V_{max}
- 6 controller: **PI** - P



Setpoint W_H range:

15...36 °C

Description, functional diagram

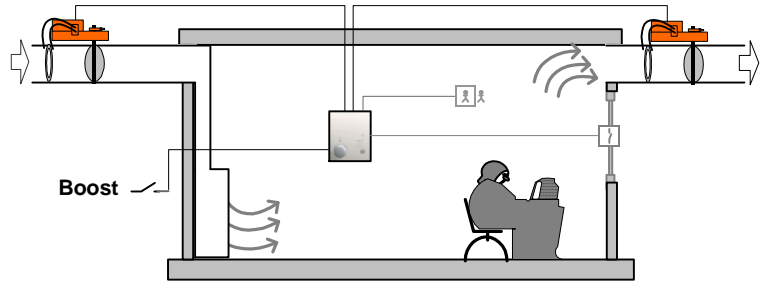

The room temperature aims as the demand related control value of the connected VAV units. The variable volumetric flow range V_{min}...V_{max} equals to: hygienic air change ... maximum cooling demand.

Room preconditioning can be triggered via Boost input di3, e.g. via external timer, building management system.

Function „Boost Temperature controlled“

- ON: di3 active -> VAV output ao1 10 V (V_{max})
- OFF: di3 inactive or comfort setpoint reached -> Auto operation

Functional diagram

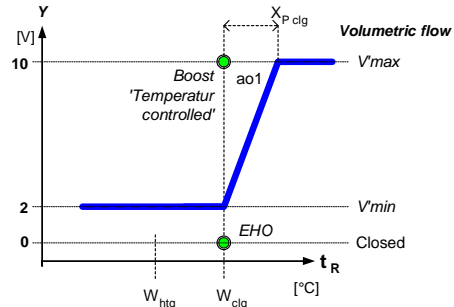

Hints

Application requires VAV - controller mode setting: 2...10 V

Options

- ◆ di1 – EHO Energy hold off, e.g. window switch, ext. timeswitch
- ◆ di2 – Stand by, e.g. motion detector
- ◆ ai1 – external temperature sensing – exhaust duct
- ◆ ai2 – external setpoint shift, e.g. So/Wi-compensation

Operations - MMI

- CR24-A3 without user interface Mode: *AUTO*
- CR24-B3 with user interface Mode: *AUTO-ECO-MAX*



Wiring diagram CR24-B1

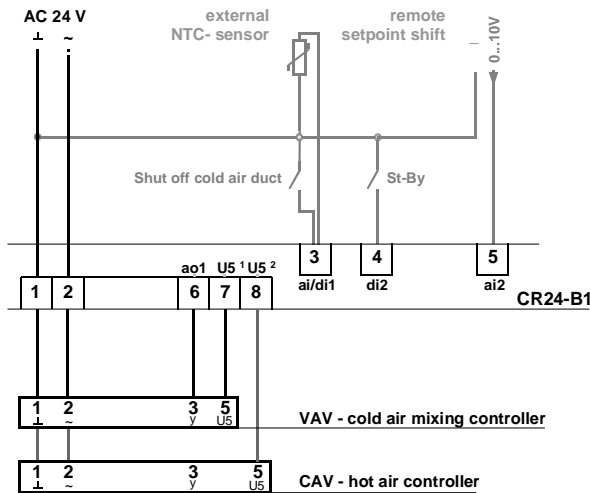

Mode setting VAV-controller: 2...10V

In- & Output assignment

Inputs

- ai/di1 ext. Sensor * / Shut-off cold air duct *
- di2 St-By Stand by *
- ai2 Remote setpoint shift *

Outputs

- ao1 VAV system output (0)2...10V

* Optional

Note

The pin numbering corresponds to the Belimo actuator connections

Refer to the CR24 Product-Information for technical data and detailed information.

Configuration, settings CR24-B1

DIP-Switch setting:

- 1 P-Band: **normal** - wide
- 2 di2: **Stand by** - Change over



Setpoint W_H range:

15...36 °C

Description, functional diagram

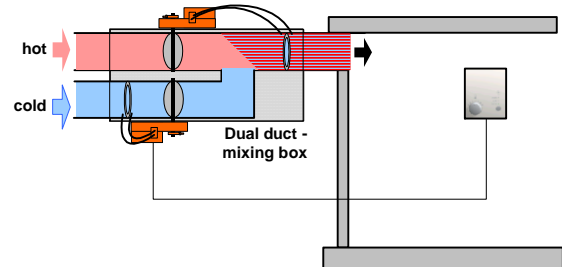

The cold and the hot air supplied by the dual duct system get mixed by the two volume controller according to the required room demand.

The hot air constant volume (CAV) controller is supporting the required hot air for the heating condition. At cooling demand the cold air (VAV) controller adds the cold air part as required by the CR24 room temperature controller. In case the cold air parts exceeds the hot air part, the hot air damper gets closed and the cold air supply is in work only.

Option:

The cold air duct can be shut-off by the use of a switch contact connected to input di1.

Functional diagram

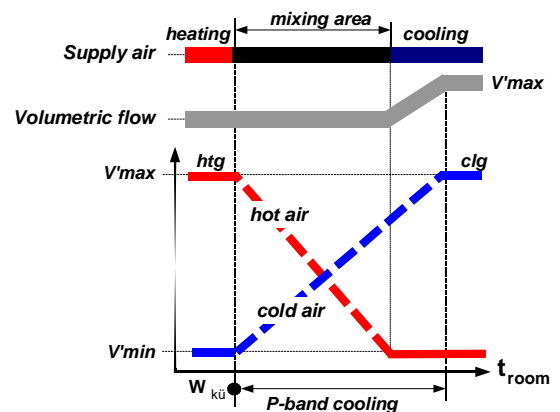

Hints

Application requires VAV - controller mode setting: 2...10 V

Options

- ♦ di1 – Shot off cold air duct, e.g. ext. time switch
- ♦ di2 – Stand by, e.g. motion detector
- ♦ ai1 – external temperature sensing – exhaust duct
- ♦ ai2 – external setpoint shift, e.g. So/Wi-compensation

Operations - MMI

CR24-A1	without user interface	Mode: AUTO
CR24-B1	with user interface	Mode: AUTO-ECO-MAX



Wiring diagram CR24-B3

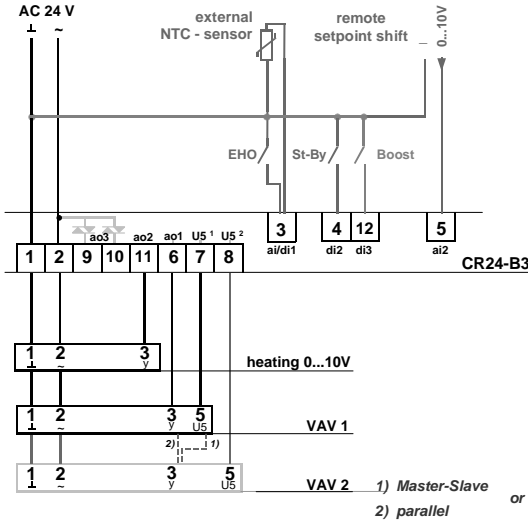

Hint: Mode setting VAV controller: 2...10V

In- & Output assignment

Inputs

- ai/di1 EHO / ext. Sensor *
- di2 Stand by *
- di3 Boost *
- ai2 Remote setpoint shift *

Outputs

- ao1 VAV system output (0)2...10V
- ao3 Heating output 3-point

* Optional

Note

The pin numbering corresponds to the Belimo actuator connections.

Refer to the CR24 Product-Information for technical data and detailed information.

Configuration, settings CR24-B3

DIP-Switch setting:

- 1 P-Band: **normal** - wide
- 2 V_{max} Hz: Off - **80%**
- 3 ao2: **heating** - cooling/C-O
- 4 di3: **Boost** - Dewpoint/C-O
- 5 Boost: **Temp** - V_{max}
- 6 controller: **PI** - P



Setpoint W_H range:

15...36 °C

Description, functional diagram

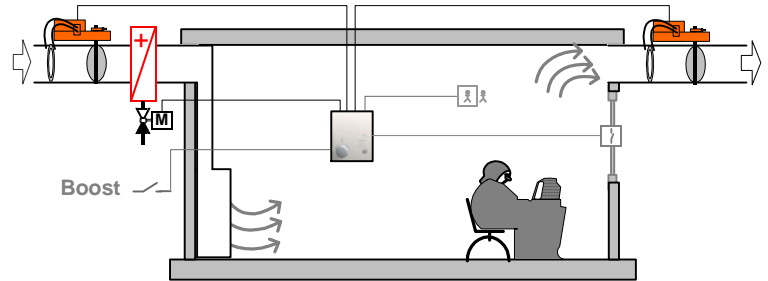

The room temperature aims as the demand related control value of the connected VAV units. The variable volumetric air flow range V_{min}...V_{max} equals to:

- V_{min} - to the hygienic air change
- V_{max} - to the maximum cooling demand.

The reheater gets controlled via the connected 0...10 V valve at heating request. To ensure the required airflow over the reheater the volumetric air flow gets controlled V_{min}.... 80% V_{max} during that condition.

Option:

Digital input di3 driven by a Boost signal allows the preconditioning of the room. Two Boost modes can be used:

- Boost – 'Temperature controlled': quick-heating and/or, -cooling
- Boost – V_{max}: room flush, support smoke extraction

Functional diagram

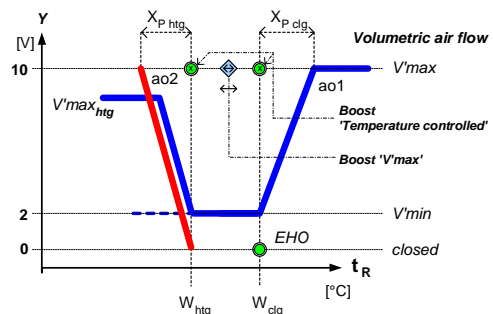

Hints

- Application requires VAV - controller mode setting: 2...10 V
- Heating output ao2: 0...10 V

Options

- ◆ di1 – EHO Energy hold off, e.g. window switch, ext. time switch
- ◆ di2 – Stand by, e.g. motion detector
- ◆ di3 – Boost, e.g. BMS, ext. time switch
- ◆ ai1 – external temperature sensing – exhaust duct
- ◆ ai2 – external setpoint shift, e.g. So/Wi-compensation

Operations - MMI

- CR24-A3 without user interface Mode: *AUTO*
- CR24-B3 with user interface Mode: *AUTO-ECO-MAX*



Wiring diagram CR24-B2

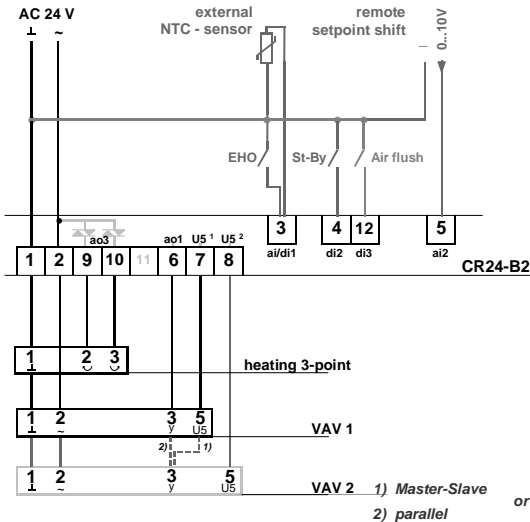

Hint: Mode setting VAV-controller: 2...10V

In- & Output assignment

Inputs

- ai/di1 EHO / ext. Sensor *
- di2 Stand by *
- di3 Air flush *
- ai2 Remote setpoint shift *

Outputs

- ao1 VAV system output (0)2...10V
- ao3 Heating output 3-point

* Optional

Note

The pin numbering corresponds to the Belimo actuator connections.

Refer to the CR24 Product-Information for technical data and detailed information.

Configuration, settings CR24-B2

DIP-Switch setting:

- 1 P-Band: **normal** - wide
- 2 Vmax htg Off - **80%**



Setpoint W_H range:

15...36 °C

Description, functional diagram

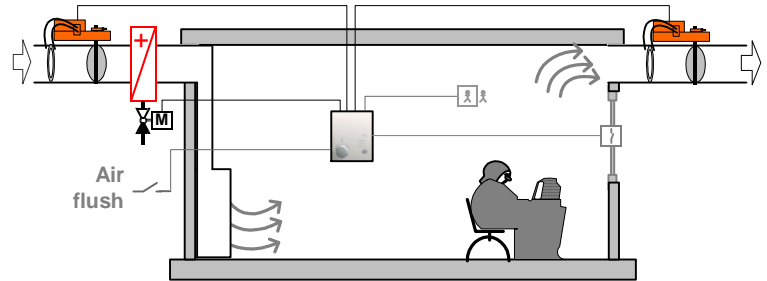

The room temperature aims as the demand related control value of the connected VAV units. The variable volumetric air flow range $V'_{min}...V'_{max}$ equals to:

- V'_{min} - to the hygienic air change
- V'_{max} - to the maximum cooling demand.

A reheater gets activated via the connected 3-point valve at heating request. To ensure the required airflow over the reheater the volumetric air flow gets controlled $V'_{min}...80\% V'_{max}$ during that condition.

Option:

The VAV-application can be forced to the ' V'_{max} ' step by the use of the digital input di3. Typical use air flush via an independent air quality control loop, support of smoke extraction, etc. The heating output does not get influenced during that condition.

Functional diagram

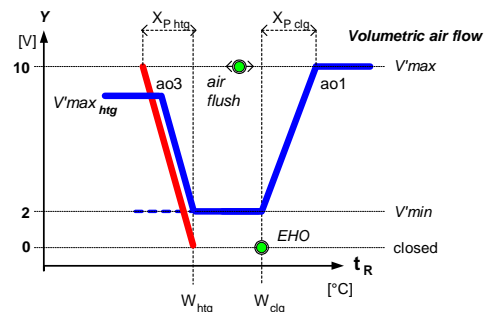

Hints

- Application requires VAV - controller mode setting: 2...10 V
- Heating output ao3: 3-point actuator, optimized for 150 s running time

Options

- ◆ di1 – EHO Energy hold off, e.g. window switch, ext. time switch
- ◆ di2 – Stand by, e.g. motion detector
- ◆ di3 – Air flush, e.g. air quality control, ext. time switch
- ◆ ai1 – external temperature sensing – exhaust duct
- ◆ ai2 – external setpoint shift, e.g. So/Wi-compensation

Operations - MMI

- CR24-A2 without user interface Mode: *AUTO*
- CR24-B2 with user interface Mode: *AUTO-ECO-MAX*



Wiring diagram CR24-B2E

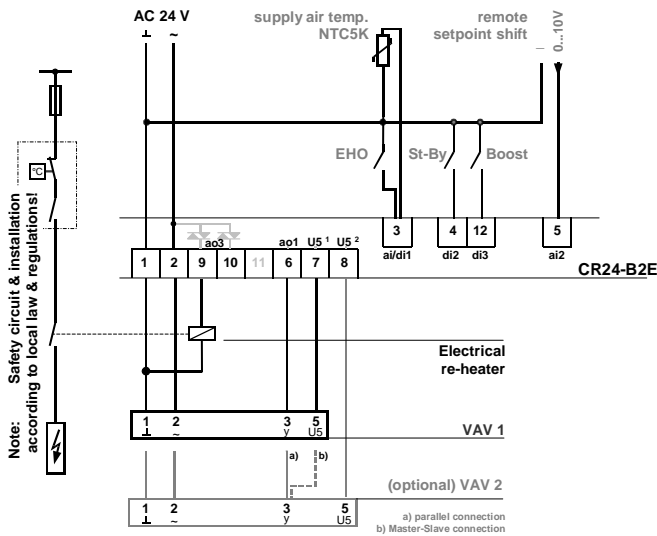

In- & Output assignment

Inputs

- ai/di1 supply air limitation * / EHO *
- di2 Stand by *
- di3 Boost *
- ai2 Remote setpoint shift *

Outputs

- ao1 VAV system output (0)2...10V
- do3/1 Heating output 24 VAC ON/OFF

* Optional

Note

The pin numbering corresponds to the Belimo actuator connections.

Refer to the CR24 Product Information and the data sheet CR24-B2E for technical data and detailed information..

Configuration, settings CR24-B2E

DIP-Switch setting:

- 1 Steps: **1 or 2** - binary
- 2 V^{max} Htg: Off - **80%**



Setpoint W_H range:

15...36 °C

Description, functional diagram

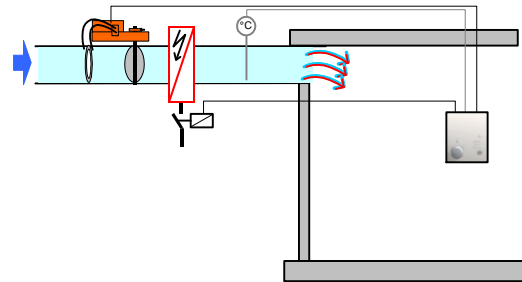

The room temperature aims as the demand related control value of the connected VAV units. The variable volumetric air flow range $V'_{min}...V'_{max}$:

- V'_{min} - to the hygienic air change
- V'_{max} - to the maximum cooling demand.

At heating conditions the reheater gets controlled via the ON/OFF Triac-output. The volumetric flow gets increased 35 ... 80% V'_{max} to ensure the thermal transfer.

Options:

By the use of an external sensor mounted in the supply duct the air injection temperature can be limited to a maximum of about 50°C.

Functional diagram

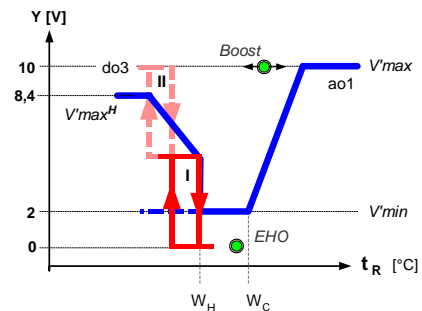

Hints

- Application requires VAV - controller mode setting: 2...10 V

Options

- ♦ di1 – EHO Energy hold off, e.g. window switch, ext. time switch
- ♦ di2 – Stand by, e.g. motion detector
- ♦ di3 – Boost, e.g. BMS, ext. time switch
- ♦ ai1 – Supply air limitation, NTC5k sensor
- ♦ ai2 – external setpoint shift, e.g. So/Wi-compensation

Operations - MMI

CR24-A2E without user interface Mode: **AUTO**

CR24-B2E with user interface Mode: **AUTO-ECO-MAX**



Wiring diagram CR24-B2E

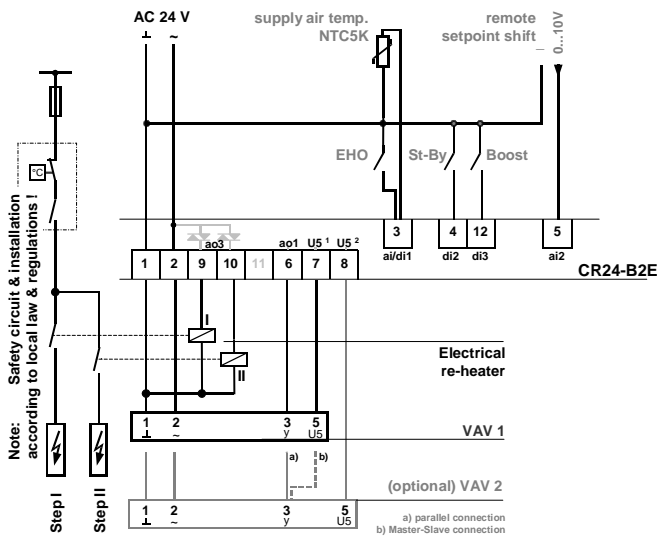

In- & Output assignment

Inputs

- ai/di1 supply air limitation * / EHO *
- di2 Stand by *
- di3 Boost *
- ai2 Remote setpoint shift *

Outputs

- ao1 VAV system output (0)2...10V
- do3/1 Heating output I 24 VAC ON/OFF
- do3/2 Heating output II 24 VAC ON/OFF

* Optional

Note

The pin numbering corresponds to the Belimo actuator connections.

Refer to the CR24 Product-Information and the data sheet CR24-B2E for technical data and detailed information..

Configuration, settings CR24-B2E

DIP-Switch setting:

- 1 Steps: 1 or 2 - **binary**
- 2 V^{max} Htg: Off - **80%**



Setpoint W_H range:

15...36 °C

Description, functional diagram

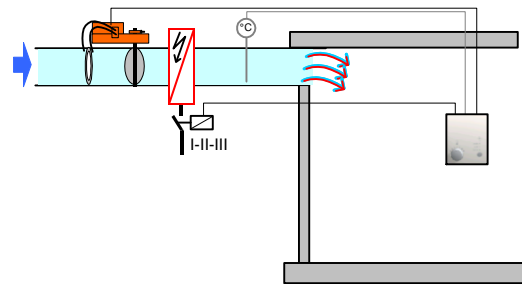

The room temperature aims as the demand related control value of the connected VAV units. The variable volumetric air flow range V[']min...V[']max:

- V[']min - to the hygienic air change
- V[']max - to the maximum cooling demand.

At heating conditions the 2-step re-heater gets controlled via the two ON/OFF Triac-outputs in a binary mode which gives an almost modulating control mode. The volumetric flow gets increased 35 ... 80% V[']max to ensure the thermal transfer.

Options:

By the use of an external sensor mounted in the supply duct the air injection temperature can be limited to a maximum of about 50°C.

Functional diagram

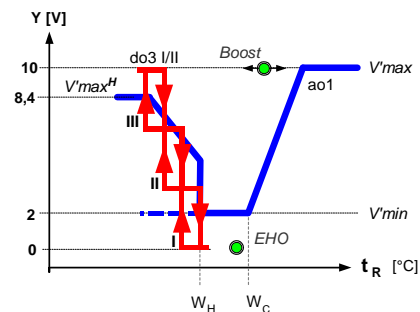

Hints

- Application requires VAV - controller mode setting: 2...10 V

Options

- ♦ di1 – EHO Energy hold off, e.g. window switch, ext. time switch
- ♦ di2 – Stand by, e.g. motion detector
- ♦ di3 – Boost, e.g. BMS, ext. time switch
- ♦ ai1 – Supply air limitation, NTC5k sensor
- ♦ ai2 – external setpoint shift, e.g. So/Wi-compensation

Operations - MMI

CR24-A2E without user interface Mode: **AUTO**

CR24-B2E with user interface Mode: **AUTO-ECO-MAX**



Wiring diagram CR24-B2E

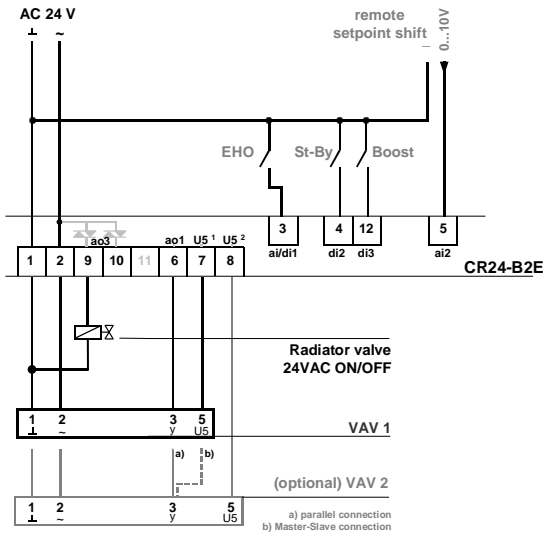

In- & Output assignment

Inputs

- di1 EHO *
- di2 Stand by *
- di3 Boost *
- ai2 Remote setpoint shift *

Outputs

- ao1 VAV system output (0)2...10V
- do3/1 Heating output 24 VAC ON/OFF

* Optional

Note

The pin numbering corresponds to the Belimo actuator connections.

Refer to the CR24 Product-Information and the data sheet CR24-B2E for technical data and detailed information.

Configuration, settings CR24-B2E

DIP-Switch setting:

- 1 Steps: 1 or 2 - binary
- 2 V/max Htg: Off - 80%



Setpoint W_H range:

15...36 °C

Description, functional diagram

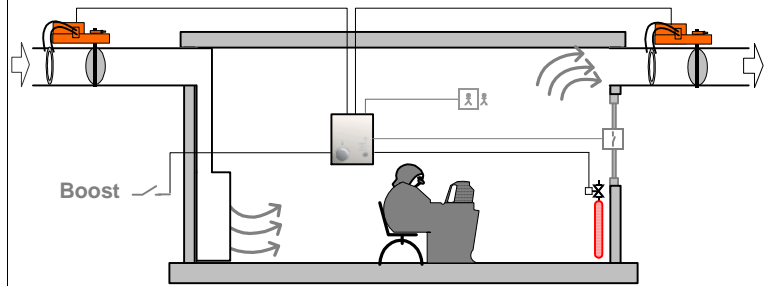

The room temperature aims as the demand related control value of the connected VAV units. The variable volumetric air flow range $V'min...V'max$:

- $V'min$ - to the hygienic air change
- $V'max$ - to the maximum cooling demand.

At heating conditions the ON/OFF radiator valve gets controlled via the CR24 Triac-output.

Functional diagram

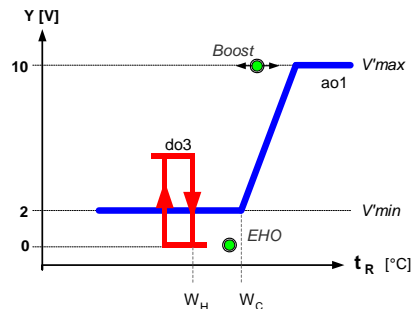

Hints

- Application requires VAV - controller mode setting: 2...10 V

Options

- ◆ di1 – EHO Energy hold off, e.g. window switch, ext. time switch
- ◆ di2 – Stand by, e.g. motion detector
- ◆ di3 – Boost, e.g. BMS, ext. time switch
- ◆ ai2 – external setpoint shift, e.g. SoWi-compensation

Operations - MMI

CR24-A2E without user interface Mode: *AUTO*
 CR24-B2E with user interface Mode: *AUTO-ECO-MAX*



Wiring diagram CR24-B3

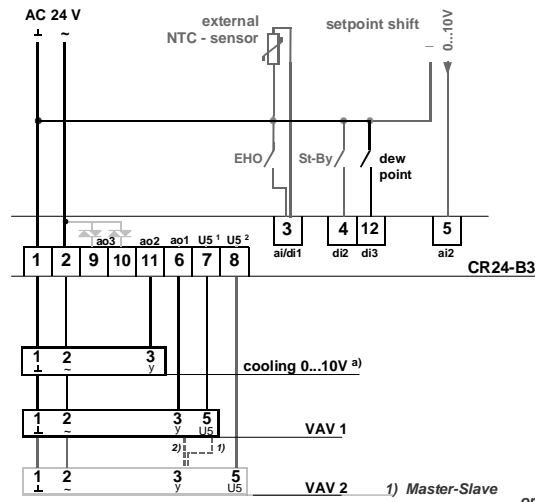

Mode setting VAV controller: 2...10V ^{a)}

a) control signal input needs to be adjusted in case of unit sequencing

Function Dew point control: $\left. \begin{array}{l} \nearrow \\ \searrow \end{array} \right\} \begin{array}{l} \text{cooling} \\ \text{Dew point undershot} \end{array}$

In- & Output assignment

Inputs

- ai/di1 EHO / ext. Sensor *
- di2 Stand by *
- di3 Dew point control
- ai2 Remote setpoint shift *

Outputs

- ao1 VAV system output (0)2...10V
- ao3 Cooling output 0...10V

* Optional

Note

The pin numbering corresponds to the Belimo actuator connections.

Refer to the CR24 Product-Information for technical data and detailed information.

Configuration, settings CR24-B3

DIP-Switch setting:

- 1 P-Band: **normal** - wide
- 2 V_{max} Hz: **Off** - 80%
- 3 ao2: heating - **cooling/C-Q**
- 4 di3: Boost - **Dewpoint/C-Q**
- 5 Boost: **Temp.** - V_{max}
- 6 controller: **PI** - P

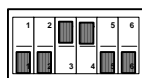

Setpoint W_H range:

15...36 °C

Description, functional diagram

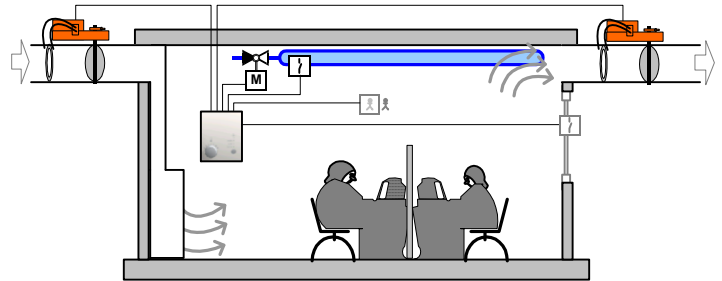

The room temperature aims as the demand related control value of the connected VAV units and chilled ceiling. The variable volumetric air flow range V_{min}...V_{max} equals to: hygienic air change ... maximum cooling demand.

Option – unit sequencing:

The two cooling units can also be used in control sequencing:

Unit 1 - Chilled ceiling: 0 ... 5 V (MFT-actuator)

Unit 2 - VAV: 5 ...10 V (MFT-controller. E.g. NMV-D2M)

Functional diagram

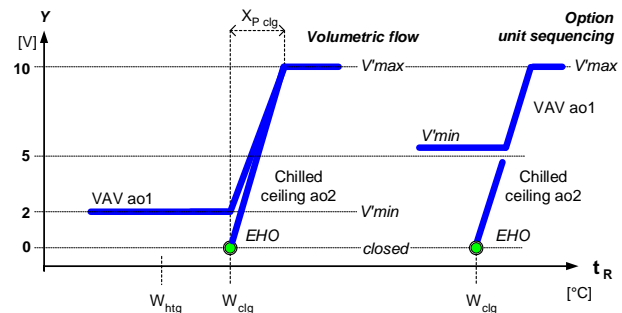

Hints

- Application requires VAV - controller mode setting: 2...10 V
- Cooling output 0 ... 10 V

By the use of the control sequencing option the control input of the MFT-actuators need to be adjusted (PC-Tool or MFT-Handy)

Options

- ◆ di1 – EHO Energy hold off, e.g. window switch, ext. time switch
- ◆ di2 – Stand by, e.g. motion detector
- ◆ ai1 – external temperature sensing – exhaust duct
- ◆ ai2 – external setpoint shift, e.g. So/Wi-compensation

Operations - MMI

CR24-A3 without user interface

Mode: *AUTO*

CR24-B3 with user interface

Mode: *AUTO-ECO-MAX*

Water applications

<i>Application</i>	<i>Description</i>	<i>CR24 Type</i>
IRC-WAT-0011.0	2-pipe system with 3-point reheater valve, Room temperature controlled	CR24-B2
IRC-WAT-0015.0	2-pipe system Heat exchanger, with Change/Over function	CR24-B1



Wiring diagram CR24-B2

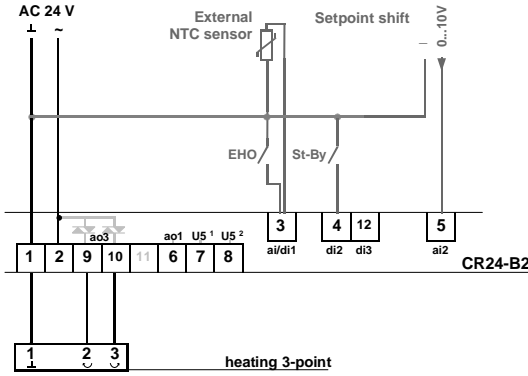

Description, functional diagram

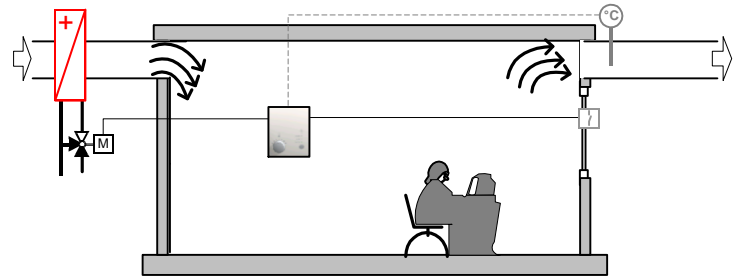

Energy demand controlled reheater application, based on the room temperature.

In- & Output assignment

Inputs

- ai/di1 EHO / ext. Sensor *
- di2 St-By Standby *
- ai2 Remote setpoint shift *

Outputs

- ao1 Heating valve 3-point

* Optional

Note

The pin numbering corresponds to the Belimo actuator connections.

Refer to the CR24 Product-Information for technical data and detailed information.

Configuration, settings CR24-B2

DIP-Switch setting:

- 1 P-Band: **normal** - wide
- 2 V_{max} htg **Off** - 80%



Setpoint W_H range:

15...36 °C

Functional diagram

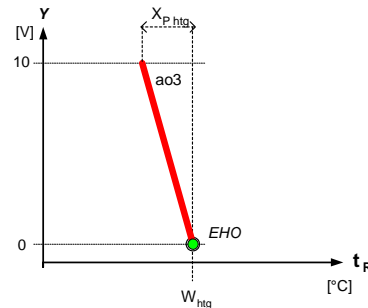

Hint

Heating output ao3: 3-point actuator, optimized for 150s running time

Options

- ◆ di1 – EHO Energy hold off, e.g. window switch, ext. timeswitch
- ◆ ai1 – external temperature sensing – exhaust duct
- ◆ ai2 – external setpoint shift, e.g. So/Wi-compensation

Operations - MMI

CR24-A2 without user interface

Mode: **AUTO**

CR24-B2 with user interface

Mode: **AUTO-ECO-MAX**



Wiring diagram CR24-B1

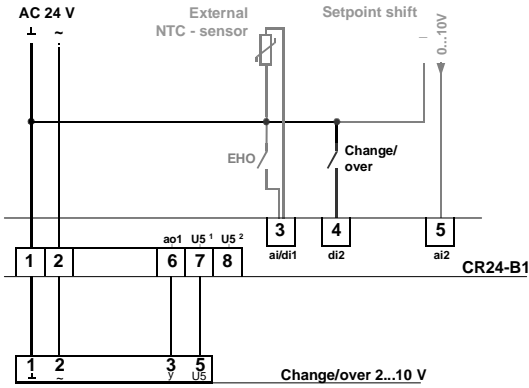

In- & Output assignment

Inputs

- ai/di1 EHO / ext. Sensor *
- di2 Change/over signal
- ai2 Remote setpoint shift *

Outputs

- ao1 Change/over actuator 2...10V

* Optional

Note

The pin numbering corresponds to the Belimo actuator connections.

Refer to the CR24 Product-Information for technical data and detailed information.

Configuration, settings CR24-B1

DIP-Switch setting:

- 1 P-Band: normal - wide
- 2 di2: Stand by - Change over



Setpoint W_H range:

15...36 °C

Description, functional diagram

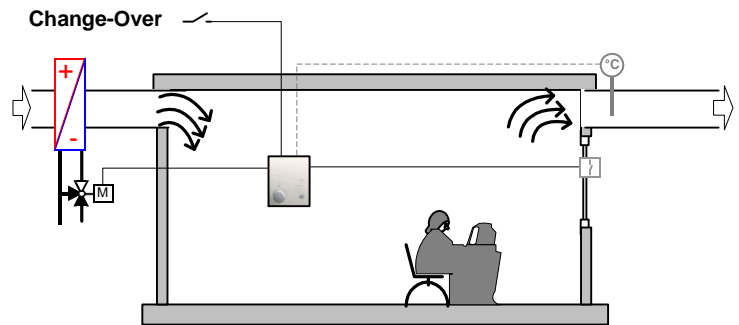

2-pipe demand controlled application supporting Change/over operation. Heating \leftrightarrow cooling switching action via a dry contact depending e.g. on the flow temperature of the supply system.

Functional diagram

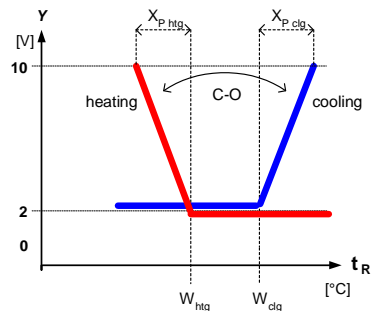

Hint

Actuator setting: 2...10 V

Options

- ◆ di1 – EHO Energy hold off, e.g. window switch, ext. timeswitch
- ◆ ai1 – external temperature sensing – exhaust duct
- ◆ ai2 – external setpoint shift, e.g. So/Wi-compensation

Operations - MMI

- CR24-A1 without user interface Mode: *AUTO*
- CR24-B1 with user interface Mode: *AUTO-ECO-MAX*

Heat-/Chilled Ceiling-Systems

<i>Application</i>	<i>Description</i>	<i>CR24 Type</i>
IRC-CLC-0011.0	Chilled ceiling - 2-pipe-system, Room temperature controlled	CR24-B3
IRC-CLC-0015.0	Heat-/Chilled ceiling - 2-pipe-system, with Change-over function	CR24-B3



Wiring diagram CR24-B3

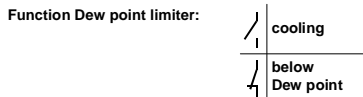
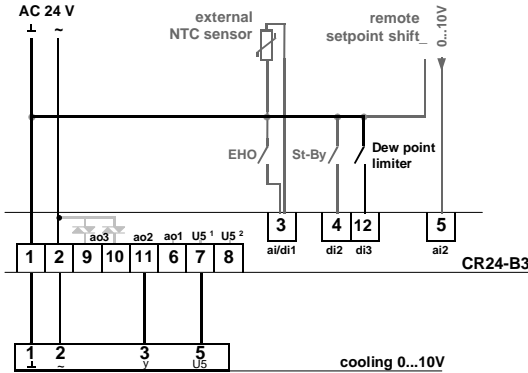

In- & Output assignment

- Inputs**
- ai/di1 EHO / ext. Sensor *
 - di2 Stand by *
 - di3 Dew point limiter
 - ai2 Remote setpoint shift *
- Outputs**
- ao2 Cooling output 0...10V

* Optional

Note

The pin numbering corresponds to the Belimo actuator connections.

Refer to the CR24 Product-Information for technical data and detailed information.

Configuration, settings CR24-B3

DIP-Switch setting:

- 1 P-Band: **normal** - wide
- 2 V_{max} Hz: **Off** - 80%
- 3 ao2: **heating** - cooling/C-O
- 4 di3: **Boost** - Dewpoint/C-O
- 5 Boost: **Temp.** - V_{max}
- 6 controller: **PI** - P

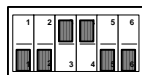

Setpoint W_H range:

15...36 °C

Description, functional diagram

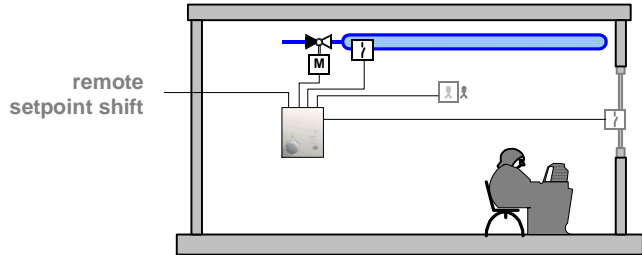

The Chilled ceiling application existing of a room temperature controller and a 0...10 V cooling valve. The dew point limiter cares for perspiration water free operation as it switches of the cooling by a 2-point signal.

Functional diagram

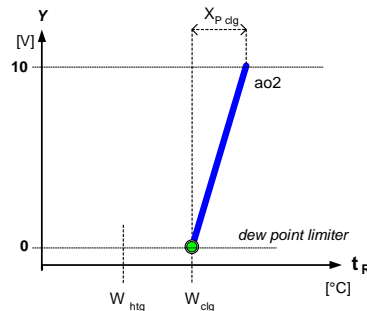

Hint

- Cooling output ao2: 0...10 V

Options

- ◆ di1 – EHO Energy hold off, e.g. window switch, ext. time switch
- ◆ di2 – Stand by, e.g. motion detector
- ◆ ai1 – external temperature sensing – exhaust duct
- ◆ ai2 – external setpoint shift, e.g. So/Wi-compensation

Operations - MMI

- CR24-A3 without user interface Mode: *AUTO*
- CR24-B3 with user interface Mode: *AUTO-ECO-MAX*



Wiring diagram CR24-B3

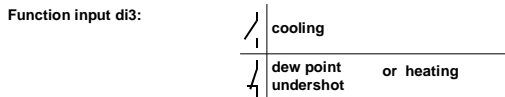
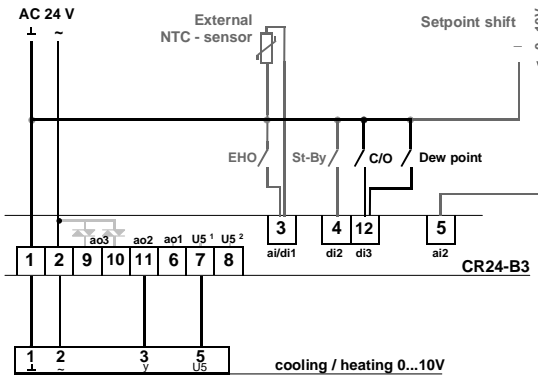

In- & Output assignment

Inputs

- ai/di1 EHO / ext. Sensor *
- di2 Stand by *
- di3 Dew point limiter / Change/over
- ai2 Remote setpoint shift *

Outputs

- ao2 Cooling/Heating 0...10V

* Optional

Note

The pin numbering corresponds to the Belimo actuator connections.

Refer to the CR24 Product-Information for technical data and detailed information.

Configuration, settings CR24-B3

DIP-Switch setting:

- 1 P-Band: **normal** - wide
- 2 V_{max} Hz: **Off** - 80%
- 3 ao2: **heating** - cooling/C-O
- 4 di3: **Boost** - Dewpoint/C-O
- 5 Boost: **Temp.** - V_{max}
- 6 controller: **PI** - P

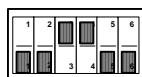

Setpoint W_H range:

15...36 °C

Description, functional diagram

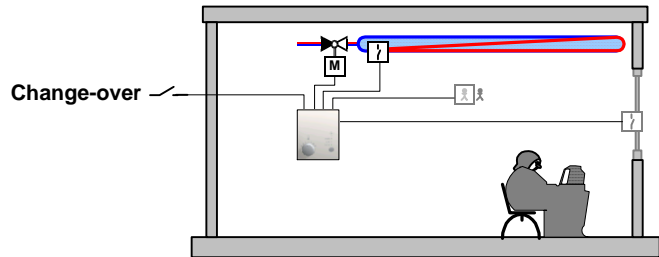

This water ceiling system can be used to cover heating and cooling demand due to the built-in Change/over function of the room temperature controller controlling the common 0...10 V valve. Change/over gets activated by an external command wired to digital input di3. The dew point limiter cares for perspiration water free operation as it switches off the cooling via a 2-point signal.

Functional diagram

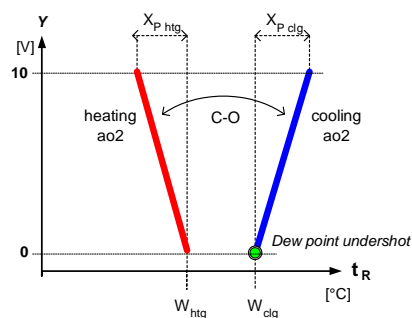

Hint

- Cooling output ao2: 0...10 V

Options

- ◆ di1 – EHO Energy hold off, e.g. window switch, ext. timeswitch
- ◆ di2 – Stand by, e.g. motion detector
- ◆ ai1 – external temperature sensing – exhaust duct
- ◆ ai2 – external setpoint shift, e.g. So/Wi-compensation

Operations - MMI

- CR24-A3 without user interface Mode: *AUTO*
- CR24-B3 with user interface Mode: *AUTO-ECO-MAX*

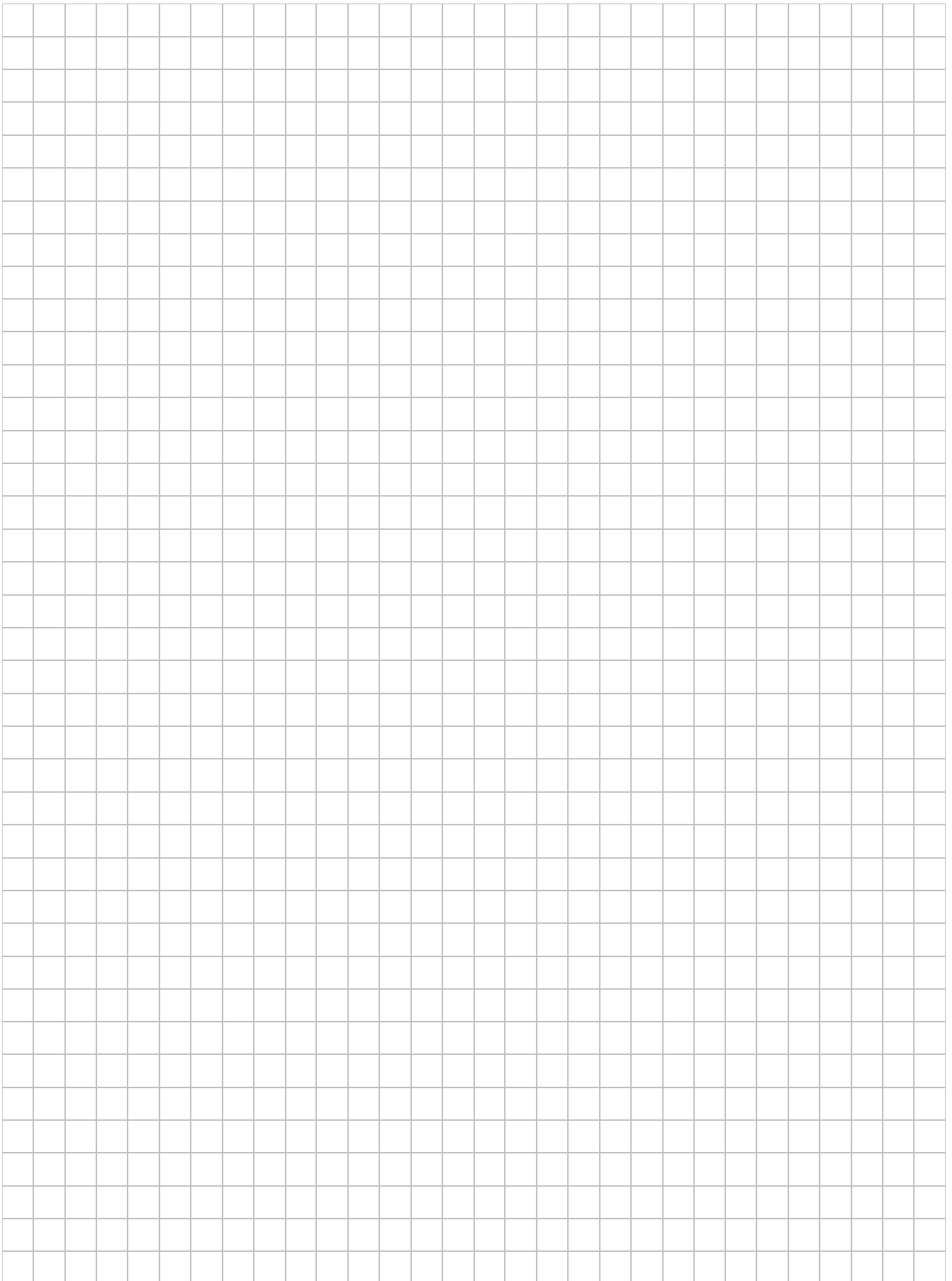

All-inclusive.



Headquarters

BELIMO Holding AG
Brunnenbachstrasse 1
CH-8340 Hinwil
Tel. +41 (0)43 843 62 11
Fax +41 (0)43 843 62 68
info@belimo.ch
www.belimo.ch

Subsidiaries, Representatives and Agencies

Argentina	Denmark	Lebanon	Rumania
Australia	Egypt	Liechtenstein	Russia
Bahrain	Estonia	Lithuania	Saudi Arabia
Belgium	Finland	Luxembourg	Singapore
Bosnia-Herzegovina	France	Malaysia	Slovakia
Brazil	Great Britain	Mexico	Slovenia
Bulgaria	Germany	Morocco	South Africa
Canada	Greece	Netherlands	Spain
Chile	Hong Kong	New Zealand	Sweden
Croatia	Hungary	Norway	Switzerland
Cyprus	Iceland	Oman	Taiwan
Czech Republic	India	Pakistan	Turkey
	Indonesia	People's Republic of China	Ukraine
	Ireland	Philippines	United Arab Emirates
	Israel	Poland	United States of America
	Italy	Portugal	
	Japan	Qatar	
	Jordan	Republic of Korea (South Korea)	
	Kuwait		
	Latvia		