

## WIRING & OPERATING THE ACTUATOR FOR MODULATING AND FAILSAFE MODULATING FUNCTION

### J3 & J3C SERIES: MODULATING & FAILSAFE MODULATING FUNCTION

#### J3/ J3C / J3CS MODULATING ELECTRIC ACTUATOR

Movement of the actuator is proportional to input signal

Power is applied continuously. Movement of valve actuator is then controlled by an internally fitted digital positioner and is proportional to changes supplied in an input control signal. This input signal is typically 0-10VDC, or 4-20mA. An output signal is supplied as standard providing closed loop control. Fails closed on loss of control signal (or see configuration options below), but stays put on loss of external power.

Configuration options:

- 1) Closes on loss of control signal
- 2) Opens on loss of control signal
- 3) Stays put on loss of control signal (Fail freeze)

#### J3/ J3C / J3CS FAILSAFE MODULATING ELECTRIC ACTUATOR (same wiring as modulating version)

Combination of failsafe & modulating above:

Uses battery failsafe system and digital positioner to provide fail to safe position function on loss of external power.

### J3 & J3C SERIES: ACTUATOR COVER & DIN PLUG IDENTIFICATION

**Models: 20, 35, 55, 85**

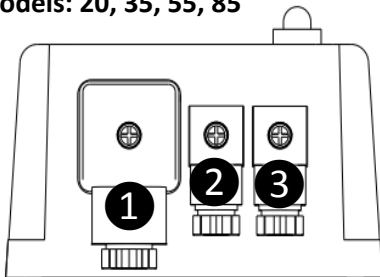

**Models: 140, 300**

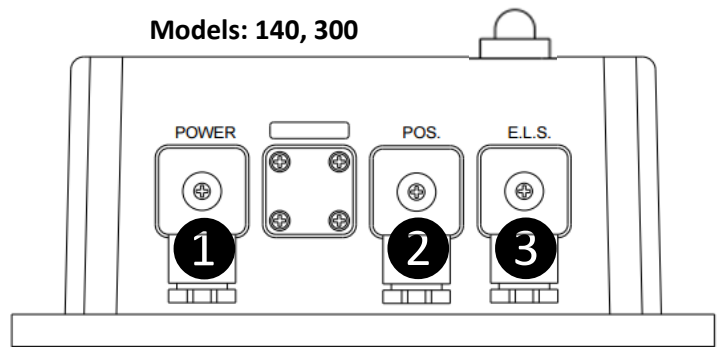

DIN PLUG IDENTIFICATION		
Models: J3-H, J3-L, J3C-H, J3C-L, J3CS		
DIN Plug No	Colour	Connection
<b>1</b>	Grey plug & base	External power
<b>2</b>	Black plug & base	Control signal (I/O)
<b>3</b>	Black plug & base	End of travel confirmation

**ELECTRICAL CONNECTIONS**

(We recommend only qualified electrical engineers make the connections)

**WIRING DIAGRAM**

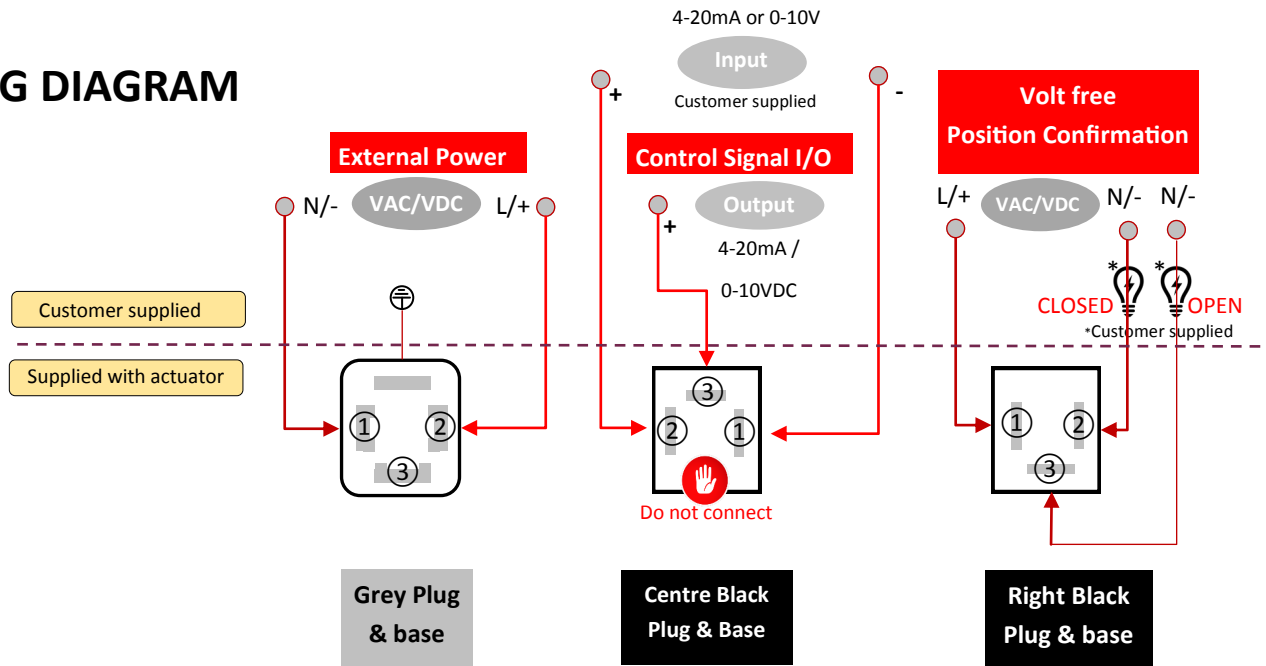

**Connecting:**

**1**

Make the **neutral (N)** connections:

- 1 x External power Din plug, pin 1
- 1 x Open confirmation Din plug, pin 3
- 1 x Closed confirmation Din plug, pin 2

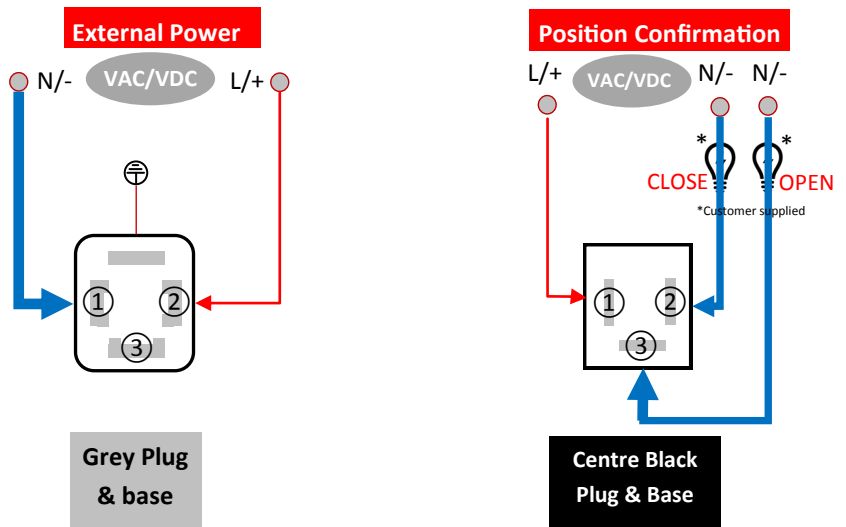

**2**

Make the **live (L) or positive (+)** connections:

In a modulating valve actuator, the power is permanently applied and NOT switched as in an on-off or failsafe actuator.

Connect a live to pin 2 of the external power Din plug, and to pin 1 of the position confirmation plug.

Apply power to pin 1 of the position confirmation plug for end of travel confirmation. This circuit is made around 5° ahead of the final closed position.

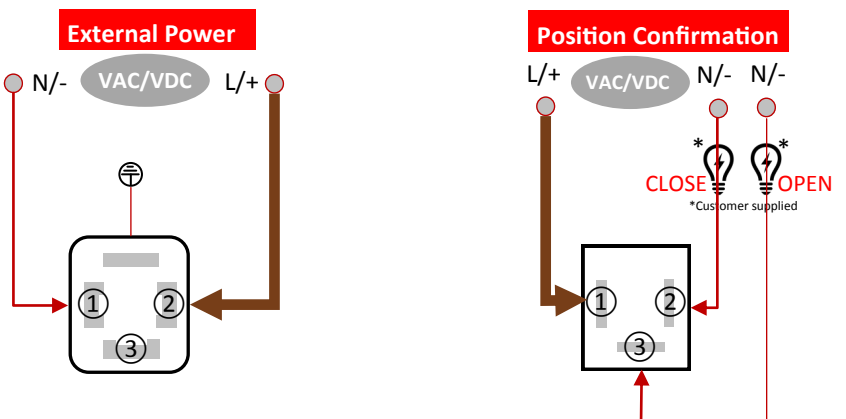

### Control Signal Connections (Centre DIN Plug)

Note: This Din plug is inverted to help prevent the possibility of the position confirmation plug being connected to the control connection, as doing so will irreparably damage the DPS positioner. Such damage is not covered by the warranty.

**3**

Make the **negative** connection from the **negative** output from your 4-20mA (or 0-10VDC) device to pin 1. Correct polarity of these control signal connections is critical so please double check.

The pin marked as earth (ground) on the control Din plug MUST NOT BE CONNECTED to anything. This pin is used for an external reset function and the positioner will not function correctly if any external connections are made to this pin.

Do not connect

#### Control Signal I/O

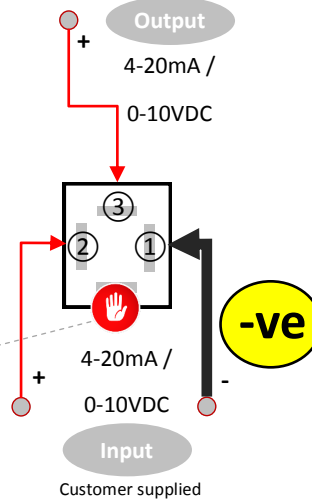

**4**

Make the **positive** connection from the **positive** output from your 4-20mA (or 0-10VDC) device to pin 2. Correct polarity of these control signal connections is critical so please double check.

The pin marked as earth (ground) on the control Din plug MUST NOT BE CONNECTED to anything. This pin is used for an external reset function and the positioner will not function correctly if any external connections are made to this pin.

Do not connect

#### Control Signal I/O

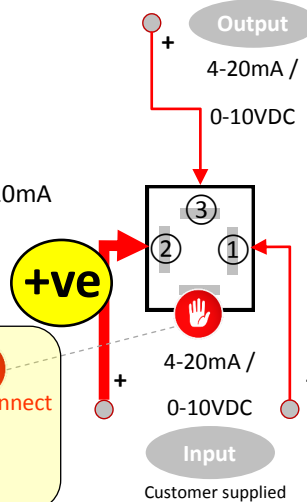

**5**

If you are using the feedback signal from the J+J actuator positioner, make the **output** connection to the **positive** input to your 4-20mA (or 0-10VDC) device to pin 3.

The pin marked as earth (ground) on the control Din plug MUST NOT BE CONNECTED to anything. This pin is used for an external reset function and the positioner will not function correctly if any external connections are made to this pin.

Do not connect

#### Control Signal I/O

