

Illustrations

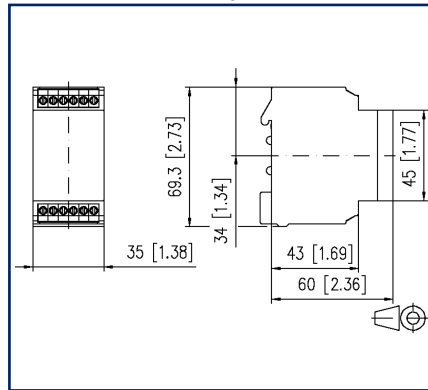

Dimensional drawing



Wiring diagram

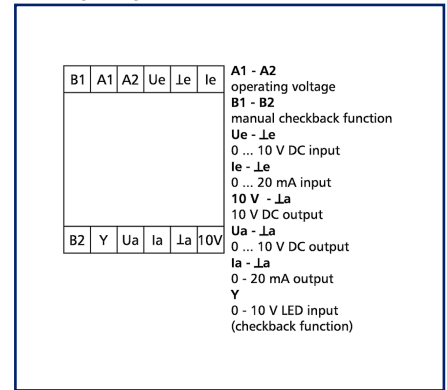

See enlarged drawings at the end of document

Product specification

The potential isolator / signal converter is used for isolating analog signals in the range from 0 to 10 V DC, and 0 to 20 mA DC or for a signal conversion from 0 to 10 V DC to 0 to 20 mA DC or 0 to 20 mA DC to 0 to 10 V DC. The input and output signals as well as the supply voltage are electrically isolated from each other. An input signal from 0 to 10 V or 0 to 20 mA can be connected to the device. Electrical isolation function: With the PT-C12, the input signal 0 to 10 V is adjusted proportionally to the output signal 0 to 10 V. The PTi-C12 adjusts the input signal from 0 to 20 mA proportional to the output signal from 0 to 20 mA. Function Signal conversion with potential separation: With a signal conversion from 0 to 10 V to 0 to 20 mA, or from 0 to 20 mA to 0 to 10 V, the output signal converted thereby can be readjusted using an integrated spindle trimmer. In addition, a manual emergency operating option with a MANUAL AUTO switch with feedback contact is also integrated. The output signal from 0 to 10 V or 0 to 20 mA can be set via the front potentiometer when the switch is in the MANUAL position. A constant output voltage of max. 10 V DC and 5 mA is available at the 10 V terminal. Input Y is used for the LED display of the output voltage Ua. The brightness of the LED depends on the level of the output signal (bridge between Ua and Y). Alternatively, an external signal at the input Y can be connected to the LED display from 0 to 10 V DC.

- Connection with screw type terminal blocks

Technical Data

Supply	
Operating voltage	24 V AC/DC -20% ... +15%
Power consumption AC (max.)	200 mA
Power consumption DC (max.)	110 mA
Power consumption AC (max.)	4.8 VA
Power consumption DC (max.)	2.64 W
Duty cycle relative	100 %
Inputs	
Voltage input	
Voltage input - input resistance	> 50 K/W
Current input	
Current input - input resistance	45 W
Outputs	
Current output current load	max. 500 Ohm
Indicator	green LED
General information	
Isolation	1000 V DC, 50 Hz, 1 min.
Housing	
Dimensions	
Dimension (W x H x D)	35 mm x 69.3 mm x 60 mm
Dimension (W x H x D)	1.378 in. x 2.728 in. x 2.362 in.
Weight	78 g
Mounting style	Standard rail TH35
Mounting position	any
Apposition	without distance
Connection type	Screw type terminal blocks
Terminal blocks	
Wire cross section solid	0.2 mm ² - 2.5 mm ² / AWG 22-12
Wire cross section multi	0.25 mm ² - 2.5 mm ² / AWG 22-12
Wire cross section with wire ferrule	0.25 mm ² - 2.5 mm ² / AWG 22-12
Screw torque (max.)	0.5 Nm
Stripping length (min.)	8 mm

Technical Data

Material	
Material - Housing	Polyamid 6.6 V0
Color	gray
Material - Terminal block	Polyamid 6.6 V0
Material - Covers	Polycarbonat
REACH	compliant
REACH - substance (SVHC)	Lead / 7439-92-1
Protection category according to IEC 60529	
Protection category - housing (acc. to IEC 60529)	IP40
Protection category - terminal blocks (acc. to IEC 60529)	IP20
Temperature range	
Operating	
Temperature - Operating °C	0 °C - 55 °C
Temperature - Operating °F	32 °F - 131 °F
Storage	
Temperature - Storage °C	-20 °C - 70 °C
Temperature - Storage °F	-4 °F - 158 °F
Power loss	
Power loss (typical)	2.6 W
Classifications	
ETIM 7.0	EC000310
ETIM 8.0	EC000310



Illustrations

Dimensional drawing

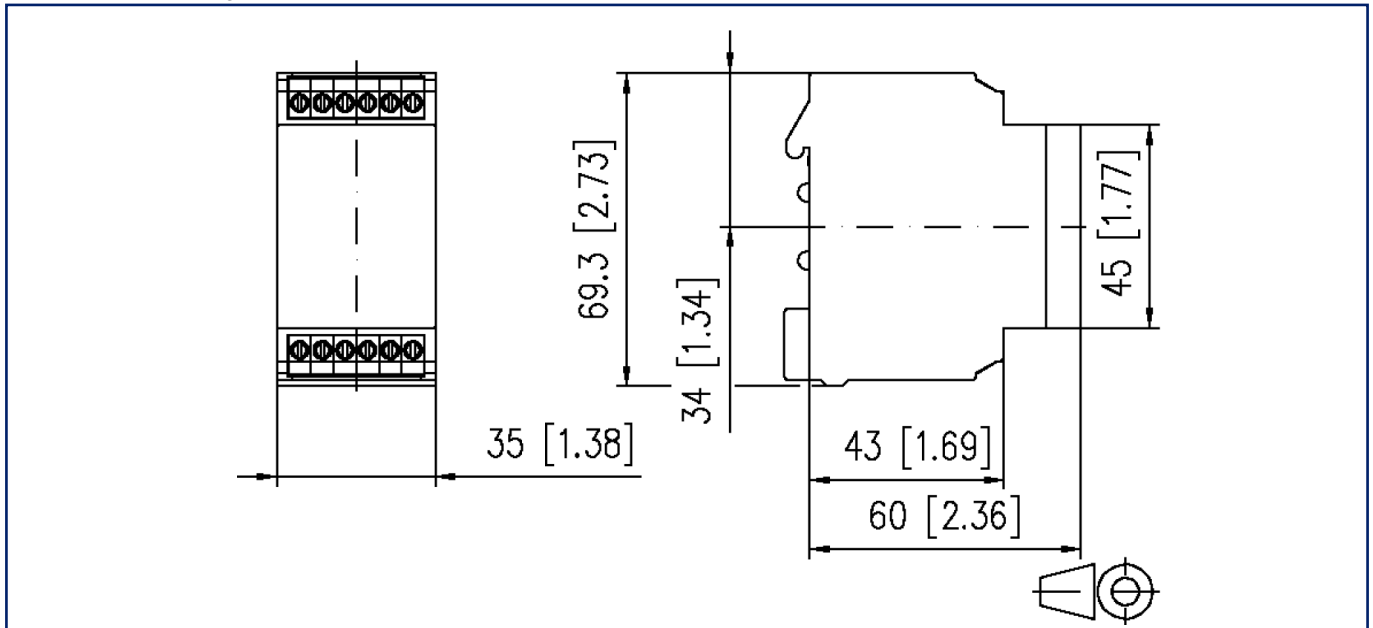

Wiring diagram

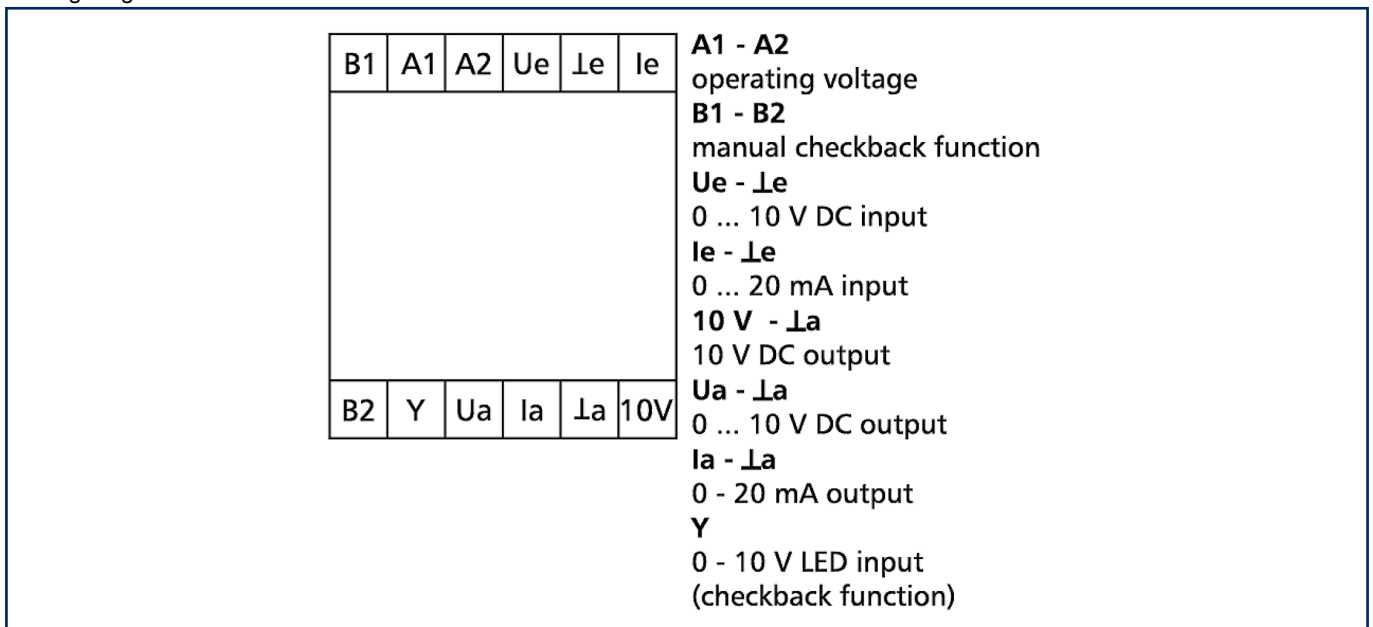

Illustrations

Circuit diagram

