



Sample image

## Datasheet

**Article number:** 70011179

**Designation:** KG100.T204/01.E

**Description:** Switch Global Disconnecter

<b>IEC 60947-3 EN 60947-3, VDE 0660 Teil 107</b>						
<b>Rated insulation voltage Ui</b>						
		Voltage (V) AC / DC				
		690 AC				
<b>Rated uninterrupted current Iu/Ith</b>						
Current (A)	Ambient temperature (°C)	Peak temperature (°C)	additional requirements			
100	50	55	Ambient temperature +50°C during 24 hours with peaks up to +55°C			
<b>Rated operational current Ie</b>						
Utilization category		Voltage (V)		Current (A)		
AC-32A		20 - 400		100		
<b>Rated operational power</b>						
Utilization category	Voltage (V)	No. of phases	No. of poles	Power (kW)		
AC-3	220 - 240	3	3	18,50		
AC-3	380 - 440	3	3	30		
AC-3	660 - 690	3	3	22		
AC-23A	220 - 240	3	3	22		
AC-23A	380 - 440	3	3	37		
AC-23A	660 - 690	3	3	30		
<b>Max. Fuse rating IEC</b>						
Fuse characteristic		No. of Fuses		Current (A)		
gG		1		100		
<b>UL60947-4-1 , UL508</b>						
<b>Nominal Voltage</b>						
		Voltage (V) AC / DC				
		600 AC				
<b>Rated insulation voltage Ui</b>						
		Voltage (V) AC / DC				
		600 AC				
<b>Rated thermal current</b>						
		Current (A)	Ambient temperature (°C)	Additional Text		
		100	0 - 40	-		
<b>Horsepower rating</b>						
Across-the-Line Motor Starting	Voltage (V)	No. of phases	No. of poles	Power (HP)	Ambient temperature [°C]	
DOL	110 - 120	1	2	5	40	
DOL	220 - 240	1	2	15	40	
DOL	277 - 277	1	2	15	40	
DOL	415 - 415	1	2	25	40	
DOL	440 - 480	1	2	30	40	
DOL	550 - 600	1	2	30	40	
DOL	110 - 120	3	3	10	40	
DOL	220 - 240	3	3	25	40	
DOL	415 - 415	3	3	40	40	
DOL	440 - 480	3	3	50	40	
DOL	550 - 600	3	3	50	40	
<b>SCCR / Max. fuse rating</b>						
<i>Conditions of acceptability</i>						
These devices are suitable for use on circuits capable of delivering not more than 10kA rms symmetrical amperes, 600V ac max. when protected by Type RK1 fuses or Circuit Breaker Type SFHA36AT0250, manufactured by General Electric.						
Suitable for use on a circuit capable of delivering not more than 65000 rms symmetrical amperes 600V max., when protected by Class J fuses, 100A max.						
<b>Temp. rating of wire</b>						
		Temperature rating (°C)	Current (A)		Text	
		75	-		-	
<b>Connecting instructions</b>						
<i>Markings</i>						
Break all lines.						
<b>General Use</b>						
AC / DC	Voltage (V)	Current (A)	No. of phases	No. of poles	No. of contacts in series	
AC	277	100	1	1	1	

General Use					
AC / DC	Voltage (V)	Current (A)	No. of phases	No. of poles	No. of contacts in series
AC	600	100	1	2	1
AC	600	100	3	3	1

**General Information**

*Text*

- The operating handle and position indicating means to be used with these manual motor controllers should be provided from the manufacturer, or the operating handle and position indicating means to be used should have been previously evaluated in combination with the manual motor controllers.

- When intended for use as a motor disconnecter the device shall be provided with a method of being locked in the OFF-position.

**CSA**

Nominal Voltage	
Voltage (V)	AC / DC
600	AC

Rated insulation voltage Ui	
Voltage (V)	AC / DC
600	AC

Rated thermal current		
Current (A)	Ambient temperature (°C)	Additional Text
100	0 - 40	-

Horsepower rating					
Across-the-Line Motor Starting	Voltage (V)	No. of phases	No. of poles	Power (HP)	Ambient temperature [°C]
DOL	110 - 120	1	2	5	40
DOL	220 - 240	1	2	15	40
DOL	277 - 277	1	2	15	40
DOL	415 - 415	1	2	25	40
DOL	440 - 480	1	2	30	40
DOL	550 - 600	1	2	30	40
DOL	110 - 120	3	3	10	40
DOL	220 - 240	3	3	25	40
DOL	415 - 415	3	3	40	40
DOL	440 - 480	3	3	50	40
DOL	550 - 600	3	3	50	40

Temp. rating of wire	
Temperature rating (°C)	Current (A) Text
75	--

General Use					
AC / DC	Voltage (V)	Current (A)	No. of phases	No. of poles	No. of contacts in series
AC	277	100	1	1	1
AC	600	100	1	2	1
AC	600	100	3	3	1





**GENERAL TECHNICAL INFORMATION**

Size of conductor				
composition of conductor	Min. / Max. value	No. of conductor per terminal	Cross section (mm <sup>2</sup> ) or (AWG/kcmil)	Material of the wire
solid wire	Min.	1	2.5mm <sup>2</sup>	Copper
flexible wire	Min.	1	4mm <sup>2</sup>	Copper
flexible wire	Max.	1	35mm <sup>2</sup>	Copper
flexible wire	Max.	1	AWG 2	Copper
Single-core or stranded wire	Max.	1	AWG 1/0	Copper
Single-core or stranded wire	Max.	1	50mm <sup>2</sup>	Copper
flexible wire with sleeve	Max.	1	35mm <sup>2</sup>	Copper
flexible wire with ferrule according to DIN 46228	Min.	1	2.5mm <sup>2</sup>	Copper

Stripping length	
Length (mm)	--
14	

Recommended screw driver	
Type of screw driver	Value
Cross Screwdriver	PH2
Slot screwdriver according to DIN 5264	1,2x6,5

Tightening torque of screws		
	tightening torque (Nm)	tightening torque (lb-in)
	3	27

Approbations	
Specification	Marking
EAC	
CE marking	
UK Directives	
CSA C.22.2 No.14	
GB/T14048.3	

## General Information

### Text

- Do not lubricate or treat contacts.
- Switches may only be mounted, connected and set into operation by qualified persons according to the accepted rules of technology.
- Use copper wire only. Do not coat the wire end with tin.
- Terminals with factory fitted jumper links are tightened during production. Take care during installation to ensure factory fitted links are not lost by undoing both sides of linked terminals. After wiring, all terminal screws must be tightened to recommended torque specifications.

### Waste Electrical & Electronic Equipment (WEEE)

#### Picture name

#### Description



Do not throw in the trash as care must be taken to ensure environmentally sound disposal and recycling. Please either use an environmentally friendly waste disposal company; return to the supplier for disposal, or return direct to the manufacturer, Kraus & Naimer. You can find local Kraus & Naimer offices at [www.krausnaimer.com](http://www.krausnaimer.com)

### Proposition 65

#### Picture name

#### Description



WARNING: This product can expose you to chemicals including nickel and lead, which is known to the State of California to cause cancer. For more information go to [www.P65Warnings.ca.gov](http://www.P65Warnings.ca.gov).

Classification Contact: Rigid contact bridge

Classification Contact Mat: Silver

Classification Terminal: Screw terminal

## Mounting-E

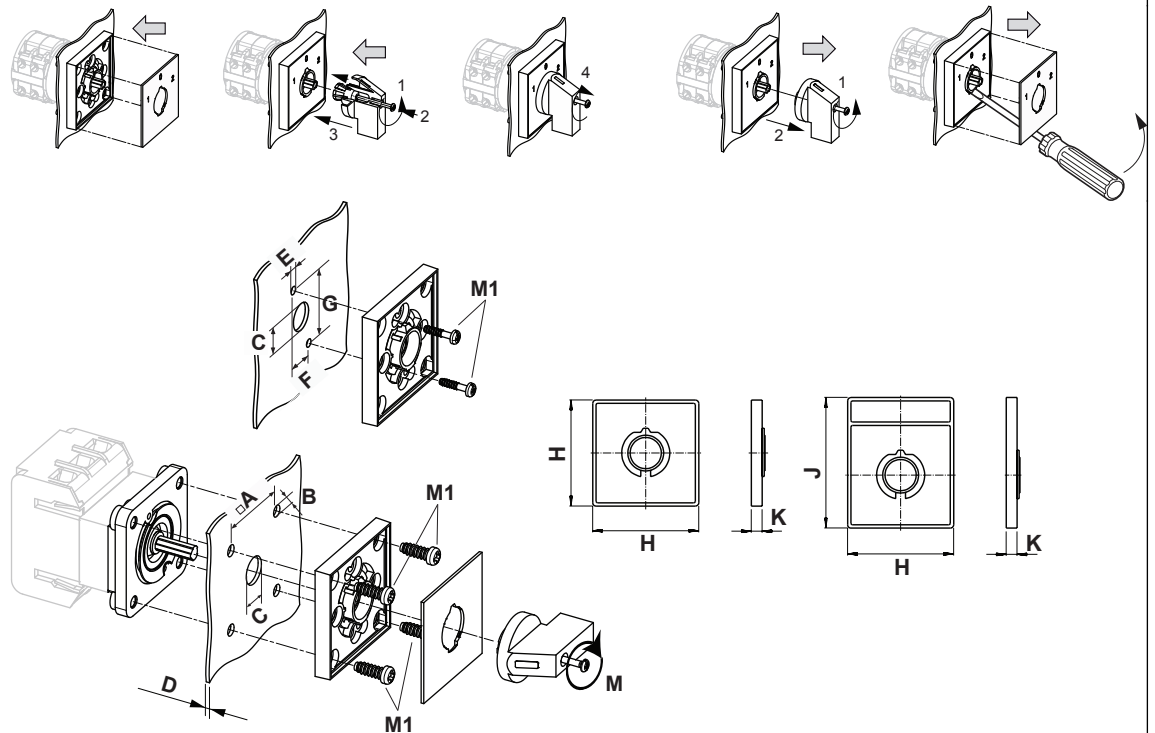

IP - Code front side		IP66, IP67
Stages		1,00 - 12,00
A	□	48,00 mm
B	∅	5,00 mm
C	∅	10,00 - 15,00 mm
D	H	<= 4,00 mm
E	∅	4,50 mm
F	H	14,00 mm
G	H	37,00 mm
H	H	64,00 mm
J	H	78,00 mm
K	H	7,40 mm
M	⌘	0,70 Nm
M1	⌘	0,90 Nm

## Wiring diagram

KG100.T304.E





**Face plate**

S1.F456/C10.V11H

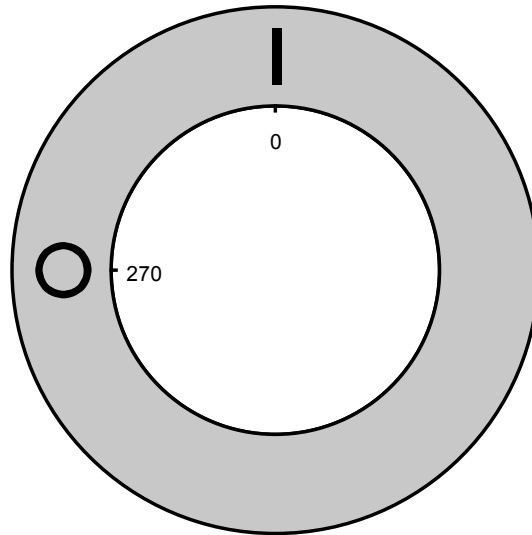



Sample image

## PADLOCK DEVICE

with F-handle ring

**Designation:** S1.V840G/D61/A2

**Colour of F-handle ring:** "D" red

**Colour of face ring:** "6" yellow

**Locking position:** "1" at 270° (1x90°)

**Type of mounting:** "A" for type of mounting E

**Type of mounting:** "A" for type of mounting GK (Rose)

**Switch type:** "2" for KA-, KG- and KH(R)-switches

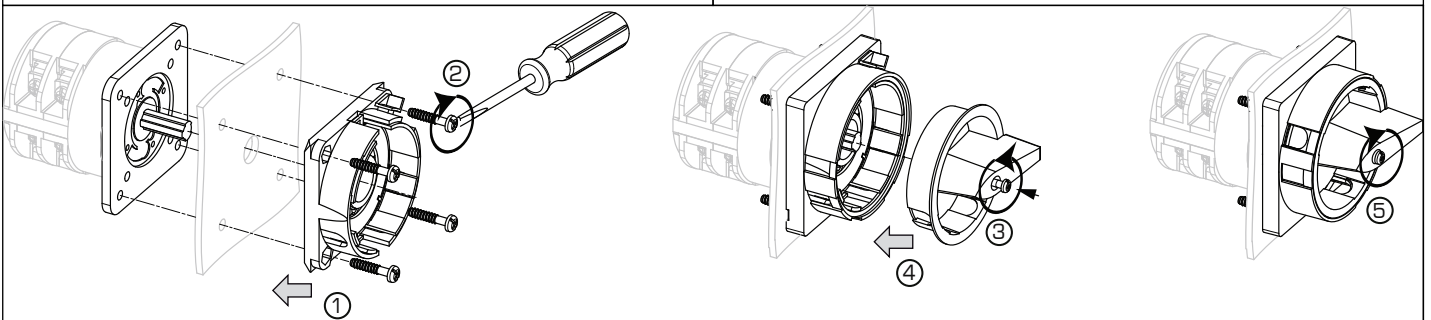
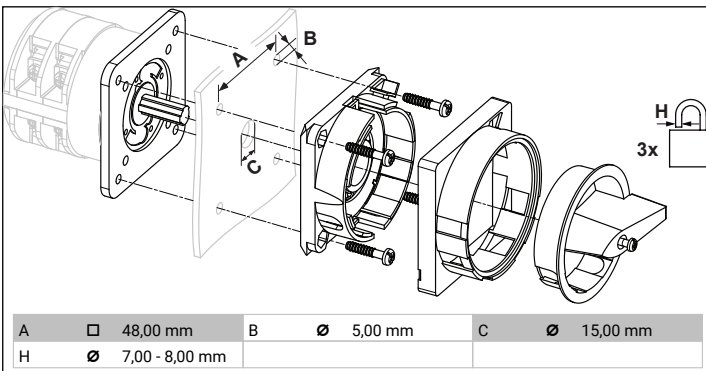

### MOUNTING

1 + 2 The padlock device has to be mounted by four cylinder head screws from the front.

3 Loosen the screw and

4 Push it into the handle onto the shaft

5 Fasten the screw.

