



## Main

Range of product	Harmony XAC
Product or component type	Pendant control station
Device short name	XACA pistol grip

## Complementary

Control station type	Double insulated
Enclosure material	Polypropylene
Control type	Intuitive
Electrical circuit type	Control circuit
Enclosure type	Complete ready for use
Control station application	Control of single speed hoist motor
Control station composition	2 push-buttons + 1 emergency stop
Control button type	First push-button 1 NO raise, slow First push-button 1 NO raise, slow Second push-button 1 NO lower, slow Emergency stop push-button Ø 30 mm 1 NC trigger action
Product compatibility	ZB2BE101 for each direction ZB2BE102 for emergency stop
Mechanical interlocking	With mechanical interlocking
Control station colour	Yellow
Connections - terminals	Screw clamp terminals 1 x 2.5 mm <sup>2</sup> with or without cable end Screw clamp terminals 2 x 1.5 mm <sup>2</sup> with or without cable end
Standards	EN/IEC 60204-32 EN/IEC 60947-5-1 EN/IEC 60947-5-5 EN/ISO 13850: 2006 UL 508 CSA C22.2 No 14
Product certifications	CSA UL
Protective treatment	TH
Ambient air temperature for operation	-25...70 °C
Ambient air temperature for storage	-40...70 °C
Vibration resistance	15 gn 10...500 Hz IEC 60068-2-6
Shock resistance	100 gn IEC 60068-2-27
Overvoltage category	Class II IEC 61140
IP degree of protection	IP65 IEC 60529
IK degree of protection	IK08 EN 50102
Mechanical durability	1000000 cycles
Cable entry	Rubber sleeve with stepped entry 7...15 mm
Contact code designation	A600 AC-15 240 V 3 A IEC 60947-5-1 appendix A A600 AC-15 600 V 1.2 A IEC 60947-5-1 appendix A Q600 DC-13 250 V 0.27 A IEC 60947-5-1 appendix A Q600 DC-13 600 V 0.1 A IEC 60947-5-1 appendix A

[Ithe] conventional enclosed thermal current	10 A
[Ui] rated insulation voltage	600 V 3 IEC 60947-1
[Uimp] rated impulse withstand voltage	6 kV IEC 60947-1
Contacts operation	Slow-break
Resistance across terminals	<= 25 MOhm
Operating force	13...15 N
Short circuit protection	10 A fuse protection cartridge gG
Rated operational power in W	40 W DC-13 1000000 cycles 60 cyc/mn 120 V 0.5 inductive IEC 60947-5-1 appendix C 48 W DC-13 1000000 cycles 60 cyc/mn 48 V 0.5 inductive IEC 60947-5-1 appendix C 65 W DC-13 1000000 cycles 60 cyc/mn 24 V 0.5 inductive IEC 60947-5-1 appendix C
Terminals description ISO n°1	(13-14)NO
Terminals description ISO n°2	(11-12)NC
Terminal identifier	(11-12)NC (13-14)NO
Product weight	0.31 kg

## Environment

### Offer Sustainability

Sustainable offer status	Green Premium product
RoHS (date code: YYWW)	Compliant - since 0943 - Schneider Electric declaration of conformity
REACH	Reference not containing SVHC above the threshold
Product environmental profile	Available
Product end of life instructions	Need no specific recycling operations

### Contractual warranty

Warranty period	18 months
-----------------	-----------

## Dimensions

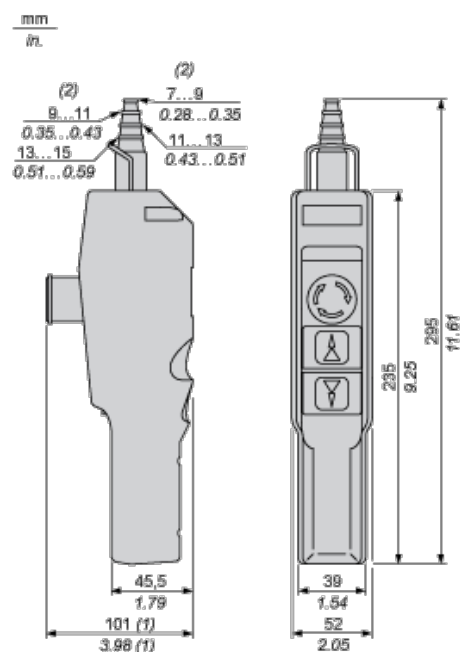

- (1) With trigger action latching Ø 30 mm / 1.18 in. Emergency stop.  
(2) Internal Ø

## Control of Single-Speed Reversing Motor

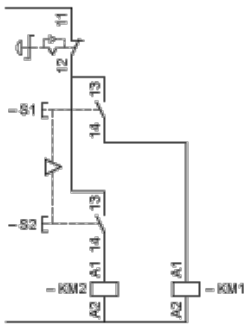

## Rated Operational Power

### AC Supply 50/60 Hz Inductive Circuit

Operating rate: 3600 operating cycles/hour. Load factor: 0.5.

Millions of operating cycles, AC-15 utilization category

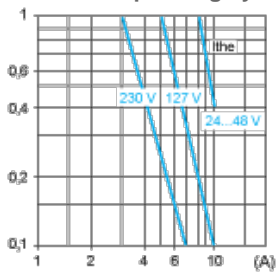

I<sub>the</sub> Thermal current

(A) Current

### DC Supply

Operating rate: 3600 operating cycles/hour. Load factor: 0.5.

Power broken in W for 1 million operating cycles, DC-13 utilization category

Voltage	V	24	48	120
Inductive circuit	W	65	48	40