







Electromotive 2 way globe control valve

- Highly precise, dynamic closed-loop control
- Several K_v values per port size due to removable valve seats
- Weather, impact and vibration resistant design
- Easy to clean thanks to the hygienically designed surface
- Position controller and process controller available

Product variants described in the data sheet may differ from the product presentation and description.

Can be combined with

	Type 3320 Electromotive 2/2 way angle seat valve (ON/OFF)	▶
	Type 3321 Electromotive 2/2 way globe valve (ON/OFF)	▶
	Type 8098 FLOWave SAW flow-meter	▶
	Type ME43 Fieldbus gateway	▶

Type description

The innovative process controller Bürkert valve Type 3361 is the solution when it comes to demanding control tasks and operating conditions.

The electromotive actuator with ball screw positions the control cone with highest precision. A unique feature is its high positioning speed up to 6 mm/s, that reacts almost delay-free to process signals, and can be varied according to customer demands. Pressure fluctuations or surges in the medium are not transferred to the valve position. Each flow optimised valve body can be equipped with up to 5 different valve seats for a precise adaptation according to customer needs. If necessary, the safety position can be approached by an optional energy storage in case of power failure.

Actuator and valve are adapted perfectly to each other with closed design and robust surface. This ensures the hygienic requirements of fast and residue-free cleaning.

Harsh environmental conditions are no problem for the Type 3361 because of the protection class IP65/IP67 and its high impact and vibration resistance. Unrivalled service life and tightness is guaranteed by the proven self adjusting packing gland with exchangeable V-seals.

The fieldbus suitable Type 3361 provides many helpful functions for process monitoring, valve diagnostics and predictive maintenance and therefore offers the decisive advantage of a modern process automation.

Table of contents

1. General technical data	3
2. Approvals	5
3. Materials	6
3.1. Chemical Resistance Chart – Bürkert resistApp.....	6
3.2. Material specifications.....	6
4. Dimensions	8
4.1. Actuator	8
AG2	8
AG3	10
4.2. Body with flange connection	12
4.3. Body with thread connection.....	13
4.4. Body with weld connection	14
4.5. Body with clamp connection	15
5. Performance specifications	16
5.1. Fluidic data	16
Flow characteristics	16
Overview of flow characteristics with flow below seat	17
5.2. Operating limits.....	19
Operating limits for medium temperature and operating pressure.....	19
Operating limits for ambient and medium temperature	20
Operating limits for seat seal	21
Operating limits for optional versions	21
5.3. Electrical control and interfaces	22
Interface diagram.....	22
6. Product design and assembly	23
6.1. Product features	23
6.2. Product assembly	25
AG2	25
AG3	26
7. Ordering information	27
7.1. Bürkert eShop – Easy ordering and quick delivery.....	27
7.2. Bürkert product filter.....	27
7.3. Ordering chart accessories.....	27
Standard accessories	27
Accessories cable.....	27
Bürkert accessories	28
7.4. Bürkert product enquiry form	28

1. General technical data

Note:

- **AG2:** Actuator size 2 with a nominal force of 1300 or 2500 N for seat size 3...50
- **AG3:** Actuator size 3 with a nominal force of 7700 or 10000 N for seat size 40...100

Product properties	
Dimensions	Detailed information can be found in chapter “4. Dimensions” on page 8.
Material	Detailed information can be found in chapter “3. Materials” on page 6.
Design	Globe control valve
Nominal diameter	DN 10...100, NPS ¾...4
Safety setting in case of power failure	With SAFEPOS energy-pack: open, closed or freely programmable Without SAFEPOS energy-pack: blocked in last position
Flow direction	Against closing direction (below seat)
Controller version	Position controller or process controller
Weight	Actuator depending on version up to: AG2: 5.5 kg AG3: 16 kg (Total weight including valve body depending on port connection)
Performance data	
Operating pressure	0...25 bar(g) (see “5.1. Fluidic data” on page 16) Vacuum version up to -0.9 bar(g) (optional)
Nominal pressure	PN 25 (DIN EN 1333), Class 150 (DIN EN 1759)
K_{vs} value	0.1...140 m ³ /h (see “5.1. Fluidic data” on page 16)
Flow characteristic	Linear or equal percentage (see “5.1. Fluidic data” on page 16)
Seat leakage (DIN EN 60534 - 4)	Class III, IV and VI (see “5.1. Fluidic data” on page 16)
Closing time ¹⁾	AG2: 3.3...6.6 s AG3: 8.7...12.0 s (Depending on travel speed, stroke and operating conditions)
Theoretical rangeability	Up to 50:1 (see “5.1. Fluidic data” on page 16)
Travel speed ¹⁾	6 mm/s (for AG2 actuator force 1300 N) 4 mm/s (for AG2 actuator force 2500 N) 3 mm/s (for AG3 actuator force 7700 N and 10000 N) (Depending on operating conditions)
Dead band of the position control	±0.1 %
Electrical data	
Operating voltage	24 V DC ± 10 % (max. residual ripple 10 %)
Operating current ¹⁾	AG2: Max. 3 A (at max. load and including 1 A charging current of the optional SAFEPOS energy-pack). At minimum operating temperature additionally 2 A AG3: Max. 5 A (at max. load and including charging current of the optional SAFEPOS energy-pack). At minimum operating temperature additionally 6 A
Protection class (DIN EN 61140)	3
Duty cycle	100 %
Standby consumption ¹⁾	2...5 W
Communication and control	
Standard signal (analogue)	Setpoint: 0/4...20 mA, 0...5/10 V and digital input (further inputs and outputs optional, see “5.3. Electrical control and interfaces” on page 22)
Fieldbus (digital)	Bürkert system bus (bùS) CANopen (optional) EtherNet/IP, PROFINET, Modbus/TCP (optional via integrated gateway)
Media data	
Process medium	Steam, neutral gases, water, alcohols, oils, fuels, hydraulic fluids, salt solutions, lyes, organic solvents, oxygen (optional)
Medium temperature	-40...+230 °C (see “5.2. Operating limits” on page 19)
Viscosity	Up to 600 mm ² /s

Process/Port connection & communication**Port connection²⁾**

Welded connection	DIN EN ISO 1127/ISO 4200/DIN 11866 B DIN 11850 2/DIN 11866 A ASME BPE/DIN 11866 C SMS 3008
Clamp connection	DIN 32676 B (pipe ISO 4200) DIN 32676 A (pipe DIN 11850 2) ASME BPE
Threaded connection	G (EN ISO 228-1) Rc (EN ISO 228-1, ISO 7/1 /DIN EN 10226-2) NPT (ASME B 1.20.1)
Flange connection	DIN EN 1092-1 ANSI B 16.5 JIS 10K

Electrical connection

Actuator	Terminal strip with cable gland 3 x M20 (only AG2), or 2 M12 circular plugs, 5 pin and 8 pin, 1 M12 circular socket, 5 pin (only for process controller function)
Fieldbus gateway	2 M12 circular sockets, 4 pin (only for industrial ethernets)

Approvals and certificates

Conformity	Food EGV 1935/2004 FDA (Optional)
Approval	Explosion protection ATEX/IECEx (Optional) (see “2. Approvals” on page 5) cULus (only AG2) (Optional) (see “2. Approvals” on page 5)
Ignition protection class	II 3G Ex ec IIC T4 Gc II 3D Ex tc IIIC T135 °C Dc
Detergent resistance	According to Ecolab test method: R&D/P3-E No. 40-1









Environment and installation

Ambient temperature	-25...+65 °C (only without additional modules) (Derating see “Operating limits for ambient and medium temperature” on page 20)
Degree of protection	IP65/IP67 (DIN EN 60529), NEMA 4X (only AG2)
Installation position	Any, preferably actuator face up

1.) All values refer to a supply voltage of 24 V at 25 °C.

2.) Others on request

2. Approvals

Approvals/ Conformity/ Certificate	Description
	Food produce contact Materials in contact with medium conform to EC regulation 1935/2004 Materials in contact with medium conform to FDA (optional)
	Drinking water Suitable for use with drinking water according to KTW, W270 (optional)
	Oxygen Suitable for use with gaseous oxygen (optional)
 	Explosion proof As category 3 device suitable for zone 2/22 (optional) ATEX <ul style="list-style-type: none"> • II 3G Ex ec IIC T4 Gc • II 3D Ex tc IIIC T135 °C Dc IECEX <ul style="list-style-type: none"> • Ex ec IIC T4 Gc • Ex tc IIIC T135 °C Dc
	Safety requirements UL-listed cULus Cert. No. 238179 (optional) (only AG2)
	Detergent resistance Material compatibility tested with common Ecolab products and certified according to Ecolab test method: R&D/P3-E No. 40-1
Standards	Description
	Field device for integration into the EDIP platform via Bürkert system bus (büS)

3. Materials

3.1. Chemical Resistance Chart – Bürkert resistApp

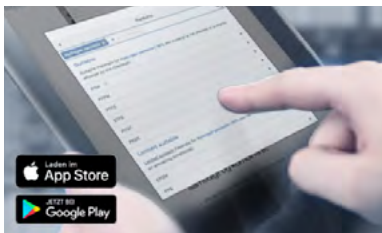

Bürkert resistApp – Chemical Resistance Chart

You want to ensure the reliability and durability of the materials in your individual application case? Verify your combination of media and materials on our website or in our resistApp.

[Start Chemical Resistance Check](#)

3.2. Material specifications

Note:

The Type 3361 globe control valve is supplied with various port connections (flange, thread, weld end and clamp connections). These connections are not shown. They are the same material as the valve body.

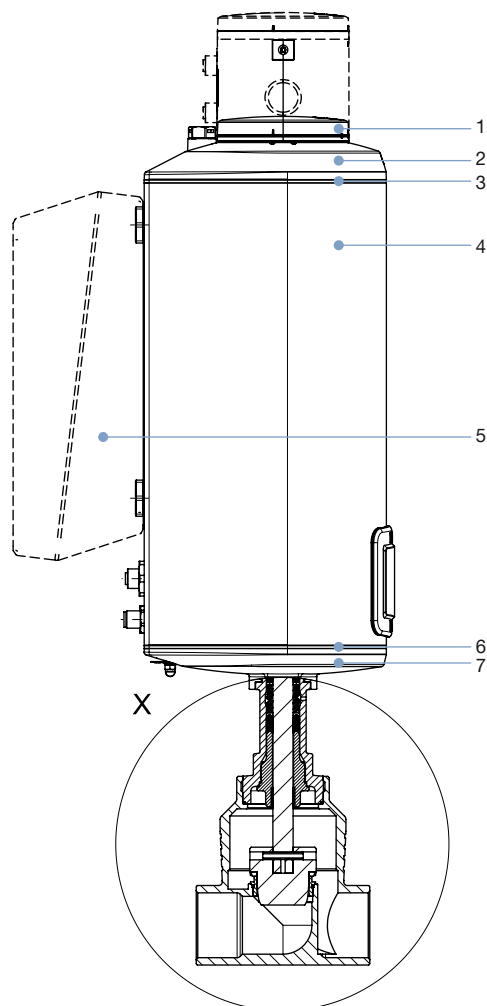

AG2

No.	Component	Material
1	Display housing/Blind cover /Gateway housing	PPS (Standard), Stainless steel 1.4301 (for ATEX/IECEX)
2	Actuator cover	PPS
3	Seal	EPDM
4	Actuator housing	Aluminium powder coated
6	Seal	EPDM
7	Actuator base	PPS

AG3

No.	Component	Material
1	Display housing/Blind cover /Gateway housing	PPS (Standard), Stainless steel 1.4301 (for ATEX/IECEX)
2	Actuator cover	PC
3	Seal	EPDM
4	Actuator housing	Aluminium powder coated
5	SAFEPOS energy pack	PC
6	Seal	EPDM
7	Actuator base	Stainless steel 1.4308

DTS 1000273772 EN Version: S Status: RL (released | freigegeben | validé) printed: 28.02.2023

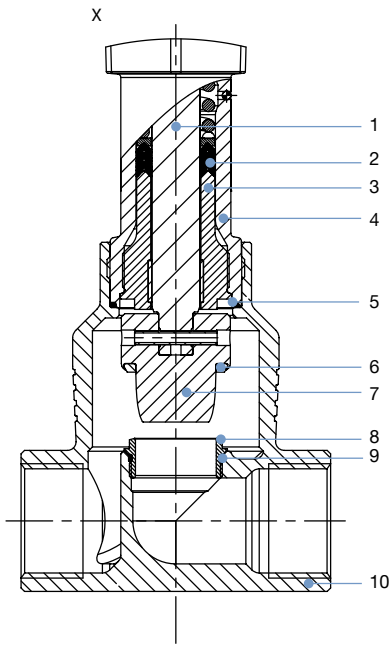

No.	Component	Material
1	Spindle	Stainless steel 1.4401 (316)/1.4404 (316L)
2	Spindle seal	PTFE V-seals (filled) with spring compensation
3	Spindle guidance	Stainless steel 1.4404 (316L)
4	Packing gland tube	Stainless steel 1.4401 (316)
5	Seal valve body	Graphite or PTFE
6	Seat seal	Stainless steel 1.4571 (optionally hardened) PTFE or PEEK seal washer
7	Control cone	Stainless steel 1.4571 (optionally hardened)
8	Valve seat	Stainless steel 1.4571 (optionally hardened)
9	O-Ring valve seat	EPDM or PTFE
10	Valve body	Stainless steel CF3M

4. Dimensions

4.1. Actuator

AG2

Note:

Dimensions in mm, unless otherwise stated

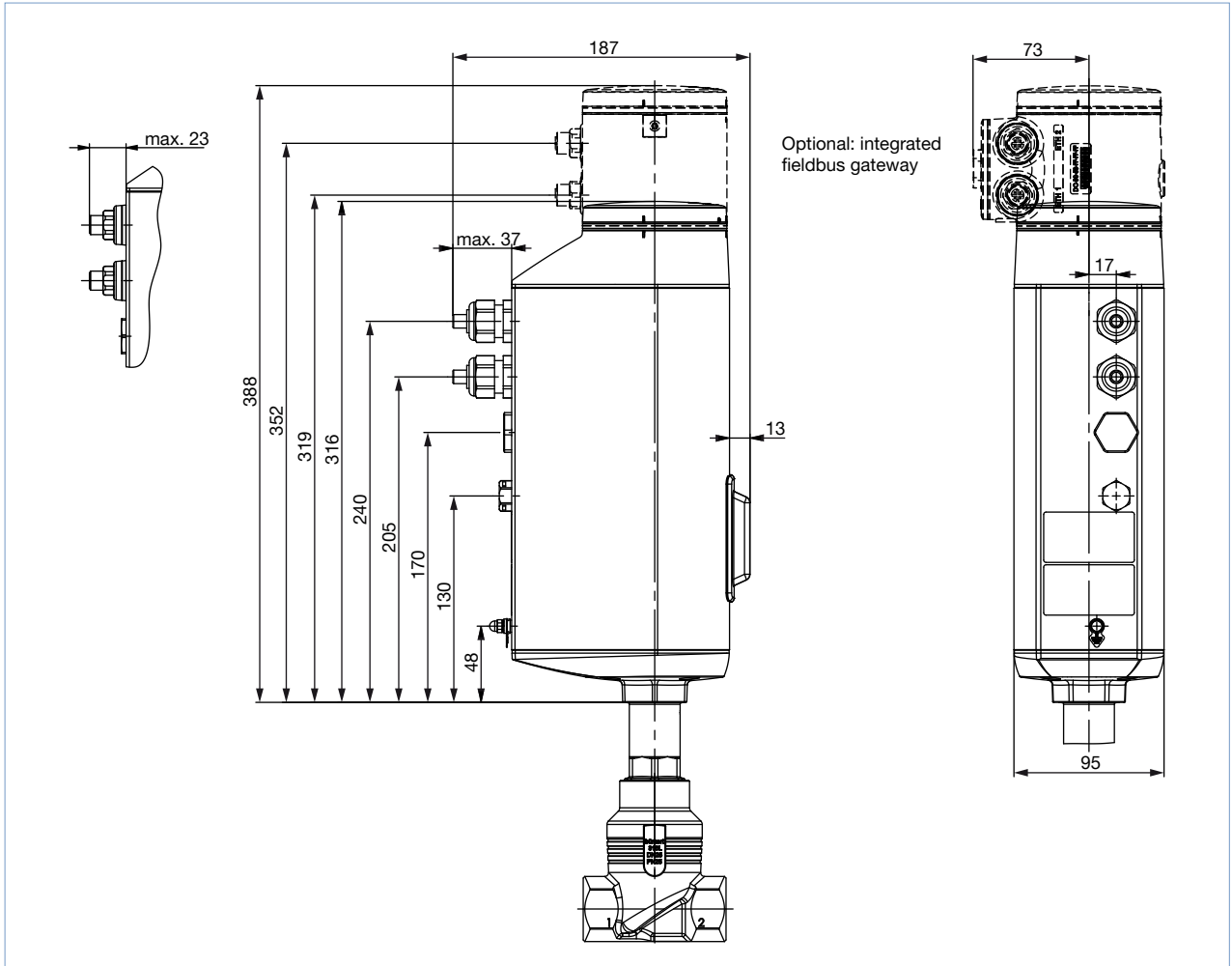

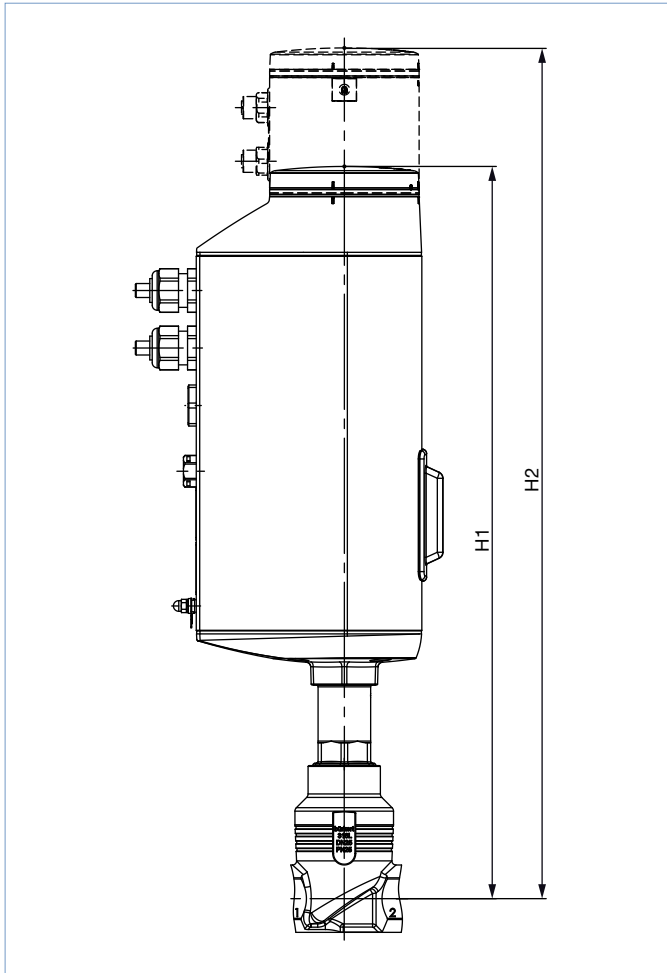

Nominal diameter (Pipe)		Height ^{1.)}	
DN	NPS	H1 Standard variant	H2 ^{2.)} Fieldbus variant (KOMM ≠ G, N, L)
10	3/8	417	489
15	1/2	417	489
20	3/4	423	495
25	1	446	518
32	1 1/4	474	546
40	1 1/2	479	551
50	2	485	557

1.) Dimensions without tight-closing function: in closed position the actuator additionally lifts by approx. 2 mm

2.) Optional: integrated fieldbus gateway

AG3

Note:

Dimensions in mm, unless otherwise stated

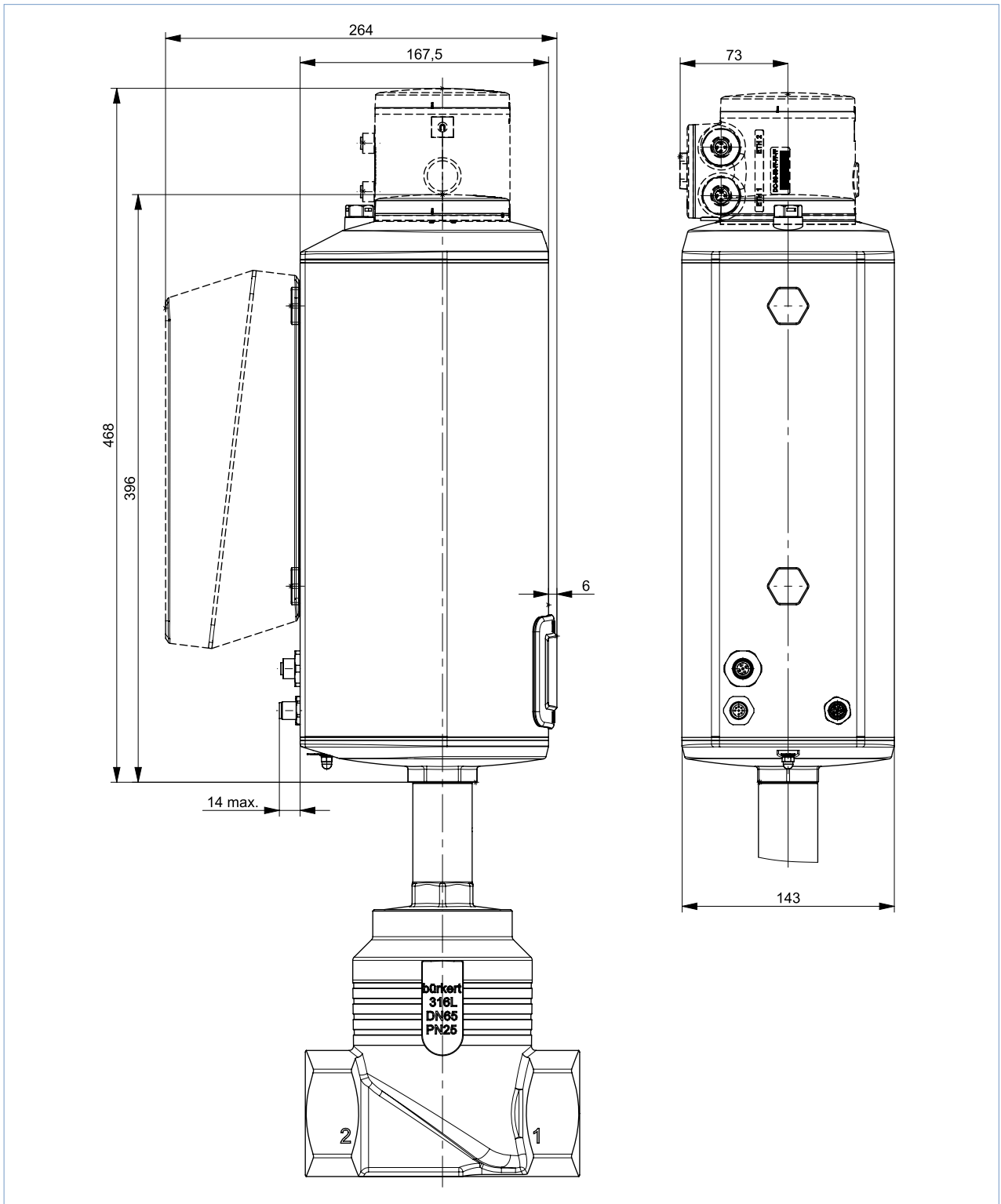

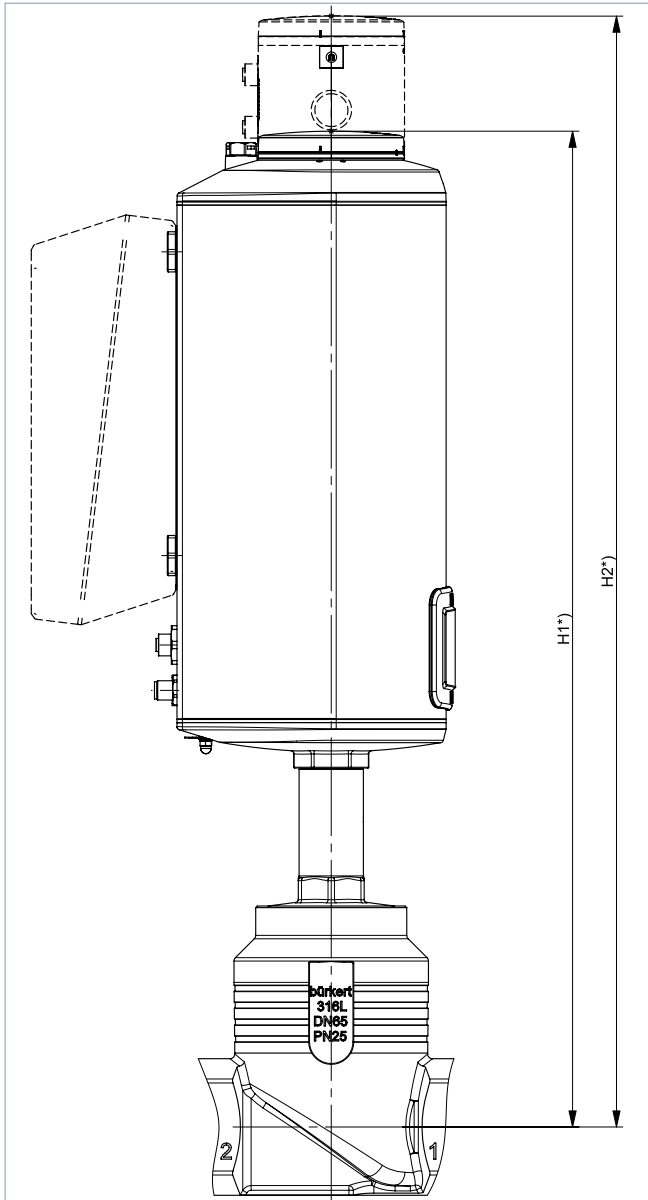

Nominal diameter (Pipe)		Height ^{1.)}	
DN	NPS	H1 Standard Version	H2 ^{2.)} Fieldbus Version (KOMM ≠ G, N, L)
40	1½	560	632
50	2	566	638
65	2½	620	692
80	3	628	700
100	4	638	710

1.) Dimensions without tight-closing function: in closed position the actuator additionally lifts by approx. 2 mm

2.) Optional: integrated fieldbus gateway

4.2. Body with flange connection

Note:

Dimensions in mm, unless otherwise stated

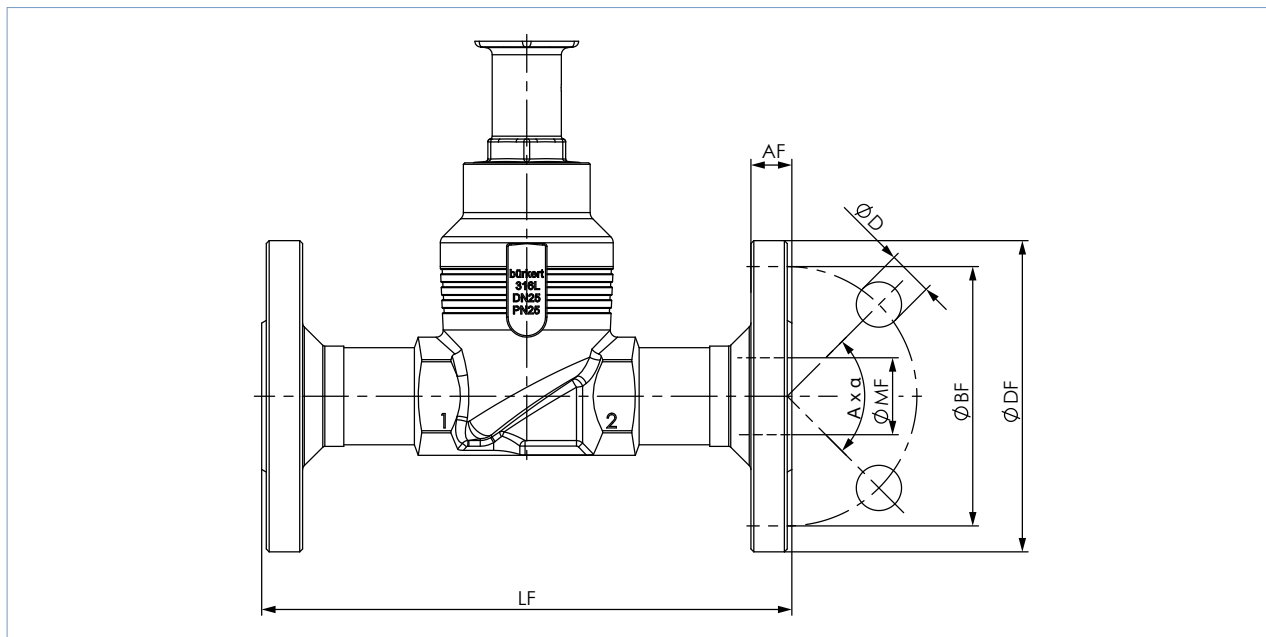

Nominal diameter (Pipe)	DIN EN 1092 PN 25 FTF 1 acc. to DIN EN 558-1							JIS 10K FTF 10 acc. to DIN EN 558-2							
	DN	ØDF	LF	ØBF	AF	ØD	A x α	ØMF	ØDF	LF	ØBF	AF	ØD	A x α	ØMF
10	90	130	60	16	14	4 x 90°	13.6	-	-	-	-	-	-	-	-
15	95	130	65	16	14	4 x 90°	18.1	95	108	70	12	15	4 x 90°	18.1	
20	105	150	75	18	14	4 x 90°	23.7	100	117	75	14	15	4 x 90°	23.7	
25	115	160	85	18	14	4 x 90°	29.7	125	127	90	14	19	4 x 90°	29.7	
32	140	180	100	18	18	4 x 90°	38.4	135	140	100	16	19	4 x 90°	38.4	
40	150	200	110	18	18	4 x 90°	44.3	140	165	105	16	19	4 x 90°	44.3	
50	165	230	125	20	18	4 x 90°	56.3	155	203	120	16	19	4 x 90°	56.3	
65	185	290	145	22	18	8 x 45°	66.0	175	216	140	18	19	4 x 90°	71.5	
80	200	310	160	24	18	8 x 45°	81.0	185	241	150	18	19	8 x 45°	84.3	
100	235	350	190	24	22	8 x 45°	100.0	292	292	175	18	19	8 x 45°	109.1	

Nominal diameter (Pipe)	ANSI B 16.5 Class 150 FTF 37 acc. to DIN EN 558-2						
	NPS	ØDF	LF	ØBF	AF	ØD	A x α
½	89	184	60.5	11.2	15.7	4 x 90°	15.7
¾	99	184	69.9	12.7	15.7	4 x 90°	20.8
1	108	184	79.2	14.2	15.7	4 x 90°	26.7
1½	127	222	98.6	17.5	15.7	4 x 90°	40.9
2	152	254	120.7	19.1	19.1	4 x 90°	52.6
2½	178	276	139.7	22.3	19.1	4 x 90°	62.7
3	190	298	152.5	23.9	19.1	4 x 90°	78.0
4	229	352	190.5	23.9	19.1	8 x 45°	102.4

DTS 1000273772 EN Version: S Status: RL (released | freigegeben | valide) printed: 28.02.2023

4.3. Body with thread connection

Note:

Dimensions in mm, unless otherwise stated

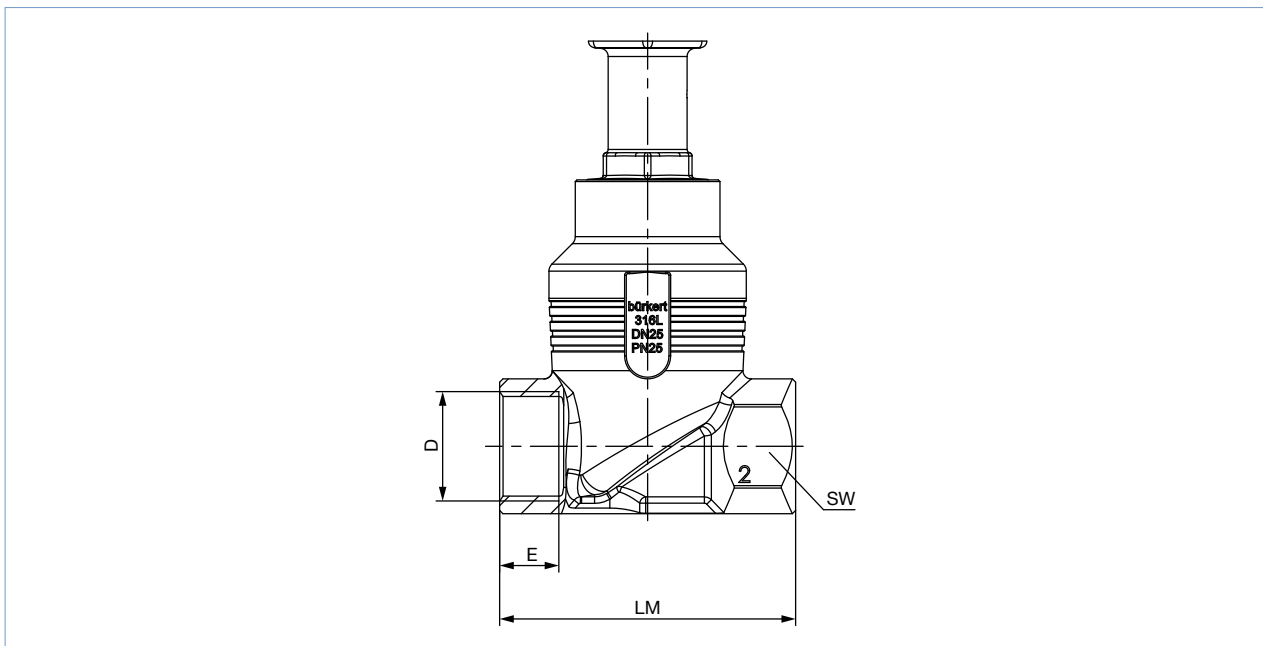

Nominal diameter (Pipe)	G, Rc, NPT (EN ISO 228 - 1, ISO 7/1/DIN EN 10226 - 2, ASME B 1.20.1)				LM	SW
	D	E	NPT	Rc		
DN	NPS	G	NPT	Rc		
10	3/8	12	10.3	10.1	65	27
15	1/2	14	13.7	13.2	65	27
20	3/4	16	14	14.5	75	34
25	1	18	16.8	16.8	90	41
32	1 1/4	20	17.3	19.1	110	50
40	1 1/2	22	17.3	19.1	120	55
50	2	24	17.6	23.4	150	70
65	2 1/2	26	23.7	26.7	185	85
80	3	28	30.5	29.8	205	100
100	4	32	33	35.8	240	125

4.4. Body with weld connection

Note:

Dimensions in mm, unless otherwise stated

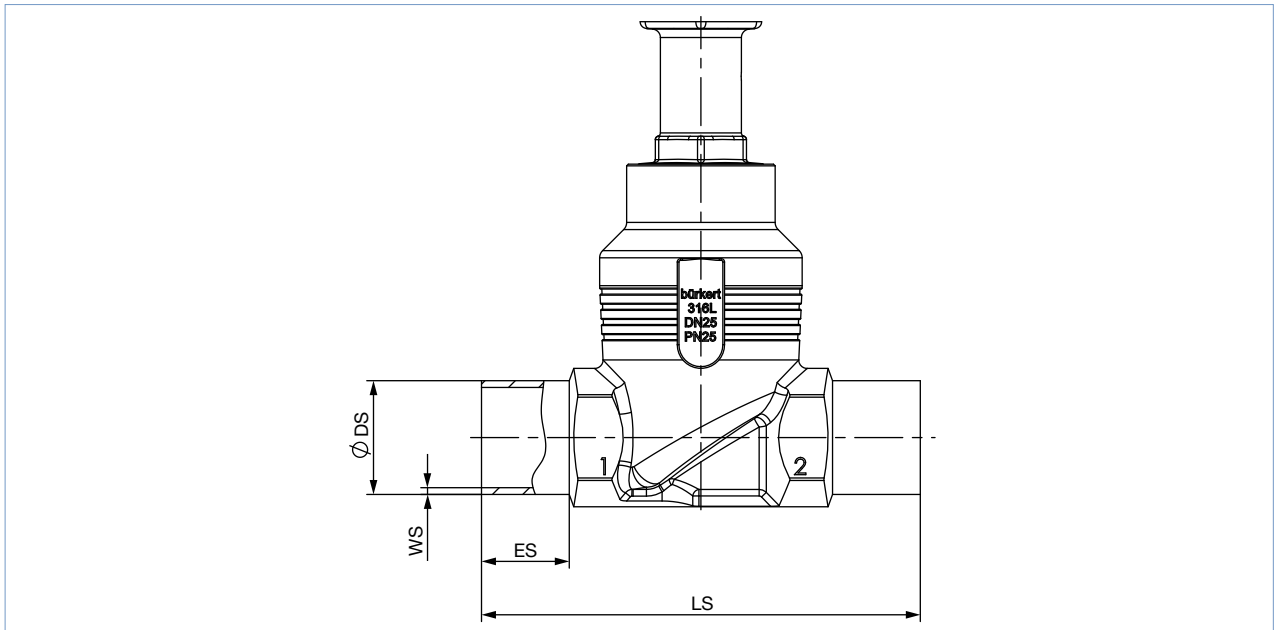

Nominal diameter (Pipe) DN	ES	LS	EN ISO 1127 1, ISO 4200/DIN 11866 B		DIN 11850 2, DIN 11866 A, DIN EN 10357 A	
			ØDS	WS	ØDS	WS
10	20	90	17.2	1.6	13	1.5
15	20	90	21.3	1.6	19	1.5
20	20	100	26.9	1.6	23	1.5
25	26	130	33.7	2.0	29	1.5
32	26	140	42.4	2.0	35	1.5
40	26	150	48.3	2.0	41	1.5
50	26	175	60.3	2.0	53	1.5
65	26	210	76.1	2.3	70	2.0
80	26	230	88.9	2.3	85	2.0
100	26	260	114.3	2.6	104	2.0

Nominal diameter (Pipe) NPS	ES	LS	ASME BPE, DIN 11866 C	
			ØDS	WS
½	20	90	12.7	1.65
¾	20	90	19.05	1.65
1	20	100	25.4	1.65
1½	26	140	38.1	1.65
2	26	150	50.8	1.65
2½	26	175	63.5	1.65
3	26	210	76.2	1.65
4	26	260	101.6	2.11

DTS 1000273772 EN Version: S Status: RL (released | freigegeben | validé) printed: 28.02.2023

4.5. Body with clamp connection

Note:

Dimensions in mm, unless otherwise stated

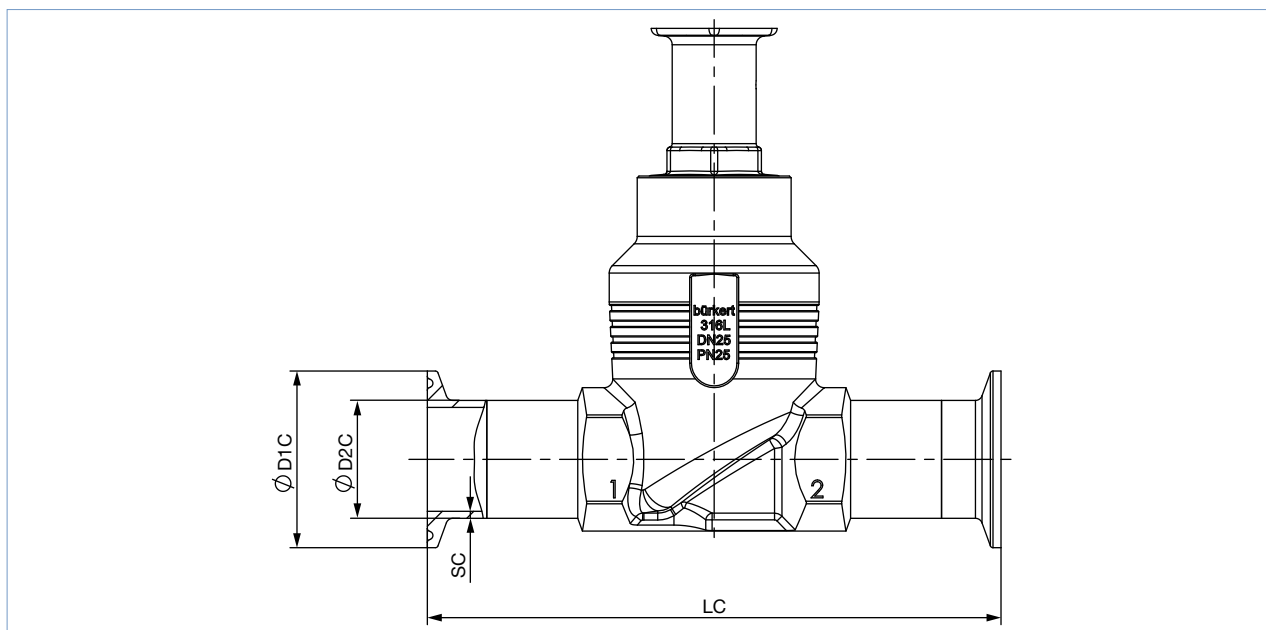

Nominal diameter (Pipe)	Clamp: DIN 32676 A Pipe: DIN 11850 2, DIN 11866 A, DIN EN 10357 A				Clamp: DIN 32676 B Pipe: EN ISO 1127 1, ISO 4200, DIN 11866 B			
	LC	ØD2C	ØD1C	SC	LC	ØD2C	ØD1C	SC
15	126	19	34	1.5	146	21.3	50.5	1.6
20	136	23	34	1.5	136	26.9	50.5	1.6
25	173	29	50.5	1.5	164	33.7	50.5	2.0
32	179	35	50.5	1.5	-	-	-	-
40	193	41	50.5	1.5	193	48.3	64.0	2.0
50	218	53	64	1.5	218	60.3	77.5	2.0
65	266	70	91	2.0	266	76.1	91	2.0
80	-	-	-	-	286	88.9	106	2.3
100	-	-	-	-	316	114.3	130	2.3

Nominal diameter (Pipe)	LC	Clamp: ASME BPE, DIN 32676 C Pipe: ASME BPE, DIN 11866 C		
NPS		ØD2C	ØD1C	SC
½	122	12.7	25.0	1.65
¾	126	19.05	25.0	1.65
1	126	25.4	50.5	1.65
1½	172	38.1	50.5	1.65
2	182	50.8	64.0	1.65
2½	231	63.5	77.5	1.65
2½	231	63.5	77.5	1.65
3	265	76.2	91.0	1.65
4	315	101.6	119.0	2.11

DTS 1000273772 EN Version: S Status: RL (released | freigegeben | valide) printed: 28.02.2023

5. Performance specifications

5.1. Fluidic data

Flow characteristics

- Flow characteristic acc. to DIN EN 60534-2-4
- Theoretical rangeability: K_{VS}/K_{V0} (see [“Overview of flow characteristics with flow below seat” on page 17](#))
- K_{VR} value^{1.)} at 5 % of stroke for seat size > 10
- K_{VR} value at 10 % of stroke for seat size ≤ 10
- The globe control valve has different flow characteristics and theoretical rangeabilities depending on the seat size (see [“Overview of flow characteristics with flow below seat” on page 17](#))
 - equal percentage or linear
 - 10:1, 25:1, 50:1

1.) K_{VR} value = smallest K_V value at which the inclination tolerance according to DIN EN 60534-2-4 can still be maintained.

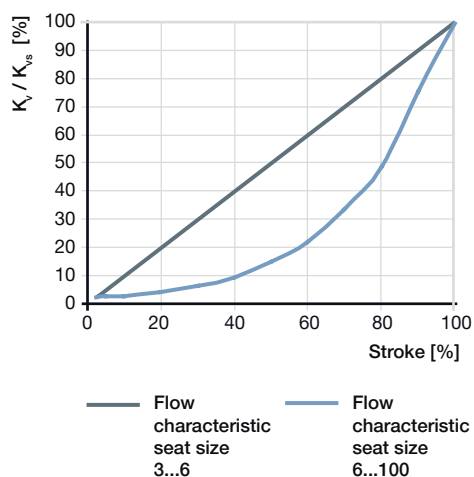

Overview of flow characteristics with flow below seat

Note:

- K_v value [m^3/h]: Measured with water acc. to DIN EN 60534-2-4
- Operating limits, see "5.2. Operating limits" on page 19

Nominal diameter (Pipe)		Seat size	Actuator force ^{1.)}	Operating pressure (Seat leakage class)			Charac-teristics (theoretical rangeability)	K_v value at stroke						K_{vs} value					
				Valve seat seal				5%	10%	30%	50%	70%	90%						
DN	NPS		[N]	Stain-less steel	PTFE	PEEK	[m ³ /h]						[m ³ /h]						
				[bar(g)]															
10	3/8 ^{2.)}	3	1300	25 (IV)	-	-	Linear (10:1)	-	0.003	0.015	0.037	0.065	0.090	0.10					
		4					Linear (25:1)	-	0.015	0.1	0.19	0.27	0.33	0.35					
		4					Linear (10:1)	-	0.050	0.16	0.27	0.36	0.44	0.50					
		6					Linear (25:1)	-	0.12	0.48	0.76	0.98	1.1	1.2					
		6					25 (VI)	Equal percentage (50:1)	-	0.007	0.045	0.16	0.41	1.1	1.25				
		8						-	0.070	0.12	0.26	0.61	1.5	2.0					
		10						-	0.11	0.19	0.48	1.0	2.3	2.7					
15	1/2 ^{2.)}	3	1300	25 (IV)	-	-	Linear (10:1)	-	0.003	0.015	0.037	0.065	0.09	0.10					
		4					Linear (25:1)	-	0.015	0.1	0.19	0.27	0.33	0.35					
		4					Linear (10:1)	-	0.050	0.16	0.27	0.36	0.44	0.50					
		6					Linear (25:1)	-	0.12	0.48	0.76	0.98	1.1	1.2					
		6					25 (VI)	Equal percentage (50:1)	-	0.007	0.045	0.16	0.41	1.1	1.25				
		8						-	0.080	0.13	0.27	0.63	1.6	2.1					
		10						-	0.11	0.19	0.49	1.1	2.5	3.1					
20	3/4 ^{2.)}	10	1300	25 (IV)	-	25 (VI)	0.14	0.17	0.35	0.80	1.8	3.7	4.3						
		15					-	0.12	0.20	0.52	1.2	2.6	3.2						
		20					0.14	0.17	0.35	0.80	1.8	4.0	5.2						
25	1 ^{2.)}	15	1300	25 (IV)	-	25 (VI)	0.20	0.25	0.45	1.1	2.4	5.2	7.1						
		20					0.14	0.17	0.35	0.80	1.8	4.1	5.3						
		25					0.20	0.25	0.47	1.1	2.5	5.4	7.2						
32	1 1/4 ^{2.)}	20	1300	25 (IV)	25 (VI)	25 (VI)	0.35	0.38	1	2.2	5.1	9.4	12						
		25					0.22	0.25	0.50	1.1	2.5	5.8	8						
		32					0.40	0.47	1.1	2.5	5.4	10.3	13						
		2500					0.48	0.60	1.3	3.1	6.8	14.0	17.8						
							16 (IV)	16 (VI)	10 (VI)										
40	1 1/2 ^{2.)}	25	1300	25 (IV)	25 (VI)	20 (VI)	0.40	0.50	1.1	2.6	5.6	10.7	13.6						
		32					0.48	0.60	1.3	3.2	6.9	15.0	20						
		2500					25 (IV)	25 (VI)	20 (VI)										
							40	1300	10 (III)	10 (VI)	6 (VI)	0.60	0.70	1.7	4.0	9.2	18.2	24	
		50					2 ^{2.)}	32	1300	16 (IV)	16 (VI)	10 (VI)	0.48	0.60	1.3	3.2	6.9	16.0	21
								40					2500	25 (IV)	25 (VI)	20 (VI)	0.60	0.70	1.7
1300	10 (III)		10 (VI)	6 (VI)															
7700	25 (IV)		-	25 (VI)															
7700	25 (IV)	6 (III)	6 (VI)	-	0.90	1.1	2.9	6.8	15.5	29	37								
		10 (III)	10 (VI)	8 (VI)															
		25 (IV)	-	25 (VI)															

Nominal diameter (Pipe)		Seat size	Actuator force ^{1.)}	Operating pressure (Seat leakage class)			Charac-teristics (theoretical rangeability)	K _v value at stroke						K _{vs} value
				Valve seat seal				5 %	10 %	30 %	50 %	70 %	90 %	
DN	NPS		[N]	Stain-less steel	PTFE	PEEK	[m³/h]						[m³/h]	
				[bar(g)]										
65	2½ ^{2.)}	40	10000	25 (IV)	-	-	Equal percentage (50:1)	0.45	0.55	1.3	3.1	6.8	17.2	25.5
		50						0.75	0.9	2.3	4.9	11	26	39.5
		65				25 (VI)		1.1	1.4	3.2	8	18.5	46.5	62
80	3 ^{2.)}	50		25 (IV)	-	-		0.85	1	2.3	5	10.5	25	42
		65				25 (VI)		1.4	1.7	3.8	8.2	19.5	50	70
		80				21 (IV)		2.1	2.6	7	16	40	83	100
100	4 ^{2.)}	65		25 (IV)	-	25 (IV)		1.4	1.7	3.8	8.3	20	51	75
		80				21 (IV)		2.1	2.6	7	17	44	89	115
		100				13.5 (III)		3.2	3.9	9	20.5	51	118	140

1.) AG2: Actuator size 2 with a nominal force of 1300 or 2500 N

AG3: Actuator size 3 with a nominal force of 7700 or 10000 N

2.) Deviation for line connections according to ASME BPE: the next larger nominal connection size is used, e.g. NPS 1 instead of NPS ¾

5.2. Operating limits

Operating limits for medium temperature and operating pressure

The operating range of Bürkert process valves is in addition to the maximum operating pressures limited by the nominal pressure according to the relevant standard.

Application limits of operating pressure and medium pressure

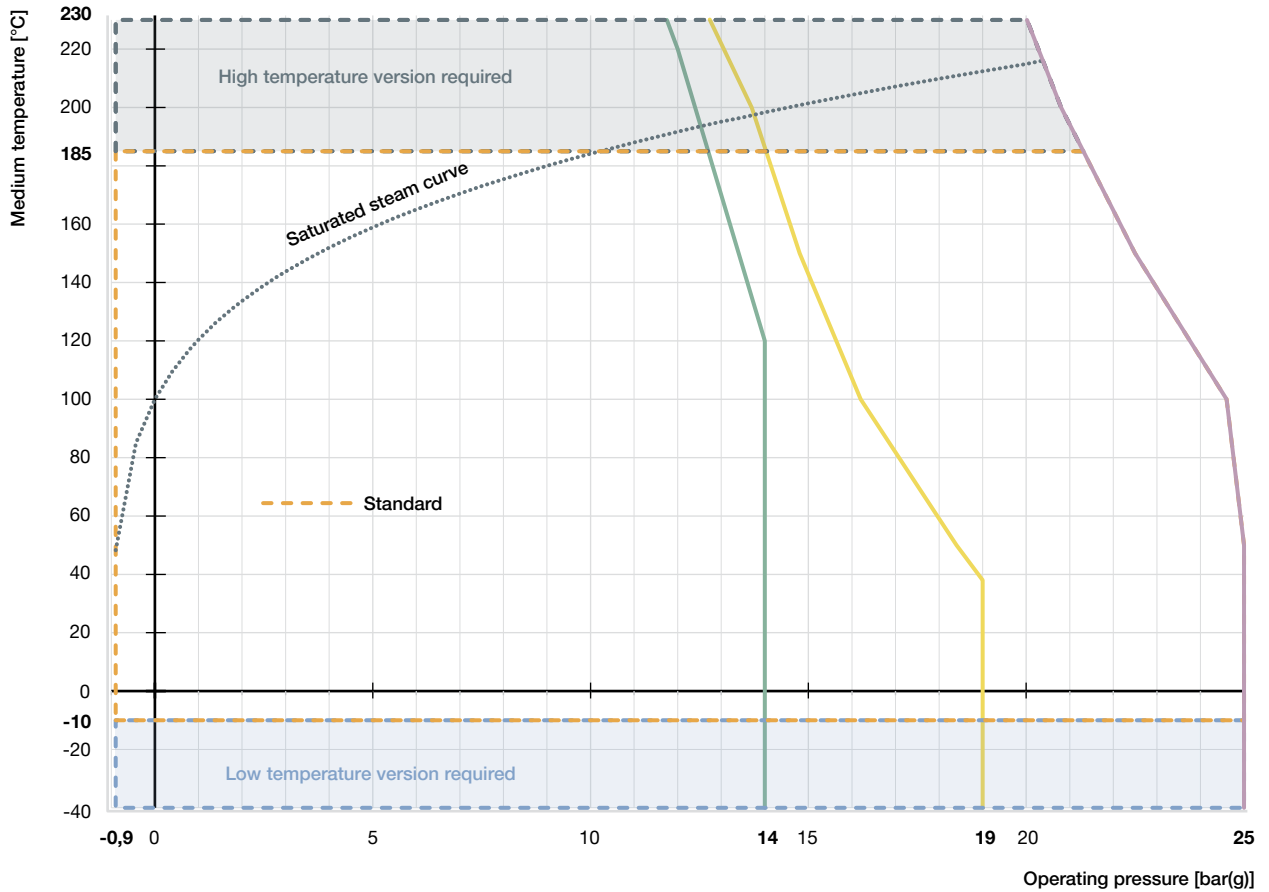

- Operating limits for PN25 acc. to DIN EN 12516-1
- Operating limits for flange 10K acc. to JIS B 2220
- Operating limits for Class 150 acc. to ASME B16.34
- Saturated steam curve for water

Operating limits for ambient and medium temperature

The maximum permissible temperature for the environment and the medium are dependent on each other. The maximum allowable temperature curves of different device variants can be seen in the temperature chart. The curves were determined for maximum operating conditions (max. operating pressure and motor power). For deviating operating conditions an individual verification can be performed. Please contact your Bürkert office for more information.

AG2

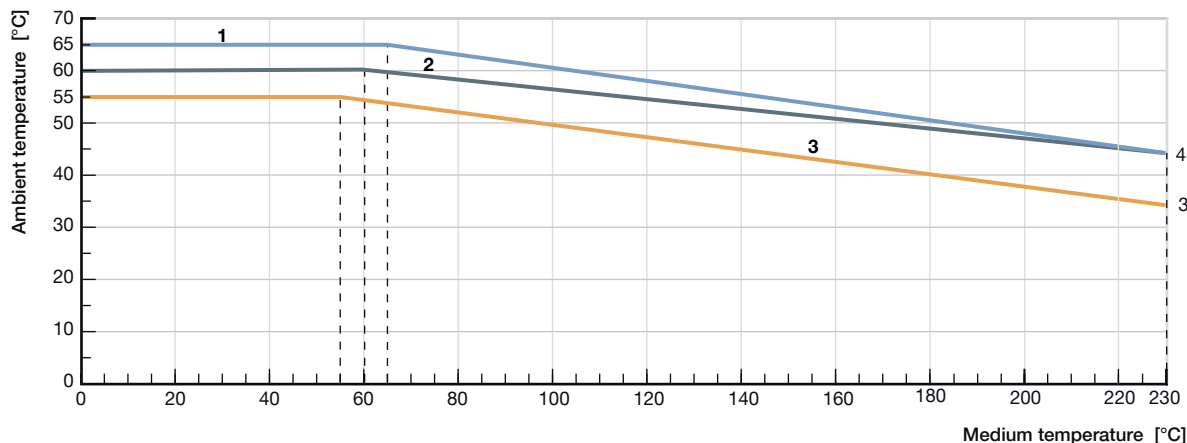

No.	Description
1	Devices without module
2	Devices with display
3	Devices with SAFEPOS energy-pack or fieldbus gateway, with/without display module

AG3

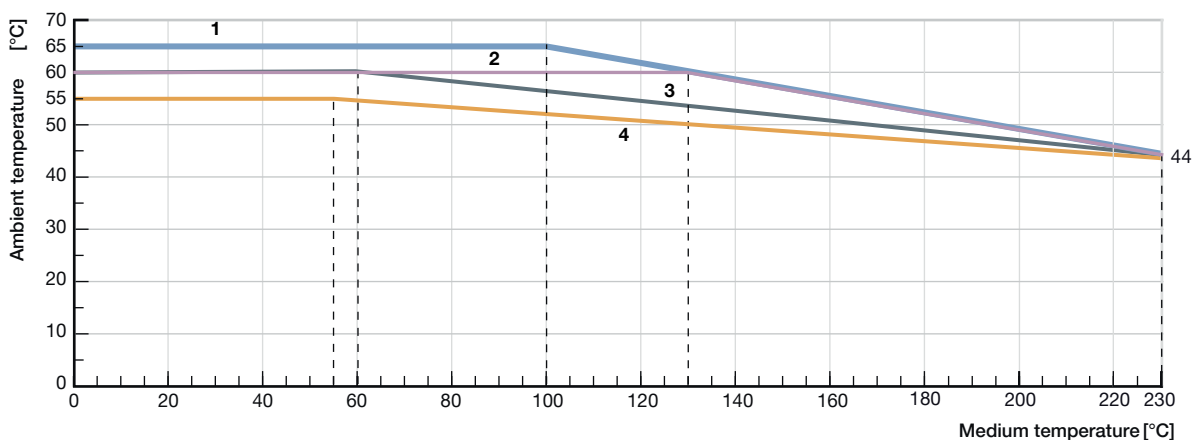

No.	Description
1	Devices without module
2	Devices with SAFEPOS energy-pack
3	Devices with display module with/without SAFEPOS energy-pack
4	Devices with fieldbus gateway with/without display module with/without SAFEPOS energy-pack

DTS 1000273772 EN Version: S Status: RL (released | freigegeben | valide) printed: 28.02.2023

Operating limits for seat seal

Tight sealing required	Leakage class (DIN EN 60534 - 4)	Medium temperature	Seat seal
No An additional shut-off valve is recommended	III/IV (metal seals) Metal-sealed valves have larger leakages (0.1 % or 0.01 % of the nominal flow rate are permissible). Metallic seals are impervious even under demanding process conditions.	-40...230 °C	Stainless steel
	For particularly demanding process conditions such as cavitation, erosion by wet steam or abrasive media, hardened cones and seats, can be used to significantly increase the service life.		Hardened stainless steel
Yes An additional shut-off valve is often unnecessary.	VI (soft seals) By using plastics as sealing material, the control valves can close tightly.	-40...130 °C (recommended for ≤ 130 °C)	PTFE
	Their use is not recommended in cases of increased erosion due to demanding process conditions.	-10...230 °C (recommended for > 130 °C)	PEEK

Operating limits for optional versions

High temperature version

By adapting the spindle sealing this version is suitable for applications with steam, neutral gases and other heat transfer mediums up to 230 °C.

Drinking water version

Materials in contact with the medium are tested for suitability with drinking water up to 85 °C.

Vacuum version

Without leakage bore, this design is suitable for pressures down to -0.9 bar(g).

Low temperature version

Suitable for minimum medium temperatures down to -40 °C

Version for oxygen

Non-metallic materials in contact with the medium are tested for suitability with oxygen. Suitable for operating pressures up to 25 bar(g) and medium temperatures up to 60 °C.

5.3. Electrical control and interfaces

Interface diagram

The position of the actuator is controlled according to the position setpoint. The position setpoint is given either by an external standard signal (analogue) or via a fieldbus (digital).

Analogue control

For the analogue control 2 variants each are available for the inputs and outputs and the connection interface.

Inputs and outputs:

- 1 analogue input, 1 digital input
- 1 analogue input, 1 digital input, 1 analogue output, 2 digital output (optional)
- 1 analogue input process actual value (for optional version with process controller)

Interface:

- Cable gland with connection terminal (only AG2)
- M12 circular plug-in connectors (optional)

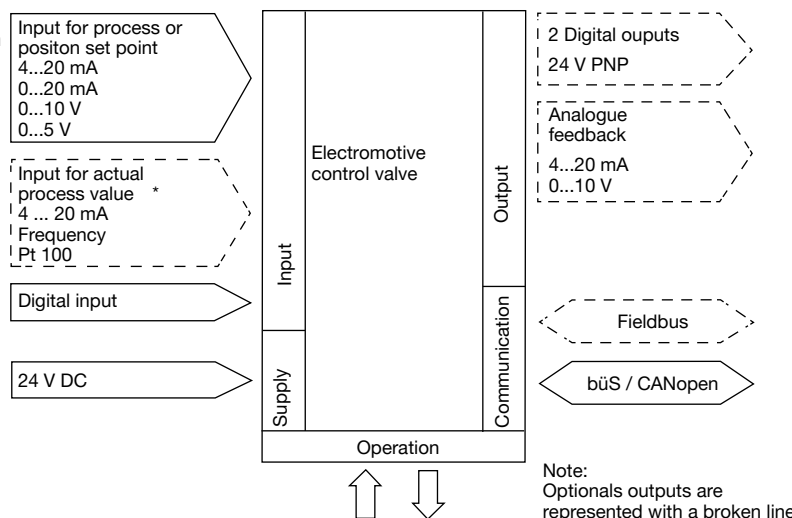

Control data	
Analogue setpoint input	Galvanically isolated from supply voltage and analogue output 0/4...20 mA (input resistance < 70 Ω) 0...5/10 V (input resistance 22 kΩ)
Analogue output	Max. current 10 mA (for voltage output 0...5/10 V) Burden (load) 0...800 Ω (for current output 0/4...20 mA)
Digital input	0...5 V = log "0", 10...30 V = log "1" inverted input reversed accordingly
Digital output	PNP, Current limitation 100 mA
Analogue actual value signal input (optional)	
4...20 mA	Input resistance: < 70 Ω Resolution: 12 Bit
Frequency	Measuring range: up to 1000 Hz Input resistance: > 30 kΩ Resolution: 0.1 % of measured value Input signal: > 300 mVss Signal shape: sine, rectangle, triangle
Pt 100	Measuring range: -20 °C...+220 °C Resolution: 0.01 °C Measuring current: 1 mA
Communication	
Communication interface (büS)	Connection to PC via USB büS interface set
Communication software (büS)	Bürkert Communicator, see Type 8920 ▶

6. Product design and assembly



6.1. Product features

Note

More detailed information can be found in the **operating instructions** ►.

User interface	
<p>Device without display module: In the version without operating display, the basic functions are operated via 4 DIP switches and 2 push buttons. These are located under the blind cover, which can be removed by turning it manually. The device can also be configured in detail with the Bürkert Communicator software via the bÜS service interface. The buttons and switches are inactive for version with optional display module</p>	<p style="text-align: right;">Blind cover dismantled</p>
<p>Rugged Touch Display (optional): The robust display module offers convenient operation, configuration and display of all necessary functions. Besides the start screen, various views can be freely configured. The bÜS service interface is also available here under the display module. The display cannot be retrofitted in the field..</p>	
Actuation	
<p>Mechanical manual control: The manual override for mechanical movement of the valve is located for AG2 under the blind cover or display module and for AG3 under the pressure compensation element. It ensures that the actuator can be operated even if the power supply fails.</p>	
<p>Electrical control via operating elements: The electrical manual override for operation can be carried out directly on the touch display or, in the version without display, via two buttons under the blind cover.</p>	
Display elements	
<p>Display 360° LED light ring: A clearly visible 360° LED ring is attached to the blind cover or display module to indicate the device status, the valve end position and the operating status. The LED light ring lights up, blinks or flashes into one or changing colours, depending on the LED mode set</p> <p>Mechanical position indicator: The mechanical position indicator shows the current valve position even if the supply voltage fails.</p>	
Data transmission (optional)	
<p>SIM card (optional): With the optionally available SIM card, device-specific values and user settings can be stored and quickly transferred to another device.</p>	

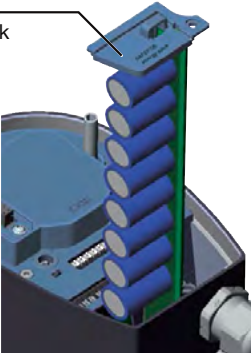
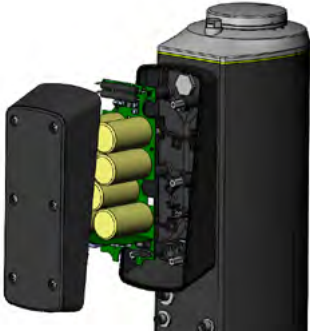
DTS 1000273772 EN Version: S Status: RL (released | freigegeben | validé) printed: 28.02.2023

Safety position via energy storage (optional)	AG2	AG3
<p>The safety starting positions in case of power interruption is realized with the optional energy storage SAFEPOS energy-pack. The desired position is set via the menu. In addition to the end positions (open/closed), any desired intermediate position can be defined here. The energy storage has a lifespan of up to 10 years, depending on the operating conditions. The power of the energy storage is monitored and a warning is displayed to indicate its life is coming to an end. The storage device is designed as a plug-in module to facilitate replacement. Without energy storage, the valve remains in the last position it was in. The energy storage device is fully charged and ready for operation after a maximum of 120 seconds (depending on the operating conditions). The energy storage device cannot be retrofitted in the field.</p>	 <p>SAFEPOS energy-pack</p>	
Fieldbus: EtherNet/IP, PROFINET, Modbus TCP (optional)		
<p>The fieldbus gateway for EtherNet/IP, PROFINET and Modbus TCP is integrated in an additional module. It has 2 fieldbus connections with 4 pin M12 circular sockets. The interfaces for the fieldbus connection and the status LEDs are located under the gateway housing cover. If there is a need for it to be include in a network then the configuration of the Ethernet can be performed via the web server. The gateway cannot be retrofitted in the field.</p>	 <p>Display module</p> <p>Fieldbus gateway</p> <p>Fieldbus M12 connection (2 Port Ethernet Switch)</p>	

DTS 1000273772 EN Version: S Status: RL (released | freigegeben | valide) printed: 28.02.2023

6.2. Product assembly

The electromotive linear drive consists of a brushless DC motor, a gear and a spindle system that transfers the force to the control cone. The integrated control electronics are controlled either by standard signals (analogue) or via a field bus (digital). A positioner and a process controller are available as controller versions. The electromotive linear actuator is designed to provide optimum efficiency. At the same time, it keeps the valve tight and in position even at the maximum specified medium pressure in a powerless standstill. An optional energy storage device (SAFEPOS energy-pack) is available for the device. If the supply voltage fails, it supplies the actuator with the energy required to move the valve into the desired position, which can be set in the menu.

The valve position can be changed manually in 2 ways. Either via the electrical manual control or via a mechanical manual control if no supply voltage is available. The device can be set and operated either via 2 capacitive keys and 4 DIP switches or optionally on a display with touch screen. In addition there is always the possibility to operate the device via the bÜS service interface and using the "Bürkert Communicator" software.

The intelligent process valve Type 3361 offers the operator options for process monitoring, valve diagnosis and preventive maintenance. Internal measurements of the operating status are evaluated and, if necessary, issued as a warning or error message. These signal, for example, impermissible ambient and process conditions, functional deviations of components or the status of the energy storage device. A special feature of the Globe Control Valve is the screwed-in valve seat, which can be replaced to reduce the seat size

AG2

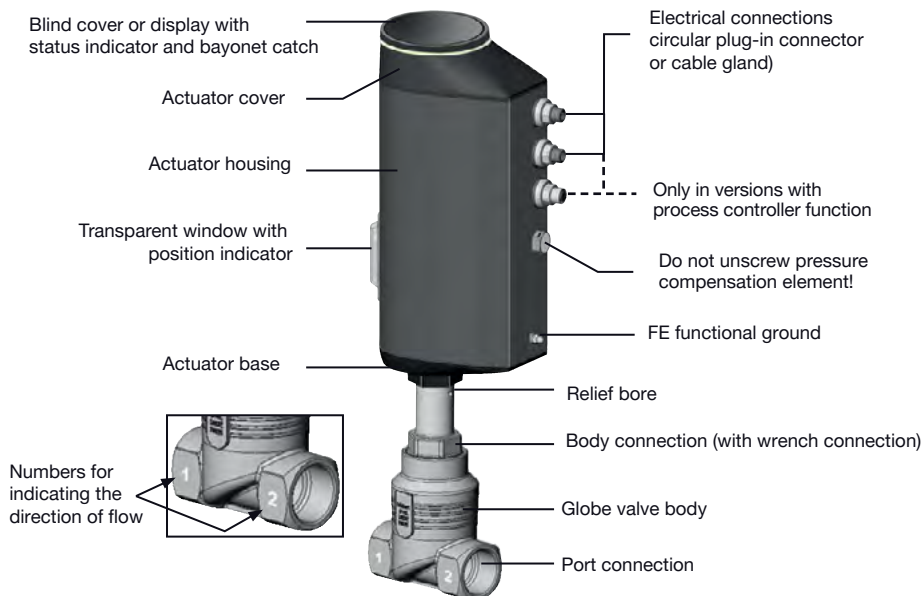

AG3

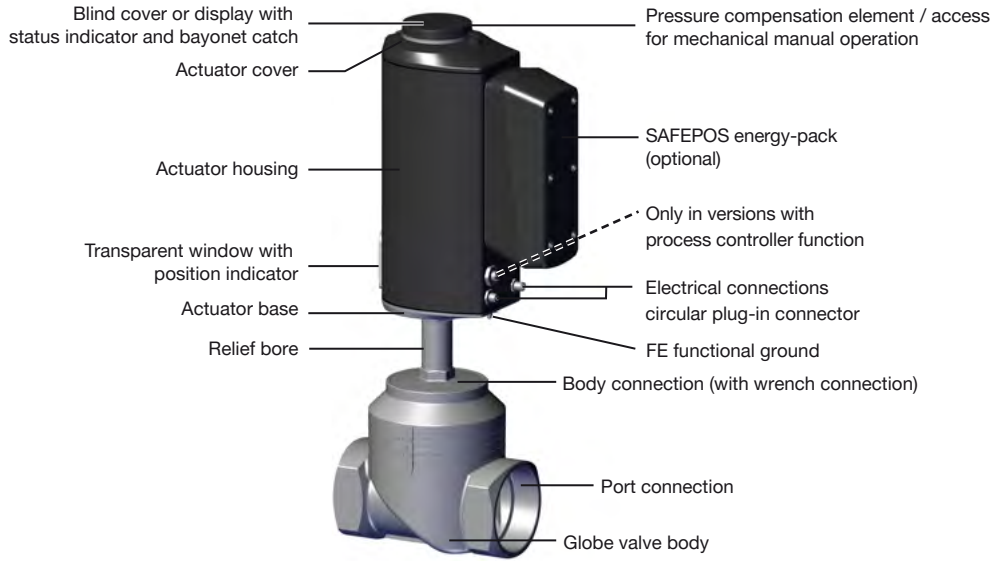

Integrated position controller

The position of the actuator (stroke) is controlled according to the position setpoint. The position setpoint is either given by an external standard signal (analogue) or via a fieldbus (digital). The displacement transducer records the actual position (POS) of the electric linear actuator. This actual position value is compared by the positioner with the position setpoint (CMD) specified as standard signal. If there is a system deviation (Xd1), the electric motor drive is controlled via the manipulated variable CTRL and the actual position value is changed accordingly.

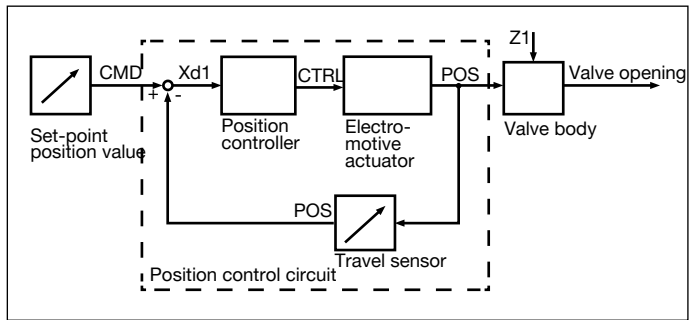

Integrated process controller (optional)

The additionally implemented PID controller allows process control. The setpoint position of the valve is calculated from the external signal (e.g. level, pressure, flow rate, temperature) for the process setpoint and the actual process value via the control parameters (PID controller).

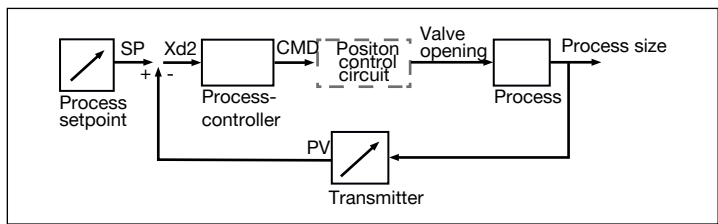

DTS 1000273772 EN Version: S Status: RL (released | freigegeben | valide) printed: 28.02.2023

7. Ordering information

7.1. Bürkert eShop – Easy ordering and quick delivery



Bürkert eShop – Easy ordering and fast delivery

You want to find your desired Bürkert product or spare part quickly and order directly? Our online shop is available for you 24/7. Sign up and enjoy all the benefits.

[Order online now](#)

7.2. Bürkert product filter









Bürkert product filter – Get quickly to the right product

You want to select products comfortably based on your technical requirements? Use the Bürkert product filter and find suitable articles for your application quickly and easily.

[Try out our product filter](#)

7.3. Ordering chart accessories





Standard accessories

Description	Article no.
SIM card for data transmission between devices	291773 
Holding device for port connection DN 15...20	693770 
Holding device for port connection DN 25...50	693771 
Plastic blind cover	277881 
Energy storage SAFEPOS energy-pack (AG2)	285834 
Energy storage SAFEPOS energy-pack (AG3)	20046438 

Accessories cable

Note:



For connection to a bus/CANopen network see [cabling guide](#) ►.

Description	Article no.
Connection cable with M12 socket, 4 pin, (length 5 m) for operating voltage AG2 (without communication)	918038 
Connection cable with M12 socket, 5 pin, L coded (length 5 m) for operating voltage AG3 (without communication)	20010840 
Connection cable with M12 socket, 8 pin, (length 2 m) for input and output signals	919061 
Connection cable with M12 plug, 5 pin, (length 2 m) for input of process actual value signals (only for version with process controller)	559177 

Bürkert accessories

Note:

- For connection to a bus/CANopen network see **cabling guide** ▶.
- Detailed accessory tables can be found in the cabling guide

Description	Article no.
Software Bürkert Communicator, Type 8920	LINK ▶
büS stick set 1 (including power supply unit, bus-stick, terminating resistor, Y-distributor, 0.7 m cable with M12 connector)	772426 
büS stick set 2 (including bus-stick, terminating resistor, Y-distributor, 0.7 m cable with M12 connector)	772551 
büS adapter for büS interface set (M12 on büS service interface Micro-USB)	773254 

7.4. Bürkert product enquiry form

Bürkert product enquiry form: Would you like to make a specific product enquiry based on your technical requirements? Please use our product enquiry form **at the end of this data sheet**. There you will find all the information relevant to your Bürkert contact person that will help us to process your enquiry in the best possible way.

Bürkert specification key: In our product enquiry form you will find a complete explanation of the composition of our specification key. You will find our product enquiry form **at the end of this data sheet**.

Bürkert – Close to You

For up-to-date addresses
please visit us at
www.burkert.com

DTS 1000273772 EN Version: S Status: RL (released | freigegeben | validé) printed: 28.02.2023



