



Direct-acting 3/2-way plunger valve

- Direct-acting and compact small valve up to DN 1.6
- Slipped over coil system
- Banjo fitting for direct mounting on pneumatic valves
- Simple and fast push-in, flange or manifold mounting
- Explosion-proof variants



Product variants described in the data sheet may differ from the product presentation and description.

Type description

The 7012 valve is a direct-acting plunger valve. The stopper and the core guide tube are welded together to increase pressure resistance and leak-tightness. Various housing and seal material combinations are available depending on the actual application. A Bürkert-specific flange variant (SFB) enables the space-saving arrangement of valves on a multiple manifold. The range is supplemented by explosion-proof variants. Push-in fittings can be selected for a flexible hose connection. A banjo fitting with banjo bolt is the ideal solution for easy direct mounting on a pneumatic actuator. Optional manual override enables quick start-up and optimal maintenance. In combination with a plug to industry standard shape B or DIN EN 17301-803 shape C, the valves satisfy degree of protection IP65.

Table of contents

1. General technical data	3
2. Circuit functions	4
3. Approvals	4
4. Materials	5
4.1. Chemical Resistance Chart – Bürkert resistApp.....	5
4.2. Material specifications	5
Standard version.....	5
ATEX/IECEX cable version	6
Banjo version	7
5. Dimensions	8
5.1. Standard version.....	8
Threaded version	8
Flange version.....	8
5.2. ATEX-/IECEX cable version.....	9
Threaded version	9
Flange version.....	10
PIN Assignments	10
Versions according to industry standard form B	11
Further electrical connections.....	11
5.3. Banjo version	12
Versions according to industry standard form B, coil size 24.5 mm	12
5.4. Multiple manifold	12
6. Performance specifications	13
6.1. Power consumption of standard coil version 24.5 mm	13
6.2. Power consumption of standard coil version 20 mm	13
7. Ordering information	14
7.1. Bürkert eShop – Easy ordering and quick delivery.....	14
7.2. Bürkert product filter	14
7.3. Ordering chart.....	14
Standard version according to industry standard form B, coil size 24.5 mm.....	14
Standard version according to industry standard form B, coil size 20 mm.....	16
Banjo version, coil size 24.5 mm	18
ATEX/IECEX version	19
Additional options	19
7.4. Ordering chart accessories.....	20
Multiple manifolds.....	20
Accessories for manifolds	20
Cable plug Type 2516, form C according to DIN EN 175301 - 803.....	20
Cable plug Type 2507, form B according to industry standard	20

1. General technical data

Product properties	
Dimensions	Detailed information can be found in chapter "5. Dimensions" on page 8.
Material	
Seal	FKM, EPDM
Body	Brass, polyamide (PA), stainless steel 1.4305
Manual override	Optional, standard for Type 7012 banjo version
Weight	
Standard version 24.5 mm solenoid coil	146 g (with G 1/8)
Standard version 20 mm solenoid coil	120 g (with G 1/8)
Banjo version	135 g
Circuit function	C and D. Detailed information can be found in chapter "2. Circuit functions" on page 4.
Thermal insulation class of solenoid coil	Epoxy: class H
Performance data	
Duty cycle	
Single valve	Continuous operation 100 % ED resp. 50 % ED
For block mounting on multiple manifold	With 4 W/5 W solenoid coil 100 % ED (at max. 55 °C)
Switching time ^{1.)}	
Standard version	Orifice 1.2...1.6 mm: opening 8...12 ms, closing 8...12 ms
Banjo version	Orifice 1.2 mm: opening 7...12 ms, closing 7...12 ms
Electrical data	
Operating voltage	24 V DC, 24 V / 50 Hz, 110 / 230 V / 50 Hz
Voltage tolerance	± 10 %
Medium data	
Operating medium	Neutral gases and fluids (e.g. compressed air, water, hydraulic oil, technical vacuum)
Medium temperature	
Standard version	-10 °C...+100 °C
Banjo version	-10 °C...+60 °C
Viscosity (max.)	21 mm ² /s
Process/Port connection & communication	
Electrical connection	<ul style="list-style-type: none"> • Acc. to DIN EN 175301-803 form C for cable plug Type 2516 • Acc. to industry standard form B for cable plug Type 2507 • Flat pin terminal as protection class III device • Flying leads connection on request for coil size 20 mm • ATEX/IECEx version with 3 m moulded-in cable
Port connection	
Standard version	M5, G 1/8, Flange
Banjo version	G 1/8, G 1/4 and hose connector Ø 6 mm
Approvals and certificates	
Degree of protection	IP65 with cable plug and ATEX/IECEx cable connection version
Environment and installation	
Installation position	As required, preferably with actuator upright
Ambient temperature	
Standard version	Max. +55 °C resp. 75 °C, depending on power level
ATEX/IECEx version	Max. +55 °C (max. +60 °C on request)
Banjo version	-10 °C...+40 °C

1.) Measured at valve outlet at 6 bar and +20 °C according to ISO 12238, opening: pressure rise 0...10 %, closing: pressure drop 100...90 %

2. Circuit functions

Circuit functions	Description
	Type: C, solenoid valve 3/2 way Direct-acting Normally closed
	Type: D, solenoid valve 3/2 way Direct-acting Normally open

3. Approvals

Approvals	Description
	ATEX and IECEx approval for coils with fixed cable outlet ATEX: EPS 21 ATEX 1 128 X II 2G Ex mb IIC T4 Gb II 2D Ex mb IIIC T130 °C Db IECEx: IECEx EPS 21.0045X Ex mb IIC T4 Gb Ex mb IIIC T130 °C Db

4. Materials

4.1. Chemical Resistance Chart – Bürkert resistApp

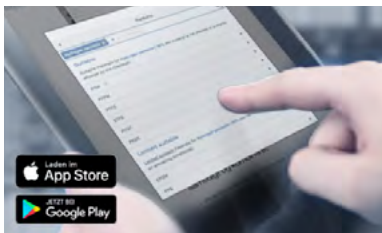

Bürkert resistApp – Chemical Resistance Chart

You want to ensure the reliability and durability of the materials in your individual application case? Verify your combination of media and materials on our website or in our resistApp.

[Start Chemical Resistance Check](#)

4.2. Material specifications

Standard version

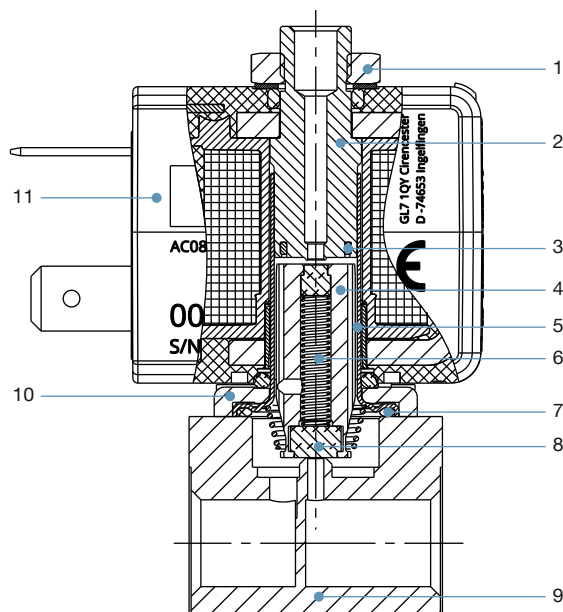

No.	Element	Material
1	Locknut	DIN 176 Surface finish thick film passivated KOSA0101
2	Stopper	Stainless steel 1.4113
3	Shading ring	Copper (silver optional)
4	Core	Stainless steel 1.4113
5	Guide tube	Stainless steel 1.4303
6	Spring	Stainless steel 1.4310
7	O-ring	FKM/EPDM
8	Seal	FKM/EPDM
9	Valve body	Brass, stainless steel 1.4305 PA (polyamide)
10	Flange	<ul style="list-style-type: none"> Surface finish thick film passivated KOSA0101 (brass version) Nickel-plated surface (stainless steel version)
11	Coil	Epoxy

ATEX/IECEX cable version

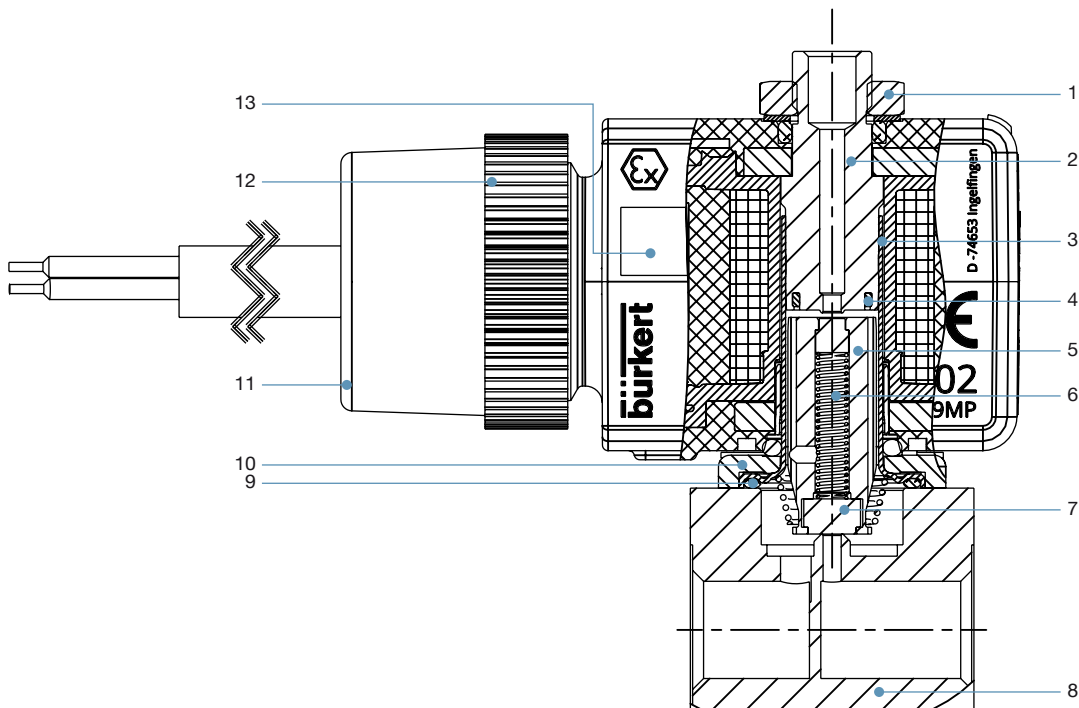

No.	Element	Material
1	Locknut	DIN 176 Surface finish thick film passivated KOSA0101
2	Stopper	Stainless steel 1.4113
3	Guide tube	Stainless steel 1.4303 ST
4	Shading ring	Copper, (optional silver)
5	Core	Stainless steel 1.4113
6	Spring	Stainless steel 1.4310
7	Seal	FKM/EPDM
8	Valve body	Brass, stainless steel 1.4305 PA (polyamide)
9	O-Ring	FKM/EPDM
10	Flange	<ul style="list-style-type: none"> • Surface finish thick film passivated KOSA0101 (brass version) • Nickel-plated surface (stainless steel version)
11	Sealing ring	Silicone
12	Union nut	PA (Polyamide)
13	Coil	Epoxy

DTS 1000446517 EN Version: F Status: RL (released | freigegeben | valide) printed: 15.09.2022

Banjo version

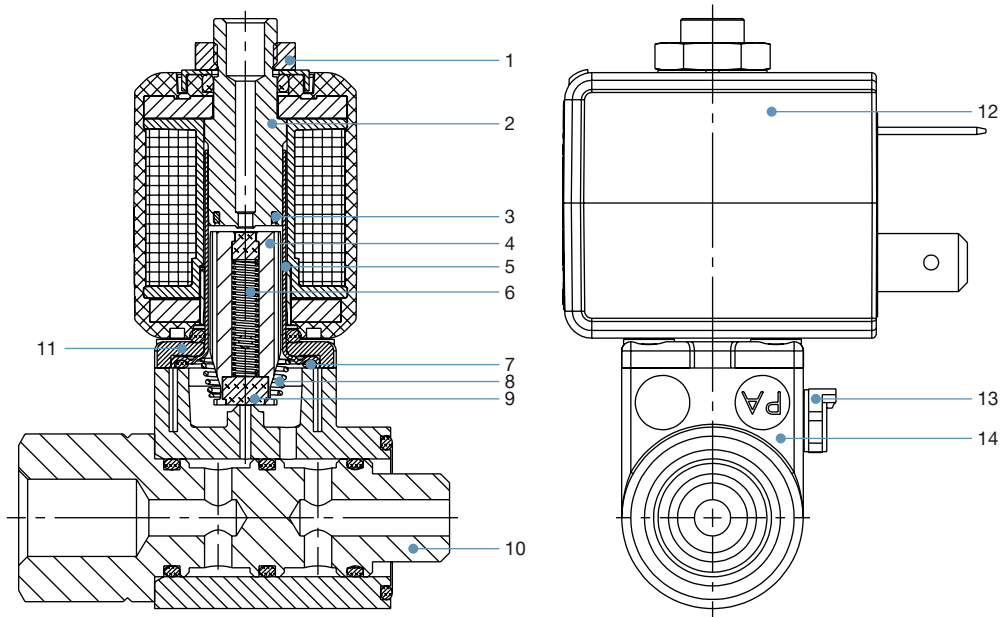

No.	Element	Material
1	Locknut	DIN 176 Surface finish thick film passivated KOSA0101
2	Stopper	Stainless steel 1.4113
3	Shading ring	Copper (silver optional)
4	Core	Stainless steel 1.4113
5	Guide tube	Stainless steel 1.4303 ST
6	Spring	Stainless steel 1.4310
7	O-ring	FKM
8	Spring	Stainless steel 1.4310
9	Seal	FKM
10	Banjo bolt	Nickel-plated brass
11	Flange	<ul style="list-style-type: none"> Surface finish thick film passivated KOSA0101 (brass version) Nickel-plated surface (stainless steel version)
12	Coil	Epoxy
13	Manual override	Durethan
14	Body	PA (polyamide)

DTS 1000446517 EN Version: F Status: RL (released | freigegeben | validé) printed: 15.09.2022

5. Dimensions

5.1. Standard version

Threaded version

Note:

- Dimensions in mm
- Versions according to industry standard form B

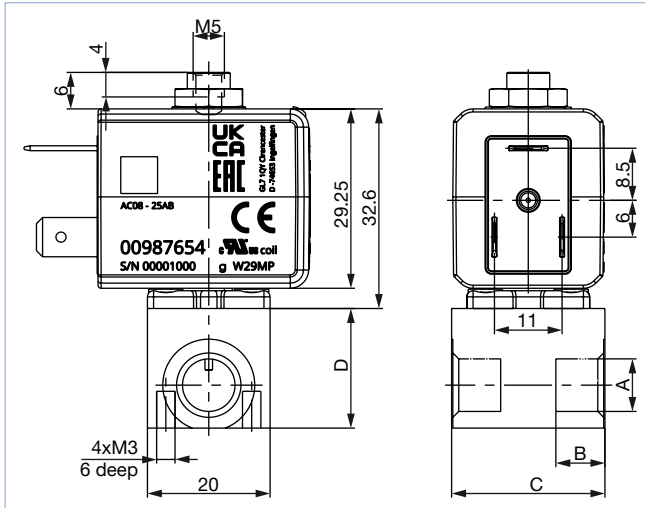

Port connection	A	B	C	D
Thread	M5	5	20	14
Thread	G 1/8	8	25	19.5

Flange version

Note:

- Dimensions in mm
- Versions according to industry standard form B

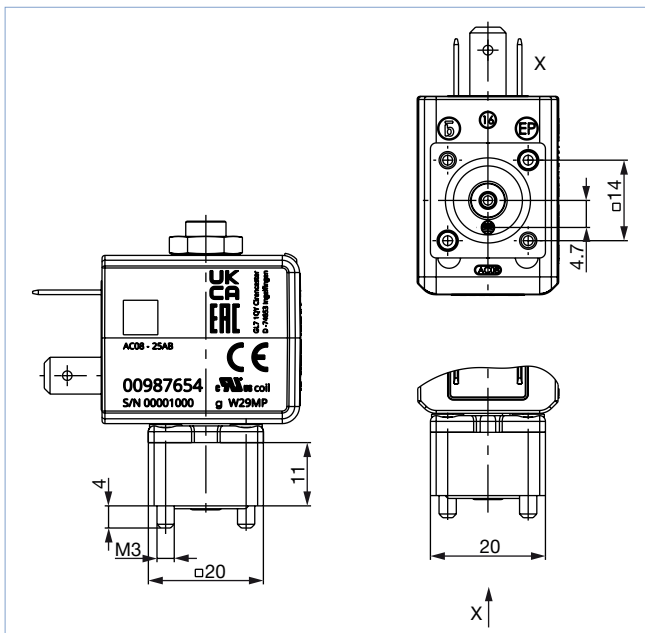

DTS 1000446517 EN Version: F Status: RL (released | freigegeben | valide) printed: 15.09.2022

5.2. ATEX-/IECEx cable version

Threaded version

Note:

Dimensions in mm

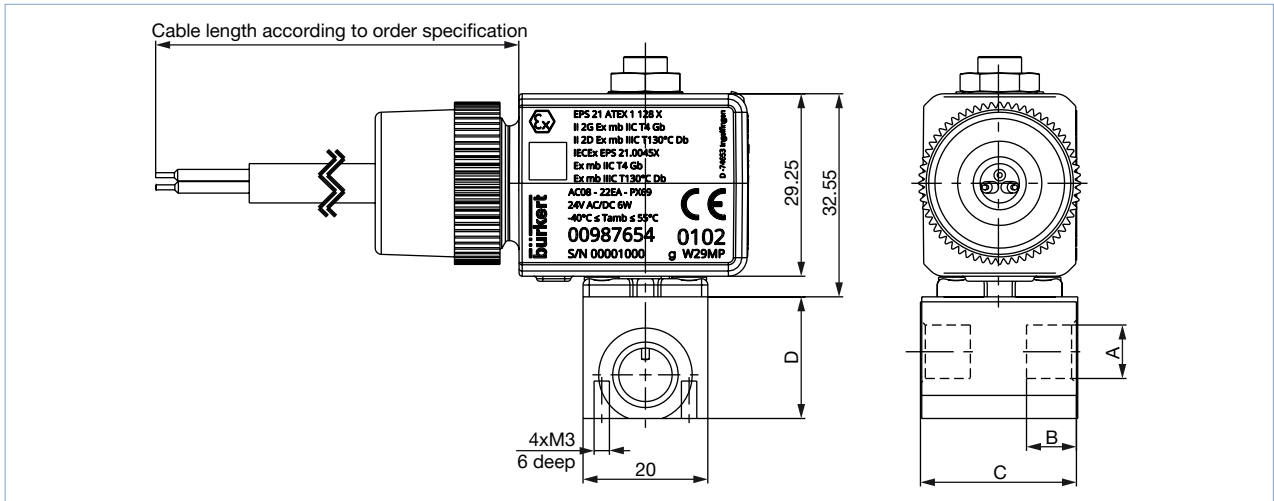

Port connection	A	B	C	D
Thread	M5	5	20	14
Thread	G 1/8	8	25	19.5

Flange version

Note:

Dimensions in mm

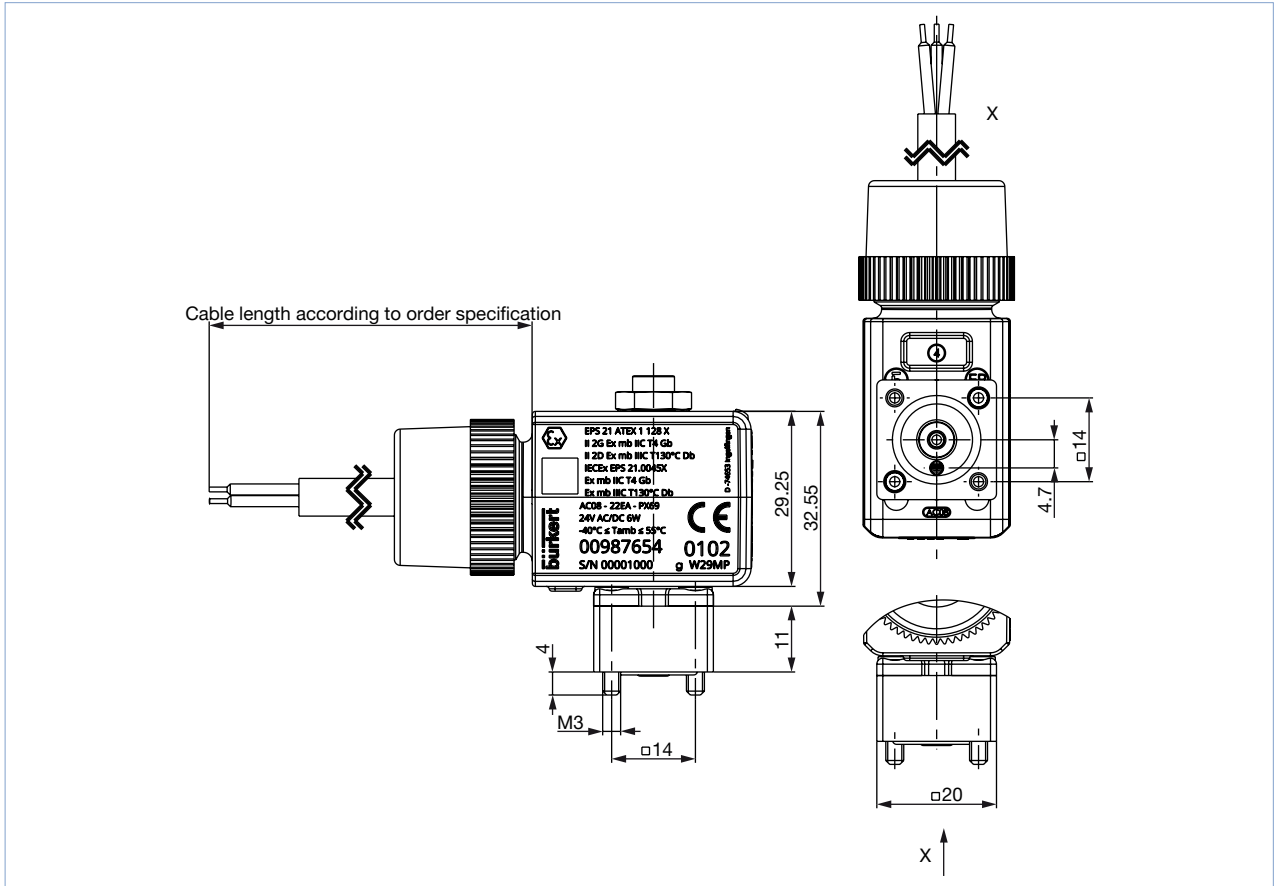

PIN Assignments

For the positions marked with *, ** or *** in the drawing, the connections are marked with the letters shown in the table above, depending on the circuit function. Unused connections in circuit functions A or B will be closed off with a blanking plug or cap nut.

Circuit function	Connection Type			Threaded version	Flange version
	*	**	***		
A	P	to lock	A		
B	to lock	B	P		
C	P	R	A		
D	R	P	B		
T	P	R	A		

Versions according to industry standard form B

Note:

Dimensions in mm

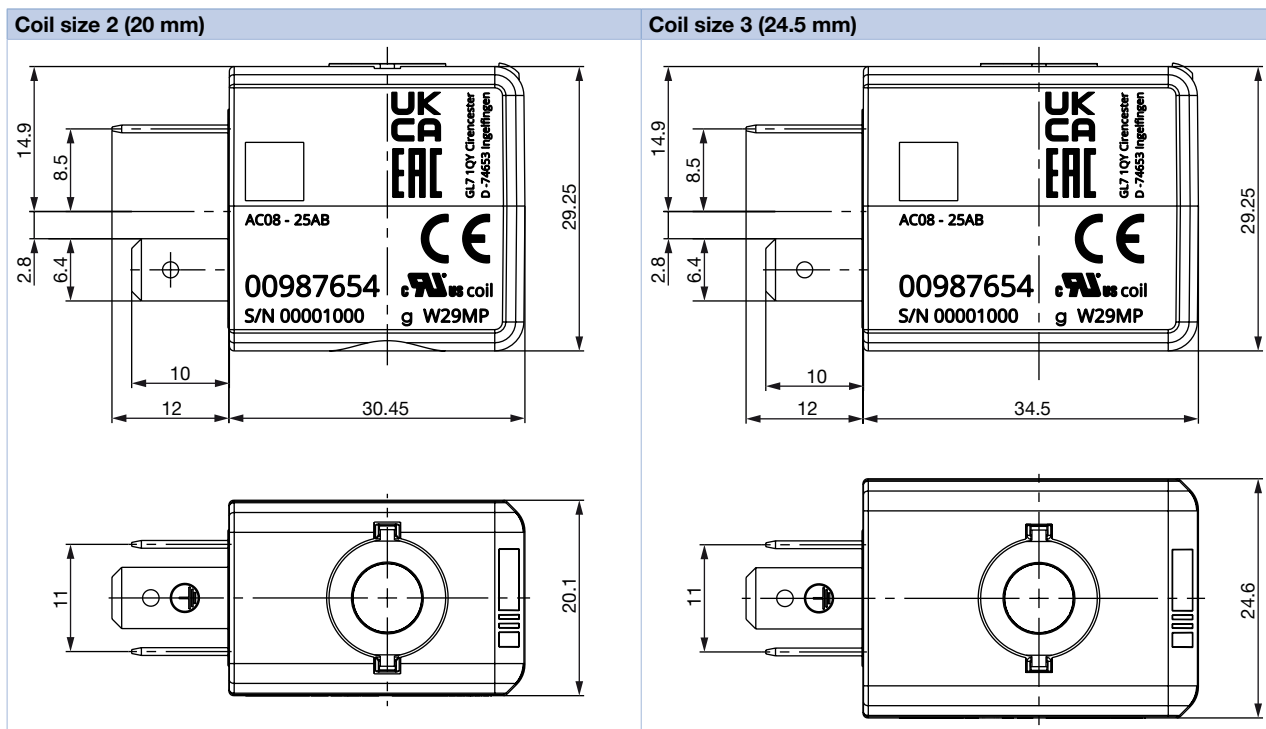

Further electrical connections

Note:

- Specifications apply to coil sizes 20 mm and 24.5 mm
- Dimensions in mm

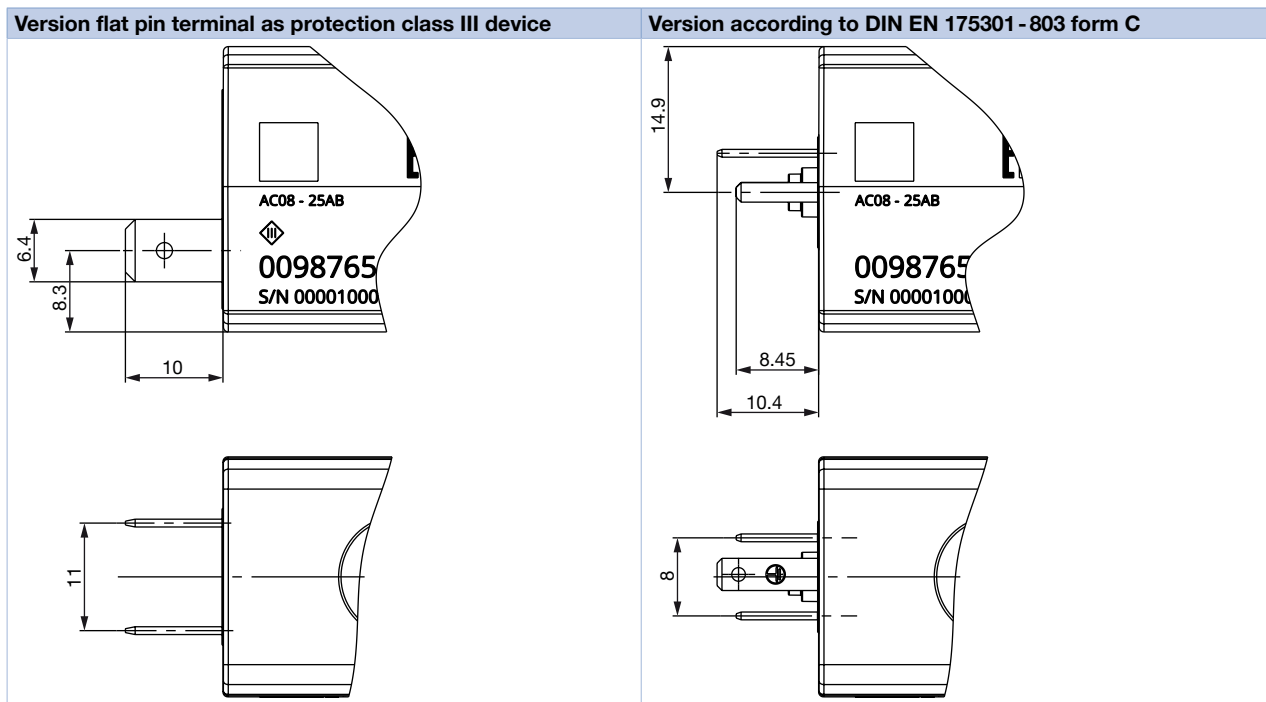

DTS 1000446517 EN Version: F Status: RL (released | freigegeben | valide) printed: 15.09.2022

5.3. Banjo version

Versions according to industry standard form B, coil size 24.5 mm

Note:

- Dimensions in mm
- Plug connection for compressed air: Pressure port P can be continuously rotated through 360°.
- Available orifices: 1.2 mm

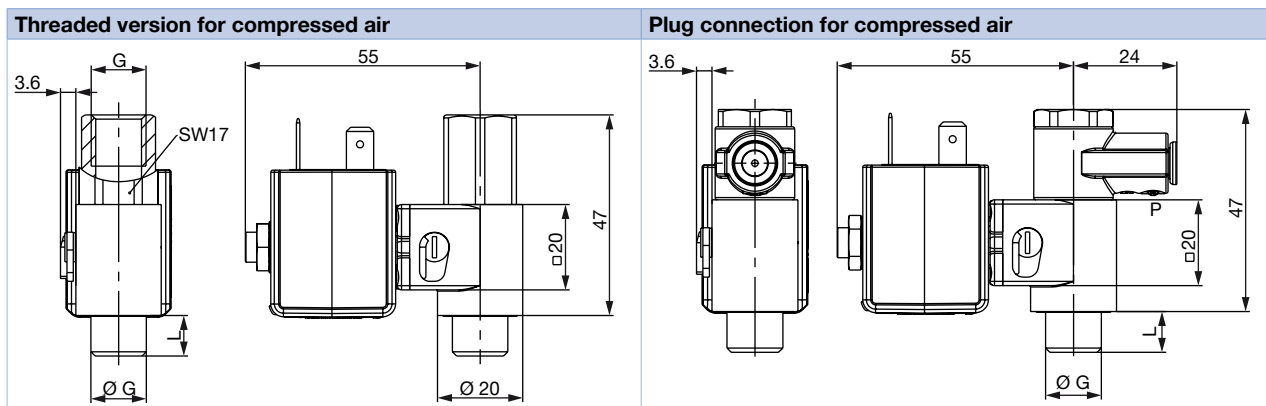

G	L
G 1/8	6.5
G 1/4	9.5

5.4. Multiple manifold

Note:

- Dimensions in mm
- Can only be combined with versions circuit function C (normally closed) and valves with coil size 20 mm
- Manifolds with valves of coil size 24.5 mm on request

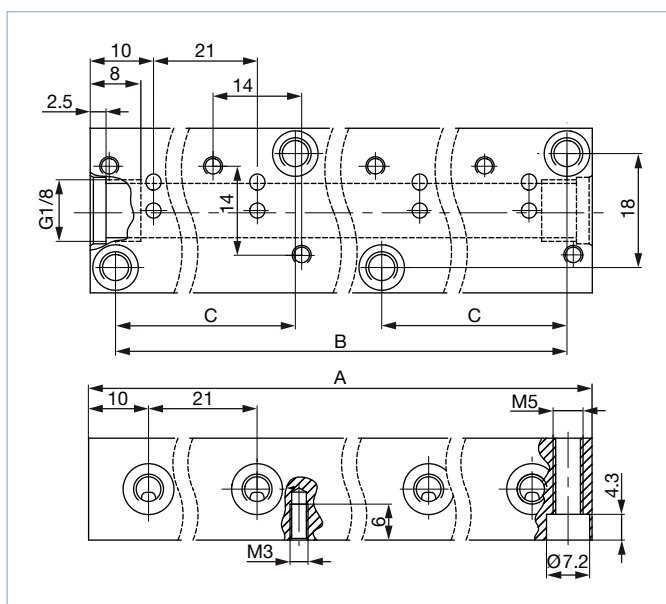

Quantity of valve places	A	B	C	Article no.
	[mm]	[mm]	[mm]	
1	20	12	–	005312
2	41	33	–	005355
3	62	54	–	005313
4	83	75	–	005314
5	104	96	–	005315
6	125	117	–	005316
7	146	138	–	005893
8	167	159	54	005166
9	188	180	54	005241
10	209	201	75	005819
11	230	222	75	005242
12	251	243	96	005222

DTS 1000446517 EN Version: F Status: RL (released | freigegeben | valide) printed: 15.09.2022

6. Performance specifications

6.1. Power consumption of standard coil version 24.5 mm

Coil	Orifice	Electrical power					Switching times ¹⁾	
		Inrush AC	Hold AC		DC		Opening	Closing
	[mm]	[VA]	[VA]	[W]	Cold [W]	Hot [W]	[ms]	[ms]
24 V / DC / 7 W	1.2	–	–	–	7	5.5	8...12	8...12
	1.6							
	2.0							
24 V / DC / 5.5 W	1.2	–	–	–	5.5	4.5		
	1.6							
	2.0							
24 V / 50 Hz / 4 W	1.2	12	6.5	4	–	–		
	1.6							
	2.0							
230 V / 50 Hz / 4 W	1.2	12	6.5	4	–	–		
	1.6							
	2.0							

1.) Measured at valve outlet at 6 bar²⁾ and +20 °C according to ISO 12238, opening: pressure rise 0...10%, closing: pressure drop 100...90%

2.) Measured as overpressure to the atmospheric pressure and air as a medium

6.2. Power consumption of standard coil version 20 mm

Coil	Orifice	Electrical power					Switching times ¹⁾	
		Inrush AC	Hold AC		DC		Opening	Closing
	[mm]	[VA]	[VA]	[W]	Cold [W]	Hot [W]	[ms]	[ms]
24 V / DC / 6.5 W	1.2	–	–	–	6.5	5	8...12	8...12
	1.6							
	2.0							
24 V / 50 Hz / 6 W	1.2	11	7	6	–	–		
	1.6							
	2.0							
230 V / 50 Hz / 6 W	1.2	11	7	6	–	–		
	1.6							
	2.0							
24 V / DC / 5 W	1.2	–	–	–	5	4		
	1.6							
	2.0							
24 V / 50 Hz / 4 W	1.2	9	5	4	–	–		
	1.6							
	2.0							
230 V / 50 Hz / 4 W	1.2	9	5	4	–	–		
	1.6							
	2.0							

1.) Measured at valve outlet at 6 bar²⁾ and +20 °C according to ISO 12238, opening: pressure rise 0...10%, closing: pressure drop 100...90%

2.) Measured as overpressure to the atmospheric pressure and air as a medium

7. Ordering information

7.1. Bürkert eShop – Easy ordering and quick delivery



Bürkert eShop – Easy ordering and fast delivery

You want to find your desired Bürkert product or spare part quickly and order directly? Our online shop is available for you 24/7. Sign up and enjoy all the benefits.

[Order online now](#)

7.2. Bürkert product filter

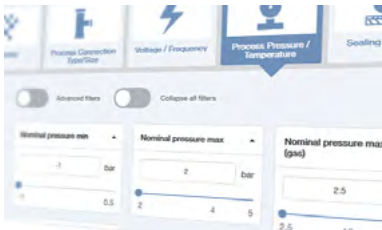

Bürkert product filter – Get quickly to the right product

You want to select products comfortably based on your technical requirements? Use the Bürkert product filter and find suitable articles for your application quickly and easily.

[Try out our product filter](#)

7.3. Ordering chart

Standard version according to industry standard form B, coil size 24.5 mm

Note:

All valves without cable plug

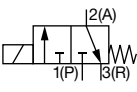
Circuit function	Port connection	Orifice	K _v value H ₂ O ^{1.)}	Voltage/ Frequency/ Power	Maximum duty cycle	Medium pressure [bar] ^{2.) 3.)}		Article no. Body material Brass	Article no. Body material stainless steel
						Ambient temperature 75 °C	Ambient temperature 55 °C		
		[mm]	[m ³ /h]	[V/Hz/W]	Air + water	Air + water	FKM seal		
C, solenoid valve 3/2 way Direct-acting Normally closed 	M5	1.2	0.045	24 V / DC / 7 W	100 % ED	–	0...13	380922	381000
				24 V / DC / 5.5 W		0...11.5	0...11.5	390256	390258
				24 V / 50 Hz / 4 W		0...13	0...13	380924	381002
				230 V / 50 Hz / 4 W		0...13	0...13	380927	381004
		1.6	0.06	24 V / DC / 7 W	100 % ED	–	0...7.5	380932	381021
				24 V / DC / 5.5 W		0...6	0...6	390265	390267
				24 V / 50 Hz / 4 W		0...7.5	0...7.5	380931	381023
				230 V / 50 Hz / 4 W		0...7.5	0...7.5	380928	381025
		2.0 ^{4.)}	0.11	24 V / DC / 7 W	100 % ED	–	0...7	X	X
				24 V / DC / 5.5 W		0...5	0...5	X	X
				24 V / 50 Hz / 4 W		0...6	0...6	X	X
				230 V / 50 Hz / 4 W		0...6	0...6	X	X
G 1/8	1.2	0.045	100 % ED	24 V / DC / 7 W	–	0...13	379906	380132	
				24 V / DC / 5.5 W	0...11.5	0...11.5	390269	390271	
				24 V / 50 Hz / 4 W	0...13	0...13	379928	380139	
				230 V / 50 Hz / 4 W	0...13	0...13	380116	380217	
	1.6	0.06	100 % ED	24 V / DC / 7 W	–	0...7.5	379915	380137	
				24 V / DC / 5.5 W	0...6	0...6	390275	390273	
				24 V / 50 Hz / 4 W	0...7.5	0...7.5	379930	380141	
				230 V / 50 Hz / 4 W	0...7.5	0...7.5	380118	380218	

DTS 1000446517 EN Version: F Status: RL (released | freigegeben | valide) printed: 15.09.2022

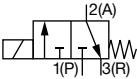
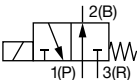
Circuit function	Port connection	Orifice	K _v value H ₂ O ^{1.)}	Voltage/ Frequency/ Power	Maximum duty cycle	Medium pressure [bar] ^{2.) 3.)}		Article no. Body material Brass	Article no. Body material stainless steel	
						Ambient temperature 75 °C	Ambient temperature 55 °C			
		[mm]	[m ³ /h]	[V/Hz/W]		Air + water	Air + water	FKM seal		
C, solenoid valve 3/2 way Direct-acting Normally closed 	G 1/8	2.0 ^{4.)}	0.11	24 V / DC / 7 W	100 % ED	–	0...7	X	X	
				24 V / DC / 5.5 W		0...5	0...5	X	X	
				24 V / 50 Hz / 4 W		0...6	0...6	X	X	
				230 V / 50 Hz / 4 W		0...6	0...6	X	X	
	Flange (FK01)	1.2	0.045	24 V / DC / 7 W	100 % ED	–	0...13	380943 𐀀	390301 𐀀	
				24 V / DC / 5.5 W		0...11.5	0...11.5	390348 𐀀	390351 𐀀	
				24 V / 50 Hz / 4 W		0...13	0...13	380942 𐀀	381029 𐀀	
				230 V / 50 Hz / 4 W		0...13	0...13	380940 𐀀	390353 𐀀	
		1.6	0.06	24 V / DC / 7 W	100 % ED	–	0...7.5	380934 𐀀	390355 𐀀	
				24 V / DC / 5.5 W		0...6	0...6	390358 𐀀	390360 𐀀	
				24 V / 50 Hz / 4 W		0...7.5	0...7.5	380936 𐀀	390362 𐀀	
				230 V / 50 Hz / 4 W		0...7.5	0...7.5	380938 𐀀	389484 𐀀	
	2.0 ^{4.)}	0.11	24 V / DC / 7 W	100 % ED	–	0...7	X	X		
			24 V / DC / 5.5 W		0...5	0...5	X	X		
			24 V / 50 Hz / 4 W		0...6	0...6	X	X		
			230 V / 50 Hz / 4 W		0...6	0...6	X	X		
D, solenoid valve 3/2 way Direct-acting Normally open 	M5	1.2	0.045	24 V / DC / 5.5 W	100 % ED	0...10	0...10	390363 𐀀	390365 𐀀	
				24 V / 50 Hz / 4 W		0...10	0...10	390367 𐀀	390382 𐀀	
				230 V / 50 Hz / 4 W		0...10	0...10	390385 𐀀	390384 𐀀	
		1.6	0.06	24 V / DC / 5.5 W	100 % ED	0...6	0...6	390390 𐀀	390392 𐀀	
				24 V / 50 Hz / 4 W		0...6	0...6	390396 𐀀	390398 𐀀	
				230 V / 50 Hz / 4 W		0...6	0...6	390400 𐀀	390401 𐀀	
		2.0 ^{4.)}	0.11	24 V / DC / 5.5 W	100 % ED	0...8	0...8	X	X	
				24 V / 50 Hz / 4 W		0...7	0...7	X ^{5.)}	X ^{5.)}	
				230 V / 50 Hz / 4 W		0...7	0...7	X ^{5.)}	X ^{5.)}	
		G 1/8	1.2	0.045	24 V / DC / 5.5 W	100 % ED	0...10	0...10	385475 𐀀	390402 𐀀
					24 V / 50 Hz / 4 W		0...10	0...10	390406 𐀀	390409 𐀀
					230 V / 50 Hz / 4 W		0...10	0...10	390438 𐀀	390439 𐀀
	1.6		0.06	24 V / DC / 5.5 W	100 % ED	0...6	0...6	390440 𐀀	390442 𐀀	
				24 V / 50 Hz / 4 W		0...6	0...6	390444 𐀀	390446 𐀀	
				230 V / 50 Hz / 4 W		0...6	0...6	390448 𐀀	390449 𐀀	
	2.0 ^{4.)}		0.11	24 V / DC / 5.5 W	100 % ED	0...8	0...8	X	X	
				24 V / 50 Hz / 4 W		0...7	0...7	X ^{5.)}	X ^{5.)}	
				230 V / 50 Hz / 4 W		0...7	0...7	X ^{5.)}	X ^{5.)}	
	Flange (FK01)		1.2	0.045	24 V / DC / 5.5 W	100 % ED	0...10	0...10	390450 𐀀	390452 𐀀
					24 V / 50 Hz / 4 W		0...10	0...10	390456 𐀀	390385 𐀀
					230 V / 50 Hz / 4 W		0...10	0...10	390459 𐀀	390460 𐀀
		1.6	0.06	24 V / DC / 5.5 W	100 % ED	0...6	0...6	390462 𐀀	390464 𐀀	
				24 V / 50 Hz / 4 W		0...6	0...6	390468 𐀀	390466 𐀀	
				230 V / 50 Hz / 4 W		0...6	0...6	390470 𐀀	390471 𐀀	
2.0 ^{4.)}		0.11	24 V / DC / 5.5 W	100 % ED	0...8	0...8	X	X		
			24 V / 50 Hz / 4 W		0...7	0...7	X ^{5.)}	X ^{5.)}		
			230 V / 50 Hz / 4 W		0...7	0...7	X ^{5.)}	X ^{5.)}		

X: on request

1.) Flow value for water, measured at +20 °C, 1 bar^{2.)} pressure at valve inlet and free outlet

2.) Measured as overpressure to the atmospheric pressure and air as a medium

3.) Number of switching cycles under laboratory conditions (FKM seal, oiled air, unpressurised, DC): 5 million. Please note that an increase in switching pressure can limit the life of the seat seal.

4.) Limited swelling compensation

5.) Can also be feasible with coil size 2

DTS 1000446517 EN Version: F Status: RL (released | freigegeben | valide) printed: 15.09.2022

Standard version according to industry standard form B, coil size 20 mm

Note:

All valves without cable plug

Circuit function	Port connection	Orifice	K _v value H ₂ O ¹⁾	Voltage/ Frequency/ Power	Maximum duty cycle	Medium pressure [bar] ^{2) 3)}		Article no. Body material Brass	Article no. Body material stainless steel
						Ambient temperature 75 °C	Ambient temperature 55 °C		
		[mm]	[m ³ /h]	[V/Hz/W]		Air + water	Air + water	FKM seal	
C, solenoid valve 3/2 way Direct-acting Normally closed 	M5	1.2	0.045	24 V / DC / 6.5 W	100 % ED	–	0...11	X	X
				24 V / 50 Hz / 6 W		–	0...13	X	X
				230 V / 50 Hz / 6 W		–	0...13	X	X
				24 V / DC / 5 W		0...10	0...10	X	X
				24 V / 50 Hz / 4 W		0...11	0...11	X	X
				230 V / 50 Hz / 4 W		0...11	0...11	X	X
		1.6	0.06	24 V / DC / 6.5 W	100 % ED	–	0...6	X	X
				24 V / 50 Hz / 6 W		–	0...7.5	X	X
				230 V / 50 Hz / 6 W		–	0...7.5	X	X
				24 V / DC / 5 W		0...5.5	0...5.5	X	X
				24 V / 50 Hz / 4 W		0...6	0...6	X	X
				230 V / 50 Hz / 4 W		0...6	0...6	X	X
		2.0 ⁴⁾	0.11	24 V / DC / 6.5 W	100 % ED	–	0...5	X	X
				24 V / 50 Hz / 6 W		–	0...6	X	X
				230 V / 50 Hz / 6 W		–	0...6	X	X
				24 V / DC / 5 W		0...4	0...4	X	X
				24 V / 50 Hz / 4 W		0...5.5	0...5.5	X	X
				230 V / 50 Hz / 4 W		0...5.5	0...5.5	X	X
	G 1/8	1.2	0.045	100 % ED	24 V / DC / 6.5 W	–	0...11	X	X
					24 V / 50 Hz / 6 W	–	0...13	X	X
					230 V / 50 Hz / 6 W	–	0...13	X	X
					24 V / DC / 5 W	0...10	0...10	X	X
					24 V / 50 Hz / 4 W	0...11	0...11	X	X
					230 V / 50 Hz / 4 W	0...11	0...11	X	X
		1.6	0.06	100 % ED	24 V / DC / 6.5 W	–	0...6	X	X
					24 V / 50 Hz / 6 W	–	0...7.5	X	X
					230 V / 50 Hz / 6 W	–	0...7.5	X	X
24 V / DC / 5 W					0...5.5	0...5.5	X	X	
24 V / 50 Hz / 4 W					0...6	0...6	X	X	
230 V / 50 Hz / 4 W					0...6	0...6	X	X	
2.0 ⁴⁾		0.11	100 % ED	24 V / DC / 6.5 W	–	0...5	X	X	
				24 V / 50 Hz / 6 W	–	0...6	X	X	
				230 V / 50 Hz / 6 W	–	0...6	X	X	
				24 V / DC / 5 W	0...4	0...4	X	X	
				24 V / 50 Hz / 4 W	0...5.5	0...5.5	X	X	
				230 V / 50 Hz / 4 W	0...5.5	0...5.5	X	X	
Flange (FK01)	1.2	0.045	100 % ED	24 V / DC / 6.5 W	–	0...11	X	X	
				24 V / 50 Hz / 6 W	–	0...13	X	X	
				230 V / 50 Hz / 6 W	–	0...13	X	X	
				24 V / DC / 5 W	0...10	0...10	X	X	
				24 V / 50 Hz / 4 W	0...11	0...11	X	X	
				230 V / 50 Hz / 4 W	0...11	0...11	X	X	

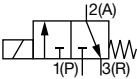
Circuit function	Port connection	Orifice		Voltage/ Frequency/ Power	Maximum duty cycle	Medium pressure [bar] ²⁾³⁾		Article no. Body material Brass	Article no. Body material stainless steel					
		[mm]	K _v value H ₂ O ¹⁾ [m ³ /h]			Ambient temperature 75 °C	Ambient temperature 55 °C							
						Air + water	Air + water			FKM seal				
C, solenoid valve 3/2 way Direct-acting Normally closed 	Flange (FK01)	1.6	0.06	24 V / DC / 6.5 W	100 % ED	–	0...6	X	X					
				24 V / 50 Hz / 6 W		–	0...7.5	X	X					
				230 V / 50 Hz / 6 W		–	0...7.5	X	X					
				24 V / DC / 5 W		0...5.5	0...5.5	X	X					
				24 V / 50 Hz / 4 W		0...6	0...6	X	X					
				230 V / 50 Hz / 4 W		0...6	0...6	X	X					
		2.0 ⁴⁾	0.11	24 V / DC / 6.5 W	100 % ED	–	0...5	X	X					
				24 V / 50 Hz / 6 W		–	0...6	X	X					
				230 V / 50 Hz / 6 W		–	0...6	X	X					
				24 V / DC / 5 W		0...4	0...4	X	X					
				24 V / 50 Hz / 4 W		0...5.5	0...5.5	X	X					
				230 V / 50 Hz / 4 W		0...5.5	0...5.5	X	X					
				D, solenoid valve		M5	1.2	0.045	24 V / DC / 5 W	100 % ED	0...10	0...10	X	X
									24 V / 50 Hz / 4 W		0...10	0...10	X	X
230 V / 50 Hz / 4 W	0...10	0...10	X		X									
1.6	0.06	24 V / DC / 5 W	100 % ED		0...6		0...6	X	X					
		24 V / 50 Hz / 4 W			0...6		0...6	X	X					
		230 V / 50 Hz / 4 W			0...6		0...6	X	X					
2.0 ⁴⁾	0.11	24 V / DC / 6.5 W	100 % ED	–	0...8	X	X							
		24 V / DC / 5 W		0...6	0...6	X	X							
		24 V / 50 Hz / 4 W		0...7	0...7	X	X							
		230 V / 50 Hz / 4 W		0...7	0...7	X	X							
		G 1/8		1.2	0.045	24 V / DC / 5 W	100 % ED	0...10	0...10	X	X			
						24 V / 50 Hz / 4 W		0...10	0...10	X	X			
230 V / 50 Hz / 4 W	0...10		0...10			X		X						
1.6	0.06		24 V / DC / 5 W	100 % ED	0...6	0...6	X	X						
			24 V / 50 Hz / 4 W		0...6	0...6	X	X						
			230 V / 50 Hz / 4 W		0...6	0...6	X	X						
2.0 ⁴⁾	0.11	24 V / DC / 6.5 W	100 % ED	–	0...8	X	X							
		24 V / DC / 5 W		0...6	0...6	X	X							
		24 V / 50 Hz / 4 W		0...7	0...7	X	X							
		230 V / 50 Hz / 4 W		0...7	0...7	X	X							
		Flange (FK01)		1.2	0.045	24 V / DC / 5 W	100 % ED	0...10	0...10	X	X			
						24 V / DC / 5.5 W		0...6	0...6	X	X			
24 V / 50 Hz / 4 W	0...10		0...10			X		X						
230 V / 50 Hz / 4 W	0...10		0...10			X		X						
1.6	0.06		24 V / DC / 5 W	100 % ED	0...6	0...6	X	X						
			24 V / 50 Hz / 4 W		0...6	0...6	X	X						
			230 V / 50 Hz / 4 W		0...6	0...6	X	X						
2.0 ⁴⁾	0.11		24 V / DC / 6.5 W	100 % ED	–	0...8	X	X						
			24 V / DC / 5 W		0...6	0...6	X	X						
24 V / 50 Hz / 4 W	0...7	0...7	X	X										
					230 V / 50 Hz / 4 W	0...7	0...7	X	X					

X: on request

1.) Flow value for water, measured at +20 °C, 1 bar²⁾ pressure at valve inlet and free outlet

2.) Measured as overpressure to the atmospheric pressure and air as a medium

3.) Number of switching cycles under laboratory conditions (FKM seal, oiled air, unpressurised, DC): 5 million. Please note that an increase in switching pressure can limit the life of the seat seal.











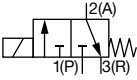





















4.) Limited swelling compensation

DTS 1000446517 EN Version: F Status: RL (released | freigegeben | valide) printed: 15.09.2022

Banjo version, coil size 24.5 mm

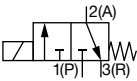
Note:

All valves without cable plug

Circuit function	Port connection	Orifice	Q _{Nn} value air	Voltage/Frequency/ Power	Maximum duty cycle	Medium pressure [bar] ^{1,2)}	Article no.
		[mm]	[l/min]	[V/Hz/W]		Ambient temperature +40 °C	
C, solenoid valve 3/2 way Direct-acting Normally closed 	BJ01 P: G 1/8 A: G 1/8	1.2	48	24 V / DC / 7 W	100 % ED	0...13	390839 
				24 V / DC / 5.5 W		0...11.5	390842 
				24 V / 50 Hz / 4 W		0...13	390845 
				230 V / 50 Hz / 4 W		0...13	390847 
	BJ02 P: G 1/4 A: G 1/4	1.2	48	24 V / DC / 7 W	100 % ED	0...13	390848 
				24 V / DC / 5.5 W		0...11.5	390850 
				24 V / 50 Hz / 4 W		0...13	390852 
				230 V / 50 Hz / 4 W		0...13	390854 
	BJ03 P: NPT 1/4 A: G 1/8	1.2	48	24 V / DC / 7 W	100 % ED	0...13	390855 
				24 V / DC / 5.5 W		0...11.5	390858 
				24 V / 50 Hz / 4 W		0...13	390860 
				230 V / 50 Hz / 4 W		0...13	390862 
	BJ05 P: G 1/4 A: G 1/8	1.2	48	24 V / DC / 7 W	100 % ED	0...13	384300 
				24 V / DC / 5.5 W		0...11.5	390831 
24 V / 50 Hz / 4 W				0...13		390832 	
230 V / 50 Hz / 4 W				0...13		390835 	
BJ07 P: NPT 1/8 A: G 1/8	1.2	48	24 V / DC / 7 W	100 % ED	0...13	390864 	
			24 V / DC / 5.5 W		0...11.5	390867 	
			24 V / 50 Hz / 4 W		0...13	390869 	
			230 V / 50 Hz / 4 W		0...13	390871 	
BJ08 P: Hose connection 6 mm A: G 1/8	1.2	48	24 V / DC / 7 W	100 % ED	0...13	390875 	
			24 V / DC / 5.5 W		0...11.5	390880 	
			24 V / 50 Hz / 4 W		0...13	390884 	
			230 V / 50 Hz / 4 W		0...13	390887 	
BJ09 P: Hose connection 6 mm A: G 1/4	1.2	48	24 V / DC / 7 W	100 % ED	0...13	390894 	
			24 V / DC / 5.5 W		0...11.5	390905 	
			24 V / 50 Hz / 4 W		0...13	390909 	
			230 V / 50 Hz / 4 W		0...13	390911 	
C, solenoid valve 3/2 way Direct-acting Normally closed 	BJ10 P: NPT 1/4 A: G 1/4	1.2	48	24 V / DC / 7 W	100 % ED	0...13	390916 
				24 V / DC / 5.5 W		0...11.5	390918 
				24 V / 50 Hz / 4 W		0...13	390922 
				230 V / 50 Hz / 4 W		0...13	390924 







1.) Measured as overpressure to the atmospheric pressure and air as a medium

2.) Number of switching cycles under laboratory conditions (FKM seal, oiled air, unpressurised, DC): 5 million. Please note that an increase in switching pressure can limit the life of the seat seal.

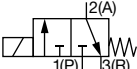
ATEX/IECEx version

Note:

- The maximum media temperature must not exceed the permissible temperature class (T4 135 °C) minus 5 K under any circumstances.
- Only single mounting permissible
- With 3 m cable as standard. Other lengths on request.

Circuit function	Port connection	Orifice	K _v value H ₂ O ^{1.)}	Voltage/Frequency/ Power	Maximum duty cycle	Medium pressure [bar] ^{2.)}	Article no. Body material Brass	Article no. Body material stainless steel
						Ambient temperature +55 °C		
		[mm]	[m ³ /h]	[V/Hz/W]		Air + water	FKM seal	
C, solenoid valve 3/2 way Direct-acting Normally closed 	G 1/6	1.2	0.045	24 V / AC/DC / 6 W	100 % ED	0...11	20017950 	X
				230 V / AC/DC / 6 W		0...11	20017953 	X
		1.6	0.06	24 V / AC/DC / 6 W	100 % ED	0...7	20017954 	X
				230 V / AC/DC / 6 W		0...7	20017958 	X
		2.0	0.11	24 V / AC/DC / 6 W	100 % ED	0...5	20017961 	X
				230 V / AC/DC / 6 W		0...5	20010156 	X

X: on request

1.) Flow value for water, measured at +20 °C, 1 bar^{2.)} pressure at valve inlet and free outlet

2.) Measured as overpressure to the atmospheric pressure and air as a medium

Additional options

Note:

Available on request

Option	Variable Code	Description
Oxygen versions	NL02	Suitable for applications with oxygen (non-metal materials that are in contact with the medium are tested and approved according to BAM)
Increased purity requirements e.g. oil, grease and silicone-free	NL50/NL05	Wetted parts are specially cleaned and packaged in accordance with the valves
Increased tightness requirements	PC05	Leakage rate *less than 10 ⁻⁴ mbar l/sec
	PC08	Leakage rate *less than 10 ⁻⁵ mbar l/sec
	PC06	Leakage rate *less than 10 ⁻⁶ mbar l/sec
Vacuum version	on request	–

7.4. Ordering chart accessories

Multiple manifolds

Note:

Detailed order information can be found in chapter [“5.4. Multiple manifold”](#) on page 12.

Accessories for manifolds

Accessory	Features	Article no.
Screw plug	With sealing ring, G 1/8	005041
Cover plate	For unoccupied valve position	005100

Cable plug Type 2516, form C according to DIN EN 175301 - 803

Note:

- Delivery of cable plug includes a flat seal and a fixing screw.
- Further versions of cable plug with circuitry acc. to DIN EN 175 301 -803 form C as well as detailed technical data, see data sheet [Type 2516](#) ▶.

Cable plug	Version	Voltage	Article no.
	Without circuitry (standard)	0...250 V AC/DC	303141
	With LED	12...24 V AC/DC	303145
	With LED and varistor	12...24 V AC/DC	303148
	With rectifier, LED and varistor	12...24 V AC/DC	303142

Cable plug Type 2507, form B according to industry standard

Note:

- Delivery of cable plug includes a flat seal and a fixing screw.
- Further versions of cable plug with circuitry acc. to industry standard connector form B as well as detailed technical data, see data sheet [Type 2507](#) ▶.

Cable plug	Version	Voltage	Article no.
	Without circuitry (standard)	2...250 V AC/DC	423845
	With LED	24 V AC/DC	423849
	With LED and free-wheeling diode	12...24 V AC/DC	423851
	With rectifier, LED and varistor	12...24 V AC/DC	423853

Bürkert – Close to You

For up-to-date addresses
please visit us at
www.burkert.com

DTS 1000446517 EN Version: F Status: RL (released | freigegeben | validé) printed: 15.09.2022

