

EPS 16 ATEX 1072 X, IECEx EPS 16.0030X

Solenoid coil Type AC19

Magnetspule Typ AC19

Bobine magnétique Type AC19

Device with II 2G/D Ex approval

Geräte mit II 2G/D Ex Zulassung

Appareils avec mode de protection II 2G/D Ex



Operating Instructions

Bedienungsanleitung

Manuel d'utilisation



We reserve the right to make technical changes without notice.
Technische Änderungen vorbehalten.
Sous réserve de modifications techniques.

© Bürkert Werke GmbH & Co KG, 2020-2022

Operating Instructions 2212/03_EU-ML_00815342 / Original DE

1 OPERATING INSTRUCTIONS	4	7.6 Types of protection.....	13
1.1 Definition of terms/abbreviations	4	7.7 Electrical data.....	14
1.2 Symbols.....	4	8 ACCESSORIES	15
2 INTENDED USE	5	8.1 Cable gland for terminal boxes	15
2.1 Ex approval.....	5	8.2 External earth connection for terminal box	15
3 GENERAL SAFETY INSTRUCTIONS	6	9 INSTALLATION AND DISASSEMBLY	16
4 GENERAL NOTES	7	9.1 Installing the valve	16
4.1 Contact addresses	7	9.2 Electrical connection	17
4.2 Warranty	7	9.3 Disassembly	18
4.3 Information online.....	7	10 START-UP	19
5 PRODUCT DESCRIPTION	8	11 MAINTENANCE, REPAIRS, TROUBLESHOOTING	19
5.1 Structure.....	8	11.1 Maintenance.....	19
5.2 Solenoid with cable outlet.....	9	11.2 Repair	19
5.3 Solenoid with terminal box	9	11.3 Troubleshooting.....	19
6 DEVICE USAGE CONDITIONS	10	12 TRANSPORT, STORAGE, PACKAGING	20
6.1 Special conditions	10		
6.2 Operating conditions.....	10		
6.3 Operating temperature range	10		
7 TECHNICAL DATA	11		
7.1 Safety instructions.....	11		
7.2 Conformity.....	11		
7.3 Standards.....	11		
7.4 Labelling of solenoid with cable outlet.....	11		
7.5 Label of solenoid with terminal box.....	12		

1 OPERATING INSTRUCTIONS

The operating instructions describe the entire life cycle of the device. Keep these instructions in a location which is easily accessible to every user and make them available to every new owner of the device.

Important safety information!

- ▶ Carefully read these instructions.
- ▶ Observe in particular the safety instructions, intended use and operating conditions.
- ▶ Persons who work on the device must read and understand these instructions.

1.1 Definition of terms/abbreviations

The term 'device' used in these instructions always refers to the Type AC19 solenoid.



The abbreviation 'Ex' used in these instructions always stands for "potentially explosive atmosphere".

1.2 Symbols

The following symbols are used in these instructions.



DANGER!

Warns of an immediate danger.

- ▶ Failure to observe these instructions will result in death or serious injuries.



WARNING!

Warns of a potentially hazardous situation.

- ▶ Failure to observe these instructions may result in serious injuries or death.



CAUTION!

Warns of a potential danger.

- ▶ Failure to observe these instructions may result in moderate or minor injuries.

NOTE!

Warns of damage



Important tips and recommendations.



Refers to information in these operating instructions or in other documentation.

- ▶ Designates instructions to avoid a danger.

→ Highlights a procedure which you must carry out.

2 INTENDED USE

Improper use of the AC19 solenoid may be dangerous to people, nearby equipment and the environment.

The Type AC19 solenoid is used to operate valves that control gaseous or liquid media.

- ▶ A valve operated by the AC19 solenoid is to be used exclusively with the permissible media specified in the data sheet and for use in explosion group IIC, category 2G or explosion group IIIC, category 2D and temperature class T4 (see details on the type label for the Ex area).
- ▶ The solenoid may only be used for the applications specified in chapter “6 Device usage conditions” and in connection with the external devices and components recommended and permitted by Bürkert.
- ▶ The type of protection used is the Ex encapsulation ‘m’ for coils with cable connections.
- ▶ The type of protection for the optionally installed terminal boxes is ‘e’ for gas and ‘t’ for dust.
- ▶ Prerequisites for safe and trouble-free operation of the system are proper transport, storage and installation as well as careful operation and maintenance. Any other or additional use is not considered part of the **intended use**. Bürkert will not be liable for any damage resulting from this. The user alone bears the risk.
- ▶ Only use the device as intended.

2.1 Ex approval

The explosion protection approval is only valid if you use the modules and components authorised by Bürkert as described in these operating instructions.

The AC19 solenoid may be used only in combination with the additional components approved by Bürkert, otherwise the explosion protection approval is terminated. In the event of unauthorised changes to the device, modules or components, the explosion protection approval is also terminated.

This product is subject to review by the Shanghai Inspection and Testing Institute of Instruments and Automation Systems Co., Ltd. (SITIIAS), has been CCC certified to comply with requirements of national explosion-proof series standard (GB/T 3836.2021-Explosive Atmospheres).

The following EC type approval test certificate and IECEx certificates have been issued by:

Bureau Veritas
 Consumer Products
 Services Germany GmbH
 Businesspark A96
 86842 Türkheim, Germany

AC19 solenoid: EPS 16 ATEX 1072 X
 IECEx EPS 16.0030 X

Terminal box: PTB 15 ATEX 1011 U
 IECEx PTB 15.0037 U

Production will be audited by: CE 102PTB
 (Physikalisch Technische Bundesanstalt)
 Bundesallee 100
 38116 Braunschweig, Germany

You can find the EC type approval test certificate online at:

www.burkert.com

3 GENERAL SAFETY INSTRUCTIONS

These safety instructions do not take into account any unforeseen circumstances and events that occur during installation, operation and maintenance.

The operator is responsible for observing the location-specific safety regulations, also with reference to personnel.



Risk of injury due to high pressure in the system or device.

- ▶ Before working on the system or device, switch off the pressure and ventilate or empty the lines.

Risk of injury due to electric shock.

- ▶ Before working on the system or device, switch off the power supply and secure it against reactivation.
- ▶ Observe the applicable accident prevention and safety regulations for electrical devices.

Risk of burns or fire from hot device surfaces due to prolonged operation.

The solenoid can become very hot during continuous operation.

- ▶ Keep the device away from highly flammable substances and media and do not touch with bare hands.



Risk of explosion.

Solenoids and valve bodies form a closed system after installation. When used in a potentially explosive atmosphere, there is a risk of explosion when the system is opened in the operating state.

- ▶ Do not dismantle or open the system during operation.

Risk of explosion due to electrostatic discharge.

If there is a sudden discharge of electrostatically charged devices or persons, there is a risk of explosion in the Ex area.

- ▶ Use suitable measures to ensure that electrostatic charges cannot occur in the Ex area.
- ▶ The device must not be used in areas with processes that generate heavy charges, involve automated grinding or cutting, the spraying of electrons (e.g. near electrostatic painting equipment) or generate pneumatically propelled dust.
- ▶ Clean the device surface by gently wiping it with a damp or anti-static cloth only.

To avoid the risk of explosions, the following must be observed in the Ex area:

- ▶ Information about temperature class, ambient temperature, degree of protection and voltage on the type label for the Ex area.
- ▶ Installation, operation and maintenance may only be performed by qualified personnel.
- ▶ Observe applicable safety regulations (also national safety regulations) as well as the general rules for the technology during setup and operation.

- ▶ Repairs may be carried out by the manufacturer only.
- ▶ Do not subject the device to mechanical and/or thermal stresses which exceed the limits described in the operating instructions.
- ▶ The terminal box may only be opened when the power is off.

General hazardous situations.

To prevent injuries, ensure that you:

- ▶ Secure the device against unintentional activation.
- ▶ Note the flow direction when installing.
- ▶ Following an interruption in the power supply, ensure that the process is restarted in a controlled manner.
- ▶ Do not use the device as a lever when screwing the valve into the line.

4 GENERAL NOTES

4.1 Contact addresses

Germany

Bürkert Fluid Control Systems
Sales Centre
Christian-Bürkert-Str. 13-17
D-74653 Ingelfingen
Tel. + 49 (0) 7940 - 10 91 111
Fax + 49 (0) 7940 - 10 91 448
E-mail: info@burkert.com

International

The contact addresses can be found on the back pages of the printed operating instructions.

They are also available online at: www.burkert.com

4.2 Warranty

A precondition for the warranty is that the AC19 solenoid is used as intended in consideration of the specified application conditions.

4.3 Information online

Operating instructions and data sheets for Bürkert products can be found online at: www.burkert.com

5 PRODUCT DESCRIPTION

5.1 Structure

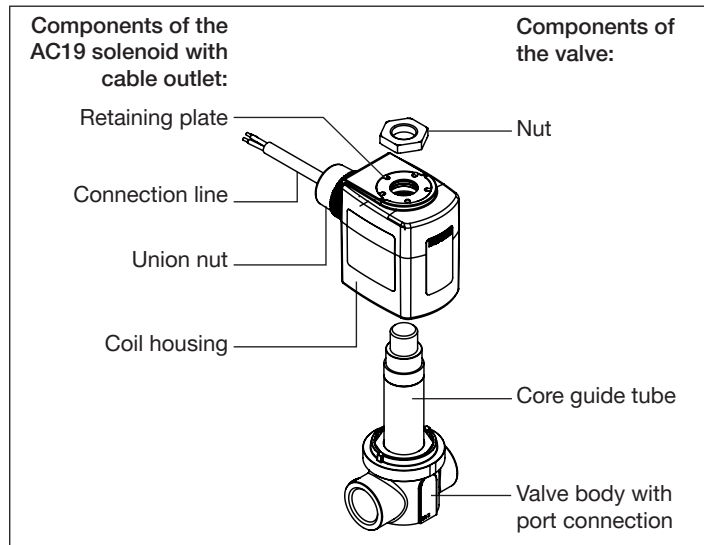

Fig. 1: Type AC19 solenoid with cable outlet

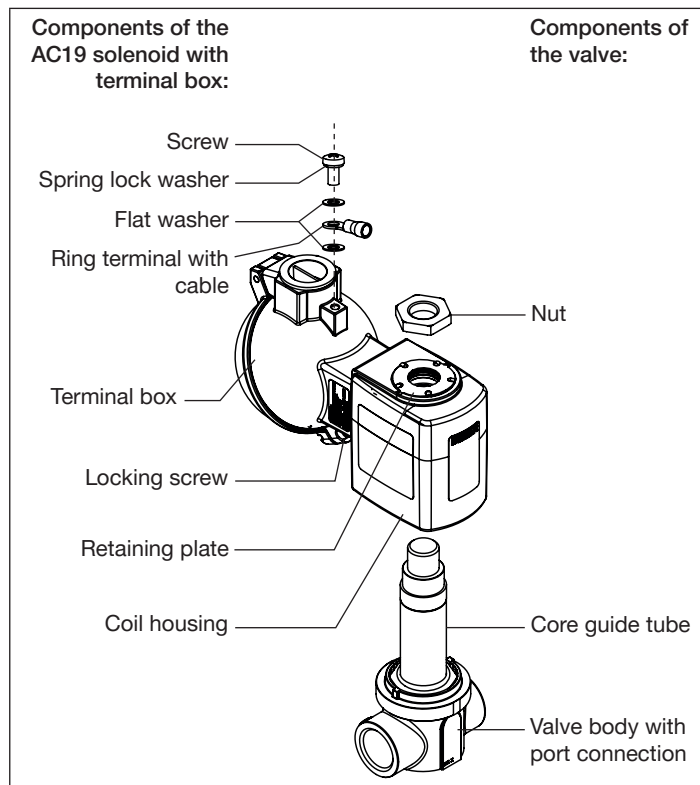

Fig. 2: Type AC19 solenoid with terminal box

5.2 Solenoid with cable outlet

The Type AC19 solenoid is an electromagnetic valve actuator for various Bürkert valves. As a so-called central screwed coil it is 100% separate from the valve. The valve itself is a closed system even when the coil is removed.

The solenoid consists of:

- coil winding,
- coil housing (made of epoxide),
- electrical connection cable,
- control electronics.

Actuation is possible with alternating or direct current due to the integrated bridge rectifier. A version with electronic power switching to reduce the power consumption in the operating state is optionally available.

The coil is placed over the core guide tube of the valve and fastened with a nut. It is positively secured against rotation toward the valve.

The outlet of the electrical connection line is perpendicular to the coil axis. The cable is firmly integrated into the coil. The union nut is not intended to be removed.

The metal valve components are brought into electrical contact with the coil at the interface between the coil and the valve. The metal components must be earthed via the protective conductor on the connection line.

5.3 Solenoid with terminal box

The solenoid setup is identical to the description under “[5.2](#)”, but here a terminal box is additionally built in (see “[Fig. 2](#)”). The terminal box is certified by EU type approval test certificate PTB 15 ATEX 1011 U or IECEx PTB 15.0037 U.

The cable outlet direction can be selected based on the ordering information. The cable outlet direction can be altered later, but a special tool is needed for that¹⁾. A connection set for additional potential equalisation is optionally included, see the information in chapter “[8.2](#)”.

1) *Get in touch with your assigned Bürkert contact person*

6 DEVICE USAGE CONDITIONS

6.1 Special conditions

6.1.1 Avoiding electrostatic charge



WARNING!

Hazard due to electrostatic discharge.

If there is a sudden discharge of electrostatically charged devices or persons, there is a risk of explosion in the Ex area.

- ▶ Use suitable measures to ensure that electrostatic charges cannot occur in the Ex area.
- ▶ The device must not be used in areas with processes that generate heavy charges, involve automated grinding or cutting, the spraying of electrons (e.g. near electrostatic painting equipment), or generate pneumatically propelled dust.
- ▶ Clean the device surface by gently wiping it with a **damp** or **anti-static** cloth only.

6.1.2 Block installation

The AC19 coil is fundamentally designed for single installation. With block installation, it is essential that the user ensures that the permitted ambient temperature is not exceeded due to reciprocal heating.

6.2 Operating conditions

The valve fulfils a cooling function for the solenoid.

The solenoid must not be operated without a valve. The valve body must meet the following prerequisites:

- Material
Metal (brass, aluminium, stainless steel) or polyamide
- Minimum dimensions
55 mm x 36 mm x 30 mm

A larger valve body with better thermal conductivity may be used at any time.

6.3 Operating temperature range

Pay attention to the operating temperature range for each type listed in the electrical data.

7 TECHNICAL DATA

7.1 Safety instructions



DANGER!

Risk of explosion.

If the technical safety information and values listed on the type label are not observed and complied with, dangerous situations could occur.

- ▶ Observe the degree of protection and temperature class for operating the device.

Exceeding the voltage stated on the type label is a technical safety risk that can cause the device to overheat.

- ▶ Do not connect the device to voltage higher than what is specified on the type label.

7.2 Conformity

The Type AC19 solenoid conforms to the EU Directives as per the EU Declaration of Conformity.

7.3 Standards

The applied standards used to verify compliance with the EU Directives can be found in the EU type examination certificate and/or the EU Declaration of Conformity.

7.4 Labelling of solenoid with cable outlet

AC19 solenoid with example valve and the position type labels:

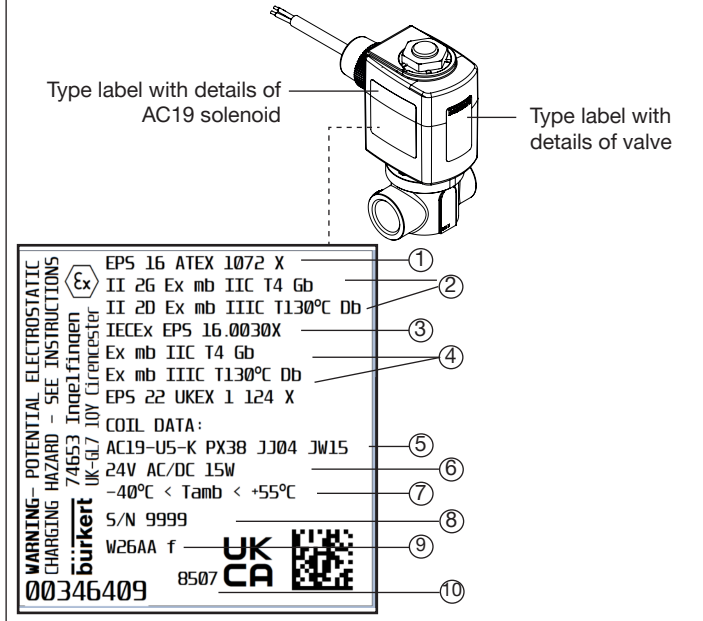

Fig. 3: Location and description of the Ex type label

Legend:

Position	Description
1	ATEX, certificate author and certificate number
2	ATEX, identification of the Ex protection
3	IECEX, certificate author and certificate number
4	IECEX, identification of the Ex protection
5	Type label with Ex code
6	Nominal voltage, nominal power
7	Ambient temperature range
8	Serial number
9	Date of manufacture
10	Identification number

7.5 Label of solenoid with terminal box

NOTE!

The type of protection changes when the terminal box is attached.

AC19 solenoid with terminal box with example valve and the type label positions:

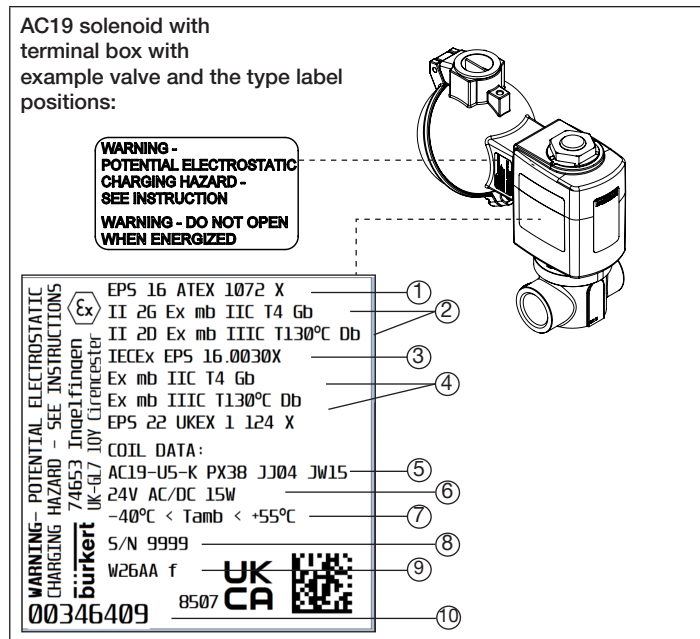

Fig. 4: Location and description of the Ex type labels

Legend:

Position	Description
1	ATEX, certificate author and certificate number
2	ATEX, identification of the Ex protection
3	IECEX, certificate author and certificate number
4	IECEX, identification of the Ex protection
5	Type label with Ex code
6	Nominal voltage, nominal power
7	Ambient temperature range
8	Serial number
9	Date of manufacture
10	Identification number

7.6 Types of protection

The Ex label indicates the types of protection of each component used.

	Variant	Ex labelling	Internal code
ATEX	Cable outlet	II 2G Ex mb IIC T4 Gb II 2D Ex mb IIIC T130 °C Db	JJ04 + JWxx ²⁾ + PX38
	Terminal box	II 2G Ex eb mb IIC T4 Gb II 2D Ex mb tb IIIC T130 °C Db	JA13 + PX38
IECEX	Cable outlet	Ex mb IIC T4 Gb Ex mb IIIC T130 °C Db	JJ04 + JWxx ²⁾ + PX38
	Terminal box	Ex eb mb IIC T4 Gb Ex mb tb IIIC T130 °C Db	JA13 + PX38

2) Varying cable lengths

7.7 Electrical data

Version	Bridge rectifier	Power switching
Internal code	CZ24	CZ05
Nominal voltage/frequency	24 V DC/50, 60 Hz 110 V DC/50, 60 Hz 120 V/60 Hz 230 V DC/50, 60 Hz 240 V/60 Hz	24 V DC/50, 60 Hz 110 V/50, 60 Hz 120 V/60 Hz 230 V/50, 60 Hz 240 V/60 Hz
Nominal power	15 W	44 W
Reduced nominal power	n/a	6.5 W
Ambient temperature range	-40...+55 °C	-40...+70 °C
Temperature class	T4/130 °C	
Max. switching frequency	n/a	30/min
Min. currentless break	n/a	1 s
Operating mode (according to DIN VDE 0580)	Continuous operation Intermittent operation Short-term operation	

7.7.1 Electrical connection

Technical data of the cable:

Material ³⁾ :	Polyolefin
Operating temperature range ³⁾ :	-55...+145 °C with fixed installation
Minimum bending radius ³⁾ :	4 x external diameter with fixed installation
External diameter ³⁾ :	6.2 mm
Setup/function:	3 x copper strands, 0.5 mm ² /LNPE

Halogen-free according to IEC 60754-1

Variants	Internal code
Permanently installed cable	JJ04 + JWxx ⁴⁾
Terminal box with internal thread M20 x 1.5	JA13

3) Details according to the manufacturer

4) Varying cable lengths

8 ACCESSORIES

8.1 Cable gland for terminal boxes

Suitable cable glands are available for use with the terminal box.



Plastic cable gland is included in the scope of delivery of the valve. Brass cable gland must be ordered separately. Cable glands from other manufacturers can also be used if the cable glands are designed for the location and correct installation. Please note that the operating temperature of the cable gland must be min. 15 K above the max. ambient temperature.

Material	Clamping area [mm]	Operating temperature	Order number	Certificate No.
Plastic	7–13	–40...+75 °C	773 277	5)
Brass	6–13		773 278	6)
Material	IP protection	Dust labelling	Gas labelling	
Plastic	IP66	II 2D Extb IIIC Db	II 2G Exe IIC Gb	
Brass				

5) PTB 13 ATEX 1015 X; IECEx PTB 13.00034 X

6) PTB 04 ATEX 1112 X; IECEx PTB 13.00027 X

8.2 External earth connection for terminal box

Connection terminals are provided for external earth connection on solenoids with terminal boxes.

If it is not possible to connect the potential equalisation via pipeline or the use of a plastic valve, there is the possibility of establishing the connection via the external earth connection. The use is therefore optional and is the responsibility of the operator.

The connection capacity of the ring terminal is 4–6 mm². The connection is established as shown in “Fig. 6”.

9 INSTALLATION AND DISASSEMBLY



DANGER!

Risk of injury due to high pressure in the system or device.

- ▶ Before working on the system or device, switch off the pressure and ventilate or empty the lines.

Risk of injury due to electric shock.

- ▶ Before working on the system or device, switch off the power supply and secure against reactivation.
- ▶ Observe the applicable accident prevention and safety regulations for electrical devices.

Risk of burns or fire from hot device surfaces due to prolonged operation.

- ▶ Keep the device away from highly flammable substances and media and do not touch with bare hands.

Danger of short circuit due to damaged connection cables.

- ▶ Coil connection cables must be attached firmly and protected from damage.

Risk of explosion.

Solenoids and valve bodies form a closed system after installation. When used in an Ex area, there is a risk of explosion when the system is opened in the operating state.

- ▶ Do not dismantle or open the system during operation.



DANGER!

Risk of explosion due to electrostatic discharge.

If there is a sudden discharge of electrostatically charged devices or persons, there is a risk of explosion in the Ex area.

- ▶ Use suitable measures to ensure that electrostatic charges cannot occur in the Ex area.
- ▶ The device must not be used in areas with processes that generate heavy charges, involve automated grinding or cutting, the spraying of electrons (e.g. near electrostatic painting equipment), or generate pneumatically propelled dust.
- ▶ Clean the surface of the solenoid valve device by gently wiping it with a damp or anti-static cloth only.



WARNING!

Risk of injury due to improper installation.

- ▶ Installation may only be carried out by trained technicians with the appropriate tools.
- ▶ Secure the system against unintentional activation.
- ▶ Following installation, ensure a controlled restart.

9.1 Installing the valve



An exact description of the installation can be found in the operating instructions for the valve in question and/or online at: www.buerkert.de

9.2 Electrical connection



DANGER!

Risk of injury due to electric shock.

- ▶ Before reaching into the system, switch off the power supply and secure against reactivation.
- ▶ Observe the applicable accident prevention and safety regulations for electrical devices.

If there is no electrical contact between the metal valve components and the protective conductor of the coil, there is a risk of electric shock.

- ▶ Always connect protective conductor.
- ▶ Check electrical continuity between the protective conductor of the coil and the core guide tube of the valve.

With solenoids with terminal boxes, you must also ensure that you:

- ▶ Only insert permanent cables and lines.
- ▶ Use suitable cable and wiring guides (see chapter “8”). Pay attention to the provisions in the operating instructions included.
- ▶ In the terminal boxes, only connect wires with terminal connections measuring between 0.5 mm² and 2.5 mm².
- ▶ Tighten the terminal screws with 0.25 Nm.
- ▶ Lock housing lid properly. Tighten locking screw with 2 Nm.
- ▶ Check the consistency of the protective earth connection.
- ▶ Only open the housing lid when the power is off.

- ▶ The temperature resistance of the cable must be min. 15 K above the max. ambient temperature.
- ▶ Use cable end sleeves on flexible lines.
- ▶ The external earth connection terminals, supplied in a bag and glued into the housing lid, must be removed when installing the device.



9.2.1 Solenoids with cable outlet



The connection cable is cast with the Type AC19 solenoid and cannot be removed. Observe the voltage listed on the type label.

Wire colour	Pin assignment
Green-yellow	Protective conductor
Black	Phase/positive pole (+)
Black	Neutral conductor/negative pole (-)

9.2.2 Solenoids with terminal box

	Position	Pin assignment of the supply line
Black		Protective conductor
Black		Neutral conductor/negative pole (-)
Green-yellow		Phase/positive pole (+)

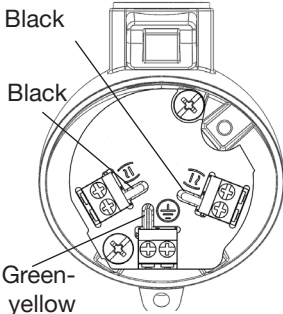

Fig. 5: Terminal box

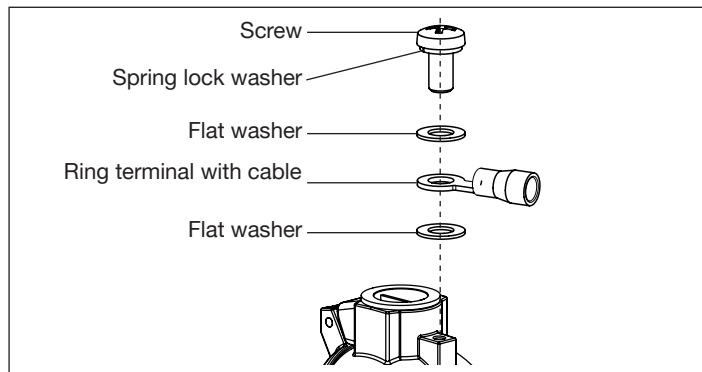

Fig. 6: Connection of external potential equalisation

9.3 Disassembly



DANGER!

Risk of injury due to high pressure in the system or device.

- ▶ Before working on the system or device, switch off the pressure and ventilate/empty the lines.

Risk of injury due to electric shock.

- ▶ Before working on the system or device, switch off the power supply and secure it against reactivation.
- ▶ Observe the applicable accident prevention and safety regulations for electrical devices.



WARNING!

Risk of injury due to improper disassembly.

- ▶ Disassembly must be performed only by trained personnel using suitable tools.

Risk of injury due to medium leaking out of leaky connections.

- ▶ Carefully seal connection lines.

→ Disconnect electrical connection.

→ Disconnect valve body from the pipeline.

NOTE!

Malfunctions due to contamination!

- For new installations, remove old PTFE tape from the connections. Tape residue must not get into the pipeline.

10 START-UP



WARNING!

Risk of injury due to improper operation.

Improper operation may result in injuries as well as damage to the device and the area around it.

- ▶ Before start-up, ensure that the operating personnel are aware of and have completely understood the contents of the operating instructions.
- ▶ The safety instructions must be followed and the device used only as intended.
- ▶ Only adequately trained personnel may start up the system or device.

Before start-up, ensure that

- the device has been installed correctly,
- the connection has been properly executed,
- the device is not damaged,
- all screws have been tightened.

11 MAINTENANCE, REPAIRS, TROUBLESHOOTING

11.1 Maintenance

The AC19 solenoid is maintenance-free if the operating conditions described in the instructions are observed.

11.2 Repair



DANGER!

Risk of injury due to improper repair.

The safety and function of the AC19 solenoid and the accompanying solenoid valve are only ensured after a repair if the repairs were done by the manufacturer.

- ▶ Only have the device repaired by the manufacturer.

11.3 Troubleshooting

In the case of malfunction, ensure that

- the device has been installed correctly,
- the connection has been properly executed,
- the device is not damaged,
- voltage and pressure have been applied,
- the pipelines are free,
- all screws have been tightened.

12 TRANSPORT, STORAGE, PACKAGING

NOTE!

Transport damage.

Inadequately protected devices may be damaged during transport.

- Protect the device against moisture and dirt in shock-resistant packaging during transport.
- Avoid exceeding or dropping below the permitted storage temperature.

Incorrect storage may damage the device.

- Store the device in a dry and dust-free location.
- Storage temperature: -40 °C ... $+80\text{ °C}$.

Damage to the environment caused by device parts contaminated with media.

- Dispose of the device and packaging in an environmentally friendly manner.
- Observe applicable disposal and environmental regulations.

www.burkert.com