

PTB 14 ATEX 2023 X, EPS 16 ATEX 1046 X

Solenoid coil Type AC10

Magnetspule Typ AC10

Bobine magnétique Type AC10

Device with II 2G/D Ex approval

Geräte mit II 2G/D Ex Zulassung

Appareils avec mode de protection II 2G/D Ex

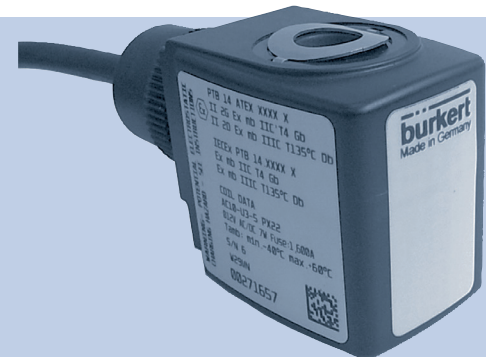

Operating Instructions

Bedienungsanleitung

Manuel d'utilisation



We reserve the right to make technical changes without notice.
Technische Änderungen vorbehalten.
Sous réserve de modifications techniques.

© Bürkert Werke GmbH & Co. KG, 2011 - 2017

Operating Instructions 1706/0G_ÖWEÖP_00810Í G / Original DE



1 OPERATING INSTRUCTION	4	7.6	Electrical data for solenoid coils with terminal box.....	15
1.1 Definition of terms	4	7.7	Electrical data for solenoid coils with terminal box and integrated equipment protection fuse.....	16
1.2 Symbols.....	4	8 ACCESSORIES	17	
2 AUTHORISED USE	5	8.1	Cable gland for terminal box.....	17
2.1 Explosion protection approval.....	5	8.2	External grounding connection for terminal box.....	17
3 BASIC SAFETY INSTRUCTIONS	6	8.3	Equipment protection fuse Type 1058.....	17
4 GENERAL INFORMATION	7	9 INSTALLATION AND REMOVAL	18	
4.1 Contact addresses	7	9.1	Installation	19
4.2 Warranty	7	9.2	Electrical connection	19
4.3 Information on the internet	7	9.3	Removal.....	21
5 PRODUCT DESCRIPTION	8	10 START-UP	21	
5.1 Design.....	8	11 MAINTENANCE, REPAIR, TROUBLESHOOTING	22	
5.2 Solenoid coil with cable outlet	9	11.1	Maintenance work.....	22
5.3 Solenoid coil with terminal box.....	9	11.2	Repair.....	22
6 APPLICATION CONDITIONS OF THE DEVICES	10	11.3	Troubleshooting	22
6.1 Special conditions.....	10	12 TRANSPORTATION, STORAGE, DISPOSAL	22	
6.2 Operating conditions.....	11			
6.3 Operating temperature range.....	11			
7 TECHNICAL DATA	11			
7.1 Safety instructions.....	11			
7.2 Conformity.....	11			
7.3 Standards.....	11			
7.4 Type label for explosions-risk areas	12			
7.5 Electrical data for solenoid coils with cable outlet	14			

1 OPERATING INSTRUCTION

The operating instructions describe the entire life cycle of the device. Keep these instructions in a location which is easily accessible to every user and make these instructions available to every new owner of the device.

Operating instruction contain important information.

- ▶ Read the operating instructions carefully and follow the safety instructions in particular.
- ▶ Operating instructions must be available to each user.
- ▶ The liability and warranty for the device are void if the operating instructions are not followed.

1.1 Definition of terms

In these instructions, the term “device” always refers to the solenoid coil AC10.

 In these instructions, the abbreviation “Ex” always refers to “potentially explosive”.

1.2 Symbols



DANGER!

Warns of an immediate danger.

- ▶ Failure to observe the warning may result in a fatal or serious injury.



WARNING!

Warns of a potentially dangerous situation.

- ▶ Failure to observe the warning may result in serious injuries or death.



CAUTION!

Warns of a possible danger.

- ▶ Failure to observe this warning may result in a moderate or minor injury.

NOTE!

Warns of damage to property.



Important tips and recommendations.



Refers to information in these operating instructions or in other documentation.

- ▶ designates an instruction to prevent risks.
- designates a procedure which you must carry out.

2 AUTHORIZED USE

Unauthorized use of the solenoid coil AC10 may be dangerous to people, nearby equipment and the environment.

The solenoid coil AC10 is used to activate valves which control the gaseous or liquid media.

- ▶ A valve controlled by the solenoid coil AC10 may be used solely for the media specified in the data sheet and for use in explosion group IIC category 2G and/or explosion group IIIC category 2G, and temperature class T4, T5 or T6 (refer to the specifications on the type label for explosion-risk areas).
- ▶ The solenoid coil may be used only for the applications designated in chapter [“6 Application conditions of the devices”](#) and in conjunction with third-party devices and components recommended and authorized by Bürkert.
- ▶ The applied protection class is encapsulation Ex “m” for coils with cable connection.
- ▶ The ignition protection type for the optionally mounted terminal box is “e” for gas and “t” for dust.
- ▶ The faultless and reliable operation of the system assumes correct transportation, correct storage and installation as well as careful operation and maintenance. Any other use is regarded as **unauthorized**. Bürkert is not liable for any resulting damage. The user alone bears the risk.
- ▶ Only use the device for its intended purpose.

2.1 Explosion protection approval

The explosion protection approval is only valid if you use the modules and components authorized by Bürkert, as described in these operating instructions.

The solenoid coil AC10 may be used only in combination with the valve types released by Bürkert, otherwise the explosion protection approval will be terminated. If you make unauthorized changes to the system, the modules or components, the explosion protection approval will also be void. EC-type examination certificate and IECEx certificate were issued by PTB (Physikalisch Technische Bundesanstalt) respectively Bureau Veritas

Solenoid coil AC10: PTB 14 ATEX 2023 X;
IECEx PTB 14.0049X

Terminal box: PTB 15 ATEX 1011 U;
IECEx PTB 15.0037U

Equipment protection fuse: PTB ATEX 2064 U;
IECEx PTB 16.0019U

Assembly of solenoid coil and terminal box and equipment protection fuse: EPS 16 ATEX 1046 X;
IECEx EPS 16.0021X

Manufacture is audited by: CE 102
PTB (Physikalisch Technische Bundesanstalt)
Bundesallee 100
38116 Braunschweig

The EU Type Examination Certificate is available online at:
www.burkert.com

3 BASIC SAFETY INSTRUCTIONS

These safety instructions do not consider any contingencies or incidents which occur during installation, operation and maintenance.

The operator is responsible for observing the location-specific safety regulations, also with reference to the personnel.



Danger – high pressure.

- ▶ Before loosening the lines and valves, turn off the pressure and vent the lines.

Risk of electric shock.

- ▶ Before reaching into the device, switch off the power supply and secure to prevent reactivation!
- ▶ Observe applicable accident prevention and safety regulations for electrical equipment!

Risk of burns and risk of fire if used during long-term operation through hot device surface.

The solenoid coil can get very hot during long-term operation.

- ▶ Keep the device away from highly flammable substances and media and do not touch the device with bare hands.



Risk of explosion.

The solenoid coil and valve body form a closed system after installation. When used in explosion-risk areas, there is a risk of explosion if the system is opened in the operating state.

- ▶ Do not remove or open the system during operation.

Risk of explosion due to electrostatic discharge.

In the event of a sudden discharge from electrostatically charged devices or individuals, there is a risk of an explosion in the explosion-risk area.

- ▶ Take suitable measures to ensure that no electrostatic discharges can build up in the explosion-risk area.
- ▶ Do not use the device in areas where there are powerful charge-generating processes, mechanical reaming and cutting processes, the spraying of electrons (e.g. in the vicinity of electrostatic coating equipment) as well as pneumatically conveyed dust.
- ▶ Clean the device surface by gently wiping it with a damp or anti-static cloth only.

To avoid the risk of explosion, the following must be observed for operation in explosion-risk areas:

- ▶ Information on the temperature class, ambient temperature, degree of protection and voltage on the type label for explosion-risk areas.
- ▶ Installation, operation and maintenance may only be performed by qualified specialists.
- ▶ The applicable safety regulations (including national regulations) as well as general technical standards must be observed during setup and operation.

- ▶ Repairs may only be performed by the manufacturer.
- ▶ The device must not be exposed to any mechanical and/or thermal loads which exceed the limits specified in the operating instructions.
- ▶ Before opening the terminal box, disconnect the power supply.

General hazardous situations.

To prevent injury, ensure:

- ▶ Secure system/equipment against unintentional activation.
- ▶ Observe the direction of flow during installation.
- ▶ After an interruption in the power supply or pneumatic supply, ensure that the process is restarted in a defined or controlled manner.
- ▶ Don't use the device as a lever when screwing the valve into the line.

4 GENERAL INFORMATION

4.1 Contact addresses

Germany

Bürkert Fluid Control Systems
Sales Center
Christian-Bürkert-Str. 13-17
D-74653 Ingelfingen
Tel. + 49 (0) 7940 - 10 91 111
Fax + 49 (0) 7940 - 10 91 448
E-mail: info@de.buerkert.com

International

Contact addresses can be found on the final pages of the printed operating instructions.

And also on the Internet at: www.burkert.com

4.2 Warranty

The warranty is only valid if the solenoid coil AC10 is used as intended in accordance with the specified application conditions.

4.3 Information on the internet

Operating instructions and data sheets for Bürkert products are available online at: www.burkert.com

5 PRODUCT DESCRIPTION

5.1 Design

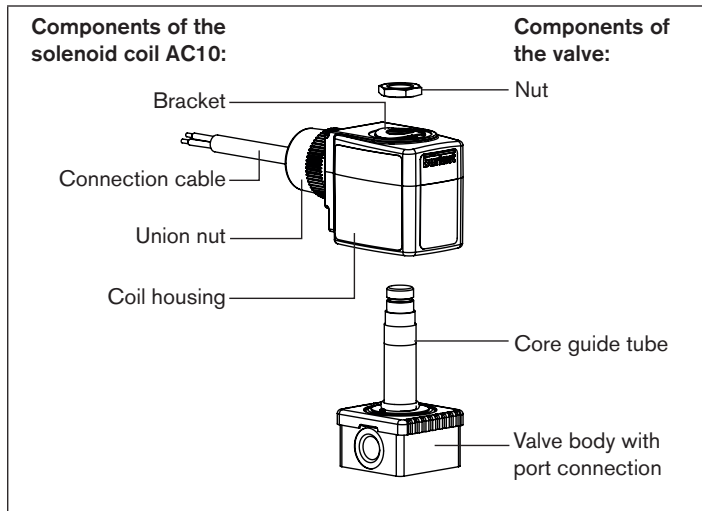

Fig. 1: Solenoid coil Type AC10 with cable outlet

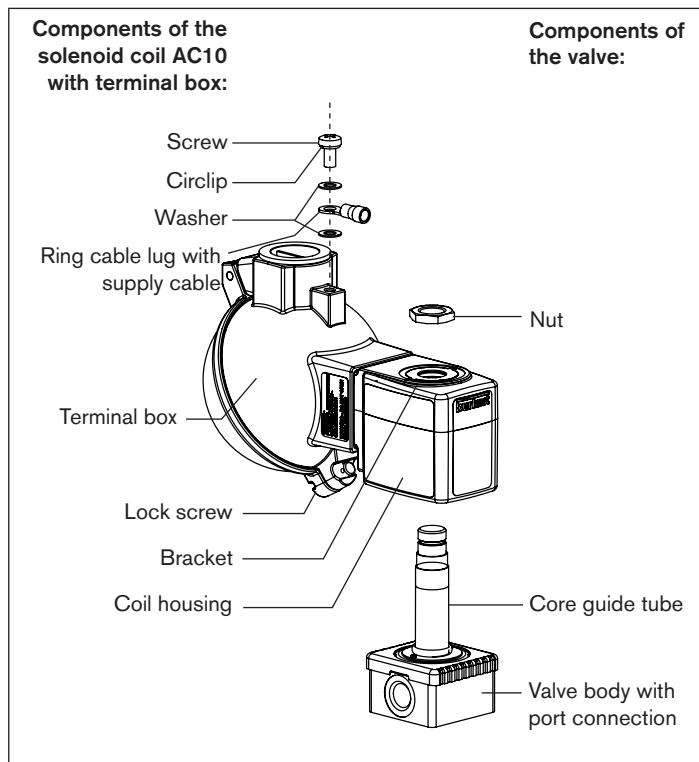

Fig. 2: Solenoid coil Type AC10 with terminal box

5.2 Solenoid coil with cable outlet

The solenoid coil type AC10 is an electromagnetic valve actuator for various Bürkert valves. As a so-called top-mounted coil, it is separated 100 % from the valve. The valve is a closed system even if the coil is removed.

The solenoid coil consists of:

- coil winding,
- coil housing (made from epoxy),
- electrical connection cable,
- bridge rectifier.

Alternating current or direct current control is possible.

The solenoid coil type AC10 is available in a range of ratings distributed across 2 frame sizes. The interface between the coil and valve is identical for both frame sizes.

The coil is placed over the core guide tube of the valve and attached with a nut. It is positively locked to prevent turning relative to the valve.

The electrical connection cable exits perpendicular to the coil axis. The cable is permanently integrated in the coil. The union nut is not designed to be removed.

An electrical contact is made between the metal components of the valve and the coil at the interface between the coil and the valve. All metal components must be grounded via the protective conductor in the connection cable.

5.3 Solenoid coil with terminal box

The design of the solenoid coil is identical to the description under [“5.2”](#), however a terminal box is also installed here (see [“Fig. 2”](#)). The terminal box is certified with the Type Examination Certificate PTB 15 ATEX 1011 U or IECEx PTB 15.0037U.

The cable outlet direction can be selected according to the order requirements. The outlet direction can be changed subsequently, however this requires a special tool¹⁾. Optionally a connection set is enclosed for additional potential equalization; to do this, observe the specifications in chapter [“8.2”](#).

Optionally a equipment protection fuse of Type 1058 can be integrated in the terminal box.

¹⁾ To do this, please contact your local Bürkert representative.

6 APPLICATION CONDITIONS OF THE DEVICES

6.1 Special conditions

6.1.1 Avoiding build-up of electrostatic charge



WARNING!

Risk of explosion due to electrostatic discharge.

In the event of a sudden discharge from electrostatically charged devices or individuals, there is a risk of an explosion in the explosion-risk area.

- ▶ Take suitable measures to ensure that no electrostatic discharges can build up in the explosion-risk area.
- ▶ Do not use the device in areas where there are powerful charge-generating processes, mechanical reaming and cutting processes, the spraying of electrons (e.g. in the vicinity of electrostatic coating equipment) as well as pneumatically conveyed dust.
- ▶ Clean the device surface by gently wiping it with a damp or anti-static cloth only.

6.1.2 Short-circuit protection

A fuse (max. 3 x Ib in accordance with IEC 60127-2-1) corresponding to the rated current must be connected ahead of every solenoid to protect against short circuits.

In the case of the version with a terminal box, there are devices which already have this fuse integrated.

- If the magnet has very low rated currents, the fuse with the lowest current value according to the stated IEC standard is adequate. This fuse must be connected separately upstream.
- The rated fuse voltage has to be the same as or higher than the specified nominal voltage of the solenoid. The rated fuse value is specified on the type label (see chapter "[7.4](#)").
- The interruption rating of the fuse link must be the same as or higher than the maximum short-circuit current to be accepted at the installation site (usually 1500 A).

6.1.3 Block assembly

Valve blocks are preferably made up so that all units have the same coil power consumption. If different coil power consumption values are used in a single valve block, then the technical data for the coil with the highest power rating must be used to determine the temperature class. In this case the ambient temperature must be no higher than +40 °C.

6.2 Operating conditions

The valve provides a cooling function for the solenoid coil. The solenoid coil may not be operated without a valve. The valve body must meet the following requirements:

- Material
Metal (brass, aluminium, stainless steel) or polyamide
- Minimum dimensions
32 mm x 32 mm x 10 mm

A larger valve body with a higher heat-dissipating capability can be used at any time.

The solenoid coils designed for individual installation may not be used for block assembly.

The solenoid coils designed for block assembly are suitable for both block assembly and for individual installation.

6.3 Operating temperature range

Observe the operating temperature range specified in the electrical data for all types.

7 TECHNICAL DATA

7.1 Safety instructions



DANGER!

Risk of explosion.

Dangerous situations can result if the technical safety data and values specified on the type label aren't observed or cannot be met.

- ▶ The degree of protection and temperature class for use of the device must be observed.

Exceeding the voltage specified on the type label creates a safety hazard since it can lead to overheating of the device!

- ▶ Don't connect the device to a higher voltage than that specified on the type label.

7.2 Conformity

The solenoid coil Type AC10 is compliant with the EU Directives according to the EU Declaration of Conformity (if applicable).

7.3 Standards

The applied standards which are used to demonstrate compliance with the EU Directives are listed in the EU type test certificate and/or the EU Declaration of Conformity (if applicable).

7.4 Type label for explosions-risk areas

7.4.1 Identification of the solenoid coil

Solenoid coil AC10 with sample valve and the positions of the type label:

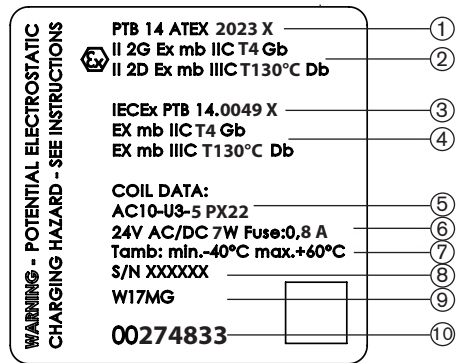
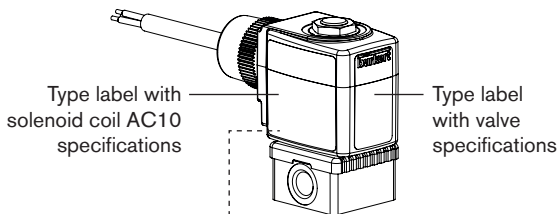

Legend:

Position	Description
1	ATEX, Certificate issuer and certificate number
2	ATEX, Explosion protection labelling
3	IECEX, Certificate issuer and certificate number
4	IECEX, Explosion protection labelling
5	Type label with Ex-code (last 4 digits)
6	Nominal voltage, nominal power, nominal fuse value
7	Ambient temperature range
8	Serial number
9	Date of manufacture
10	Identification number

Fig. 3: Location and description of the explosion type label

7.4.2 Identification of the terminal box

NOTE!

Attachment of the terminal box changes the ignition protection type.

Solenoid coil AC10 with terminal box with sample valve and the positions of the type label:

WARNING - POTENTIAL ELECTROSTATIC CHARGING HAZARD - SEE INSTRUCTION
WARNING - DO NOT OPEN WHEN ENERGIZED

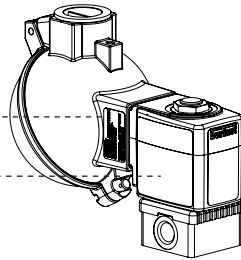

WARNING - POTENTIAL ELECTROSTATIC CHARGING HAZARD - SEE INSTRUCTIONS

EPS 16 ATEX 1046 X ①
 II 2G Ex eb mb IIC T4 Gb ②
 II 2D Ex mb tb IIIC T130°C Db

IECEX EPS 16.0021 X ③
 EX eb mb IIC T4 Gb ④
 EX mb tb IIIC T130°C Db

COIL DATA:
 AC10-U3-5 PX22 JA12 ⑤
 24V AC/DC 7W Fuse:0,8 A ⑥
 Tamb: min.-40°C max.+60°C ⑦
 S/N XXXXXX ⑧
 W17MG ⑨

00286863 ⑩

Legend:

Position	Description
1	ATEX, Certificate issuer and certificate number
2	ATEX, Explosion protection labelling
3	IECEX, Certificate issuer and certificate number
4	IECEX, Explosion protection labelling
5	Type label with Ex-code (last 4 digits)
6	Nominal voltage, nominal power, nominal fuse value
7	Ambient temperature range
8	Serial number
9	Date of manufacture
10	Identification number

Fig. 4: Location and description of the explosion type labels

7.5 Electrical data for solenoid coils with cable outlet

7.5.1 Coils for individual installation

Universal current, available nominal voltages from 12 V to 240 V, frequency 0 to 60 Hz

Code	Overall width in mm	Temperature class	Ambient temperature range in °C	Nominal power in W
PX22	32	T4	-40...+60	7.0
PX23	40	T4	-40...+60	9.0
PX25	32	T6	-40...+40	3.0
PX26	40	T6	-40...+60	1.8
PX27	32	T6	-40...+50	2.25
PX29	32	T5	-40...+60	3.0
PX31	32	T4	-40...+80	3.0

7.5.2 Coils for block assembly



DANGER!

Risk of explosion due to overheating!

- ▶ Don't connect the device to a higher voltage than that specified on the type label.

Universal current, available nominal voltages from 12 V to 240 V, frequency 0 to 60 Hz

Code	Overall width in mm	Temperature class	Ambient temperature range in °C	Nominal power in W
PX24	32	T4	-40...+40	7.0
PX28	32	T6	-40...+40	2.25
PX30	32	T5	-40...+50	3.0

7.5.3 Technical data of the connection cable

Material ²⁾ :	Electron beam cross-linked polyolefin copolymer
Operating temperature range ²⁾ :	-55...+145 °C for fixed installation
Minimum bending radius ²⁾ :	4 x outer diameter for fixed installation
Outside diameter ²⁾ :	6.2 mm
Design / function:	3 x stranded copper wire 0.75 mm ² / LNPE

Halogen free in accordance with IEC 60754-1

Tested according to DIN EN 13617-1 for use in gasoline pumps

²⁾ Specifications as per the manufacturer

Wire assignment:

Wire color	Assignment
green-yellow	Protective conductor
brown	Coil connection 1
blue	Coil connection 2

7.6 Electrical data for solenoid coils with terminal box

7.6.1 Coils for individual installation

Universal current, available nominal voltages from 12 V to 240 V, frequency 0 to 60 Hz

Code	Overall width in mm	Temperature class	Ambient temperature range in °C	Nominal power in W
PX22+JA12	32	T4	-40...+60	7.0
PX23+JA12	40	T4	-40...+60	9.0
PX25+JA12	32	T6	-40...+40	3.0
PX26+JA12	40	T6	-40...+60	1.8
PX27+JA12	32	T6	-40...+50	2.25
PX29+JA12	32	T5	-40...+60	3.0
PX31+JA12	32	T4	-40...+60	3.0

7.6.2 Coils for block assembly

Universal current, available nominal voltages from 12 V to 240 V, frequency 0 to 60 Hz

Code	Overall width in mm	Temperature class	Ambient temperature range in °C	Nominal power in W
PX24+JA12	32	T4	-40...+40	7,0
PX28+JA12	32	T6	-40...+40	2,25
PX30+JA12	32	T5	-40...+50	3,0

7.7 Electrical data for solenoid coils with terminal box and integrated equipment protection fuse

7.7.1 Coils for individual installation

Universal current, available nominal voltages from 12 V to 240 V, frequency 0 to 60 Hz

Code	Overall width in mm	Temperature class	Ambient temperature range in °C	Nominal power in W
PX22 + JA11	32	T4	-40...+60	7,0
PX23 + JA11	40	T4	-40...+60	9,0
PX25+ JA11	32	T6	-40...+40	3,0
PX26+ JA11	40	T6	-40...+60	1,8
PX27+ JA11	32	T6	-40...+50	2,25

7.7.2 Coils for block assembly

Universal current, available nominal voltages from 12 V to 240 V, frequency 0 to 60 Hz

Code	Overall width in mm	Temperature class	Ambient temperature range in °C	Nominal power in W
PX24+JA11	32	T4	-40...+40	7,0
PX28+JA11	32	T6	-40...+40	2,25

8 ACCESSORIES

8.1 Cable gland for terminal box

Suitable cable glands are available for use of the terminal box.



Cable glands from other manufacturers may also be used if they are designed for the installation location and can be installed correctly. Note that the application temperature of the cable gland must be min. 15 K above the max. ambient temperature.

Material	Clamping range [mm]	Operating temperature	Order number	Certificate number
Plastic	7...13	-40...+75 °C	773 277	3)
Brass	6...13		773 278	4)
Material	IP-Protection	Dust identification	Gas identification	
Plastic	IP66	II 2D Extb IIIC Db	II 2G Exe IIC Gb	
Brass				

3) PTB 13 ATEX 1015X; IECEX PTB 13.00034X

4) PTB 04 ATEX 1112X; IECEX PTB 13.00027X

8.2 External grounding connection for terminal box

If solenoid coils feature a terminal box, connection terminals are enclosed for the external grounding connection.

If the potential equalization is not to be connected by a pipeline or by the use of a plastic fitting, the connection can be made via the external grounding connection. Its use is therefore optional and must be assessed by the operator.

The connection capacity of the ring cable lug is 4-6 mm². The connection is made as shown in [“Fig. 8”](#).

8.3 Equipment protection fuse Type 1058

These replacement fuses are available for solenoid coils with terminal box and integrated equipment protection fuse.

Nominal fuse value	Nominal fuse value
0.050 A	300254
0.063 A	300255
0.080 A	300256
0.100 A	300257
0.125 A	300258
0.160 A	300259
0.200 A	300260

Nominal fuse value	Nominal fuse value
0.250 A	300261
0.315 A	300262
0.400 A	300263
0.500 A	300264
1.000 A	300265
1.250 A	300266
1.600 A	300267

When selecting the nominal fuse value, observe the specifications on the type label of the solenoid coil.

The following table shows an overview of the assignment of the nominal fuse values to the versions of the solenoid coil.

U_{Nom} (V) ⁵⁾	Nominal fuse value in A				
	PX22 / PX24 + JA11	PX23+ JA11	PX25+ JA11	PX26+ JA11	PX27 / PX28 + JA11
12	1.250	1.600	0.500	0.315	0.500
24	0.500	1.000	0.200	0.160	0.250
26	0.500	1.000	0.200	0.200	0.250
48	0.315	0.400	0.125	0.063	0.125
60	0.315	0.315	0.080	0.063	0.100
100	0.125	0.160	0.050	0.050	0.063
110	0.125	0.160	0.050	0.050	0.050
115	0.125	0.160	0.050	0.050	0.050
120	0.100	0.160	0.050	0.050	0.050
125	0.100	0.080	0.050	0.050	0.050
200	0.063	0.080	0.050	0.050	0.050
230	0.063	0.063	0.050	0.050	0.050

Tab. 1: assignment table of the nominal fuse values

⁵⁾ U_{Nom} : nominal voltage of the solenoid coil AC10

9 INSTALLATION AND REMOVAL



DANGER!

Danger – high pressure.

- ▶ Before loosening the lines and valves, turn off the pressure and vent the lines.

Risk of electric shock.

- ▶ Before reaching into the device, switch off the power supply and secure to prevent reactivation!
- ▶ Observe applicable accident prevention and safety regulations for electrical equipment!

Risk of burns or risk of fire if used during long-term operation through hot device surface.

- ▶ Keep the device away from highly flammable substances and media and do not touch the device with bare hands.

Risk of short-circuit due to damaged connection cable.

- ▶ The coil connection cable have to be fixed and protected against damage.

Risk of explosion.

The solenoid coil and valve body form a closed system after installation. When used in explosion-risk areas, there is a risk of explosion if the system is opened in the operating state.

- ▶ The system must not be disassembled during operation.



DANGER!

Risk of explosion due to electrostatic discharge.

In the event of a sudden discharge from electrostatically charged devices or individuals, there is a risk of an explosion in the explosion-risk area.

- ▶ Take suitable measures to ensure that no electrostatic discharges can build up in the explosion-risk area.
- ▶ Do not use the device in areas where there are powerful charge-generating processes, mechanical reaming and cutting processes, the spraying of electrons (e.g. in the vicinity of electrostatic coating equipment) as well as pneumatically conveyed dust.
- ▶ Clean the device surface by gently wiping it with a damp or anti-static cloth only.



WARNING!

Risk of injury from improper installation.

- ▶ Installation may be carried out by authorized technicians only and with the appropriate tools.
- ▶ Secure system from unintentional activation.
- ▶ Following assembly, ensure a controlled restart.

9.1 Installation



Detailed installation instructions can be found in the operating instructions of the respective valve and/or online at: www.burkert.com

9.2 Electrical connection



DANGER!

Risk of electric shock.

- ▶ Before reaching into the device, switch off the power supply and secure to prevent reactivation.
- ▶ Observe applicable accident prevention and safety regulations for electrical equipment.

There is a risk of electric shock if there is no electrical contact between the metal parts of the valve and the protective conductor of the coil.

- ▶ Always connect the protective conductor.
- ▶ Test for continuity between the protective conductor of the coil and the core guide tube of the valve.

If solenoid coils feature a terminal box, also observe the following:

- ▶ Insert permanently installed cables and lines only.
- ▶ Use a suitable cable and line entry (see chapter "8"). Observe specifications in the enclosed operating instructions.
- ▶ In the terminal box connect only wires which have a rated connection between 0.75 mm² and 1.5 mm².
- ▶ Tighten terminal screws to 1.2 Nm.
- ▶ Lock housing cover properly. Tighten lock screw to 2 Nm.
- ▶ Check continuity of the protective conductor connection.
- ▶ Before opening the housing cover, disconnect the power supply.
- ▶ Connect maximum two conductors to each terminal point.

- ▶ Temperature resistance of the cable must be min. 15 K above the max. ambient temperature.
- ▶ When using flexible lines, use wire end ferrules.

Terminal box:

- ▶ The connection terminals for the external earth connection, which are packed for delivery in a bag and bonded to the housing cover, must be removed during installation of the device.

9.2.1 Solenoid coils with cable outlet

! The connection cable is encapsulated with the solenoid coil Type AC10 and cannot be removed. Observe the indicated voltage according to the type label.

9.2.2 Solenoid coils with terminal box

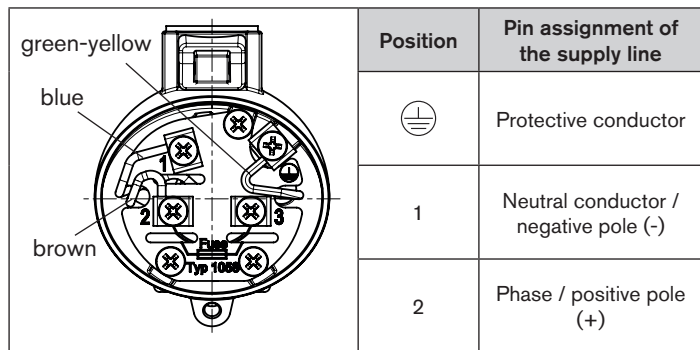

Fig. 5: Terminal box

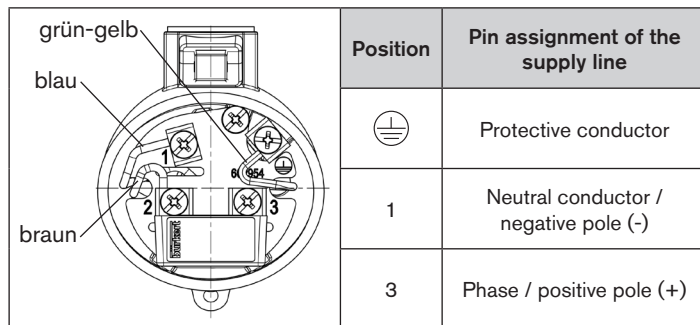

Fig. 6: Terminal box with integrated equipment protection fuse

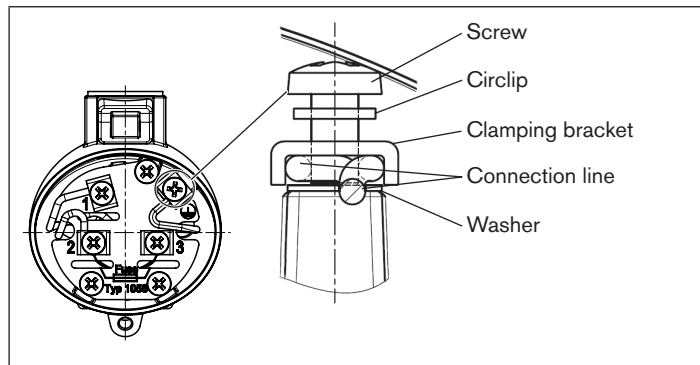

Fig. 7: Protective conductor connection

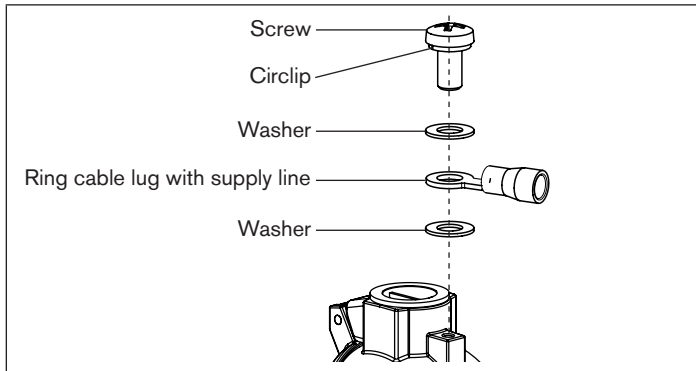

Fig. 8: Connection of external potential equalization

9.3 Removal

! DANGER!

Danger – high pressure.

- ▶ Before loosening the lines and valves, turn off the pressure and vent the lines.

Risk of electric shock.

- ▶ Before reaching into the device, switch off the power supply and secure to prevent reactivation!
- ▶ Observe applicable accident prevention and safety regulations for electrical equipment!

! WARNING!

Risk of injury from improper removal.

- ▶ Removal may be carried out by authorized technicians only and with the appropriate tools.

Risk of injury due to media escaping from leaky connections.

- ▶ Seal the connection lines carefully.

→ Separate the electrical connections.

→ Separate the valve body from the pipeline.

NOTE!

Malfunctions due to dirt!

- Remove the old PTFE tape from the connections during re-installs. Tape residue must not get into the pipeline.

10 START-UP

! WARNING!

Risk of injury from improper operation.

Improper operation may result in injuries as well as damage to the device and the area around it.

- ▶ Before start-up, ensure that the operating personnel are familiar with and completely understand the contents of the operating instructions.
- ▶ Observe the safety instructions and intended use.
- ▶ Only adequately trained personnel may start up the equipment or the device.

Before starting up the device, ensure that:

- the device has been installed correctly,
- the connection has been made properly,
- the device is not damaged.

11 MAINTENANCE, REPAIR, TROUBLESHOOTING

11.1 Maintenance work

The solenoid coil AC10 are maintenance-free when operated under the conditions described in this manual.

11.2 Repair



DANGER!

Danger due to improper repairs.

The safety and functionality of the AC10 coil and corresponding solenoid valve following a repair are only given if the repair work was performed by the manufacturer.

- ▶ Only have the device repaired by the manufacturer.

11.3 Troubleshooting

If malfunctions occur, ensure that:

- the device has been installed correctly,
- the connection has been made properly,

- the device is not damaged,
- the voltage and pressure have been switched on,
- the pipelines are free.

12 TRANSPORTATION, STORAGE, DISPOSAL

NOTE!

Transport damages!

Inadequately protected equipment may be damaged during transport.

- During transportation protect the device against wet and dirt in shock-resistant packaging.
- Avoid exceeding or dropping below the allowable storage temperature.

Incorrect storage may damage the device.

- Store the device in a dry and dust-free location!
- Storage temperature: -40...+55 °C.

Damage to the environment caused by device components contaminated with media.

- Ensure the device and packaging are disposed of in an environmentally sound manner.
- Observe applicable regulations relating to refuse disposal and the environment.

www.burkert.com